

# Parts Catalog

## Mazda PROTEGE & PROTEGE 5

U.S.A. & Canada  
( '01 ▶ )

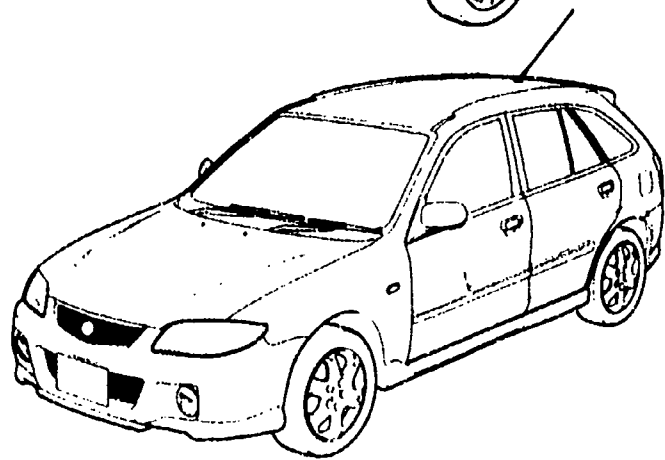
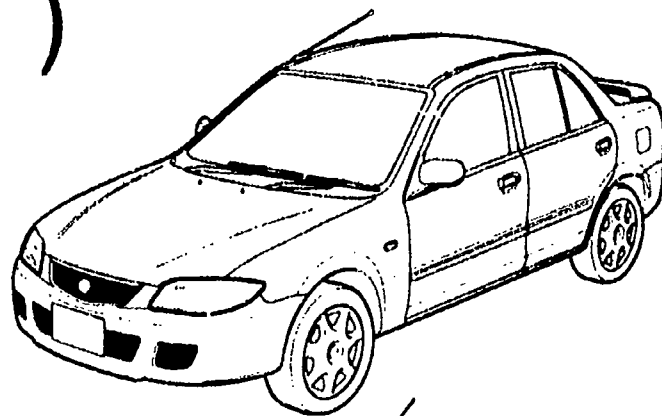

( BJ22\*-400001 - )

Jul. '01 (REVISED)

Catalog No. AU-BA09-02



**mazda**

© 2001 Mazda Motor Corporation

### LAYOUT OF CONTENTS / DISPOSITION TYPOGRAPHIQUE DE CONTENU / DISPOSICION DEL CONTENIDO / ANORDNUNG DES INHALTS



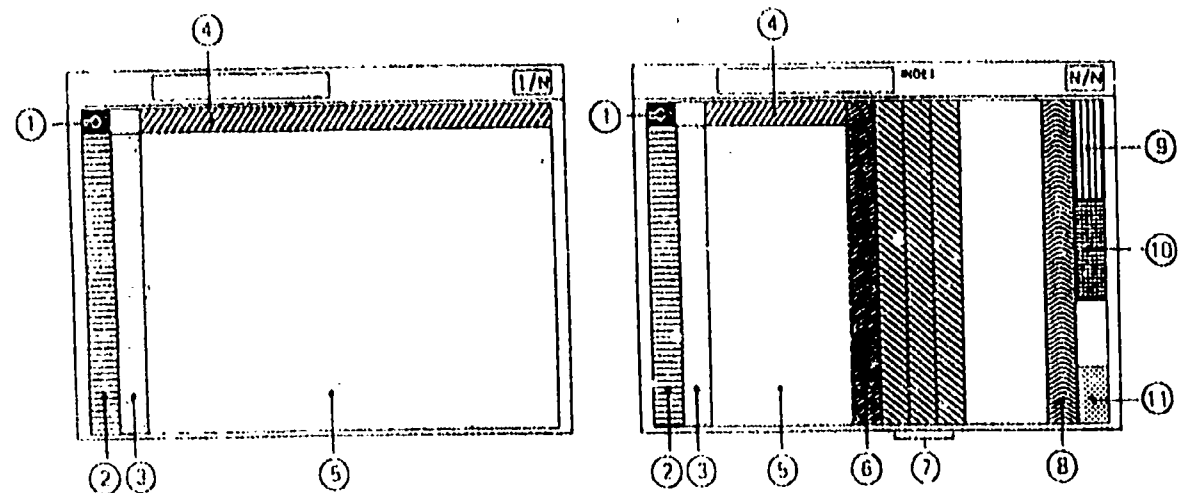







- The following is a typical example of the layout of contents on Mazda microfiche parts catalog.
- Voici un exemple typique de la disposition typographique de contenu dans les microfiches de catalogue des pièces de Mazda.
- El siguiente es un ejemplo típico de la disposición del contenido en una microficha del catálogo de repuestos de Mazda.
- Folgendes ist ein typisches Beispiel der Inhaltsanordnung des Mazda Mikrofiche-Teilekatalogs.

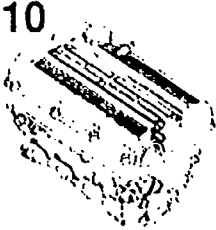
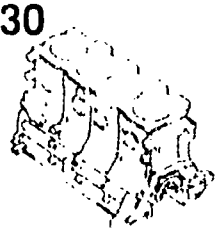
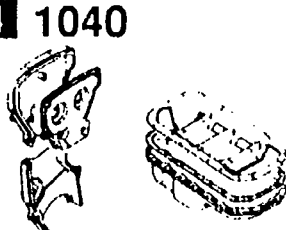
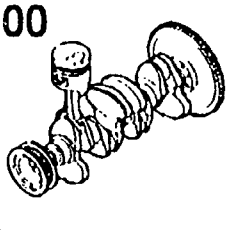
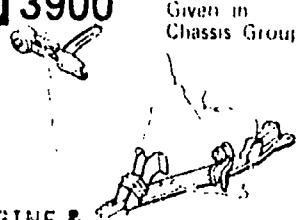

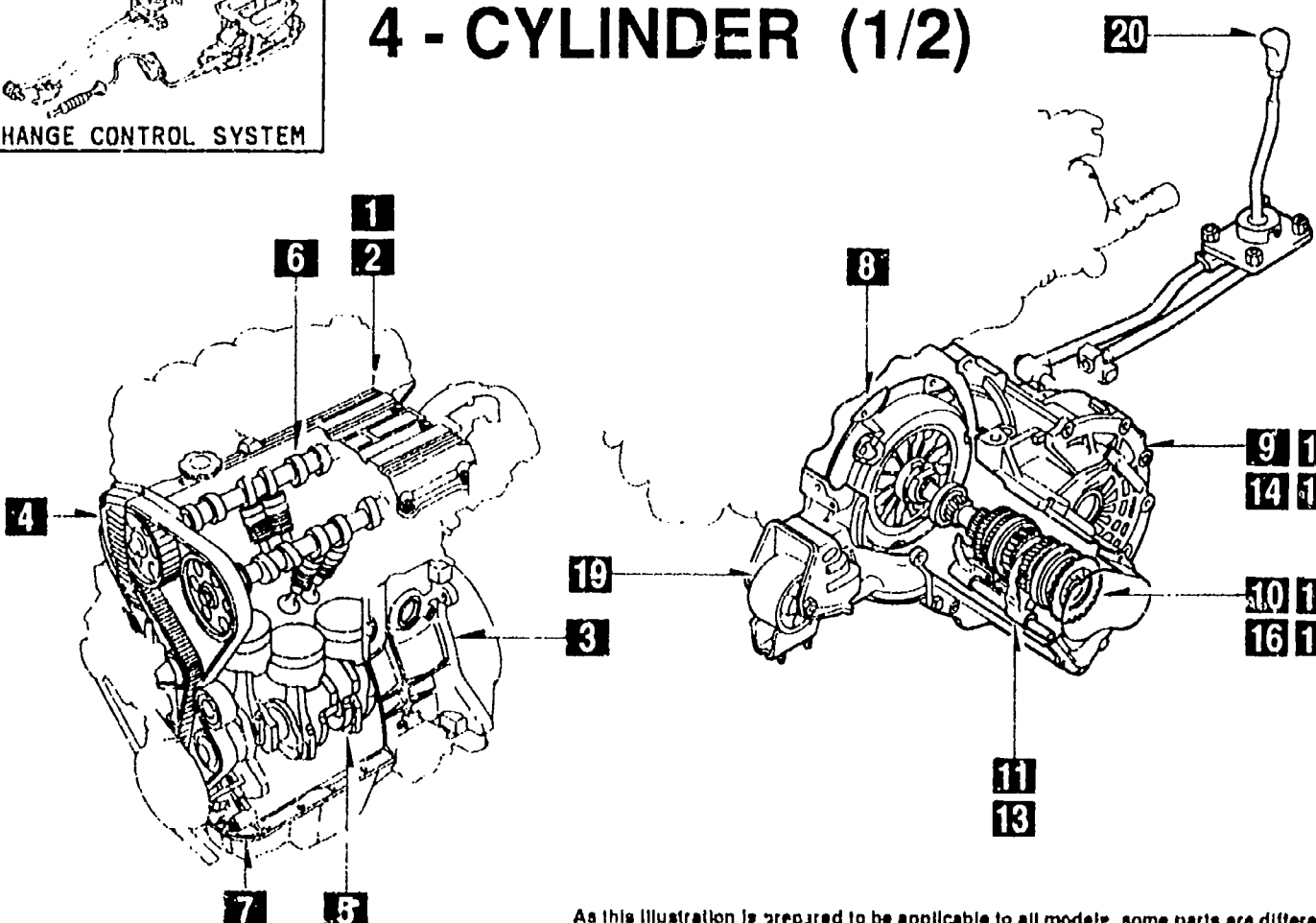
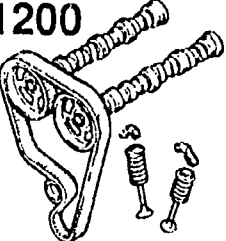
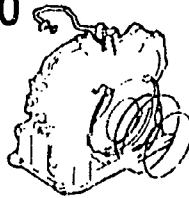
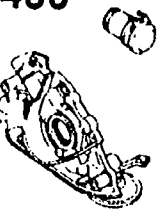

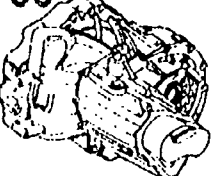
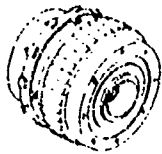

Remark : The items listed under ④ have been deleted from each fiche since Dec. '93

- |  |   |  |
|--|---|--|
| ① • Layout of contents<br>• Disposition Typographique de Contenu<br>• Disposición del contenido<br>• Anordnung des Inhalts   | ② • Pictorial Index<br>• Index par Schémas<br>• Índice Gráfico<br>• Illustrierter Index                           | ③ • Master Section No. Index<br>• Index des Numéros des Sections Totale<br>• Índice del Número de la Sección Maestra<br>• Hauptabschnittsnummer-Index      |
| <del>④ • Section No. Index for the Column<br/>• Index des Numéros des Sections pour les Colonnes<br/>• N° de la Sección para el Índice<br/>• Abschnittsnummer Index für die Spalte</del> | ⑤ • Illustration & Text<br>• Illustrations et Textes<br>• Ilustración y Texto<br>• Abbildung und Text             | ⑥ • Part No. Index<br>• Index des Numéros des Pièces<br>• Índice del N° de Pieza<br>• Teile-Nr. Index  |
| ⑦ • Alphabetical Index<br>• Index Alphabétique<br>• Índice Alfabético<br>• Alphabetischer Index  | ⑧ • Model Identification<br>• Identification des Modèles<br>• Identificación del Modelo<br>• Modell Kennzeichnung | ⑨ • Vehicle Identification System<br>• Système d'Identification de Véhicule<br>• Sistema de Identificación de Vehículo<br>• Fahrzeugidentifikations-system |



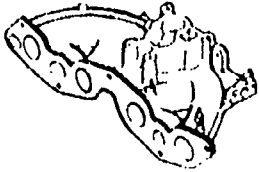
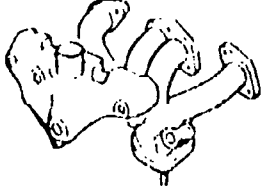
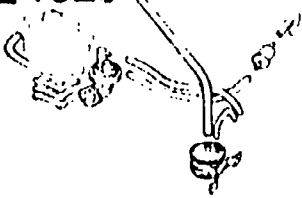
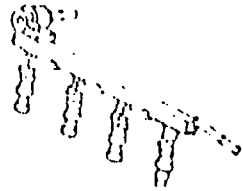
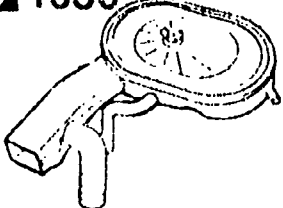

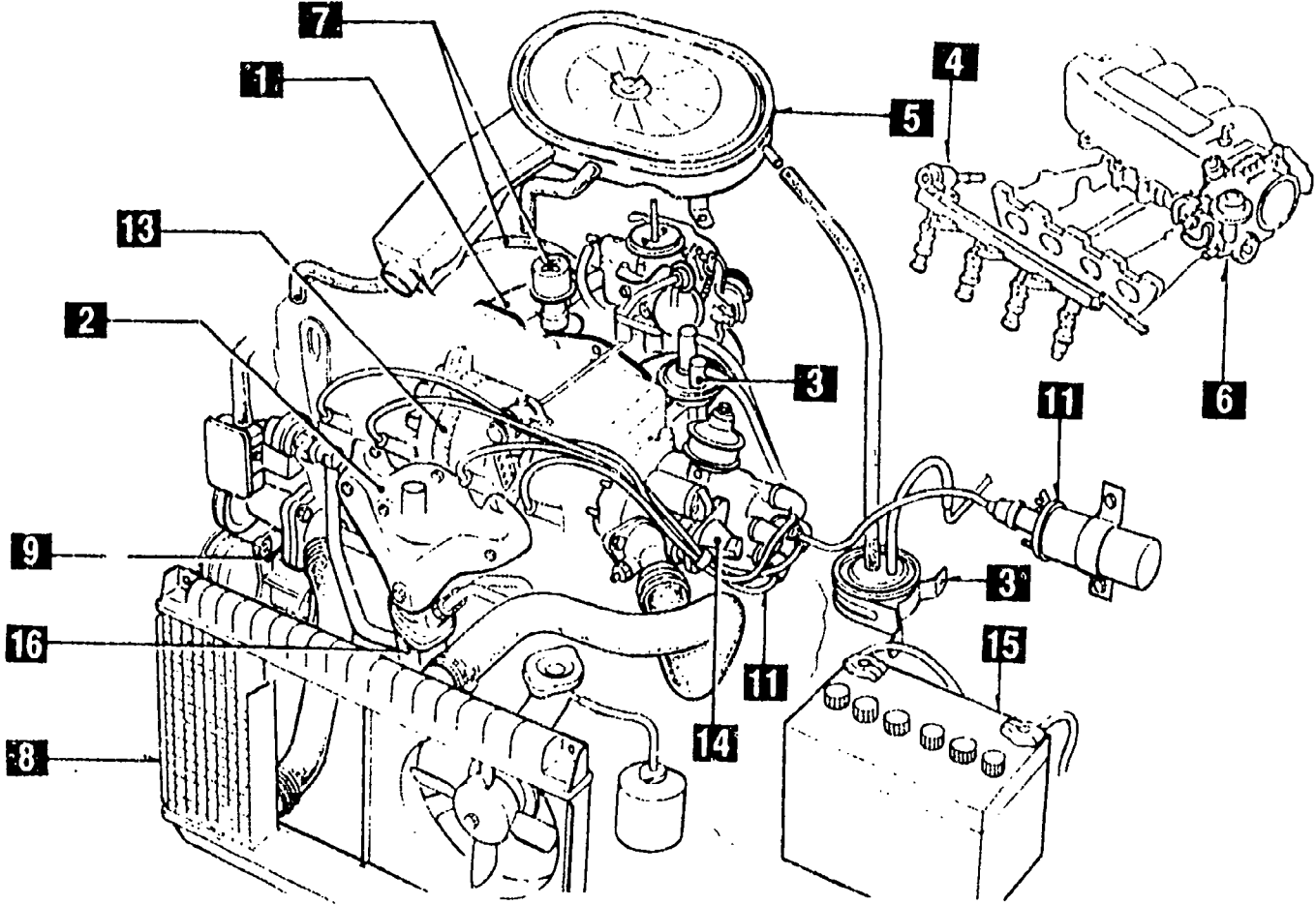

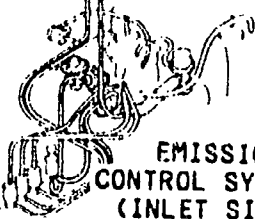
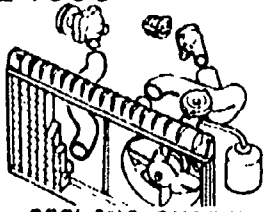
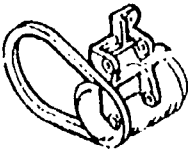
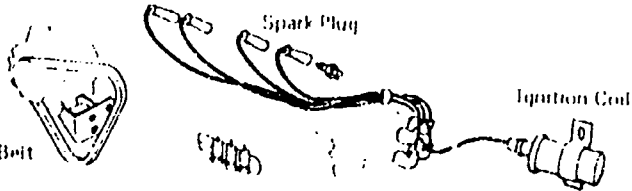
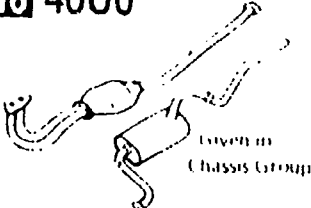
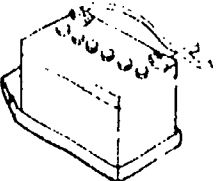
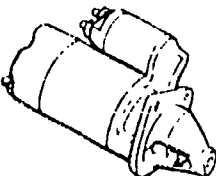
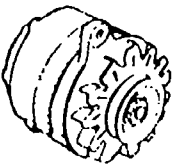
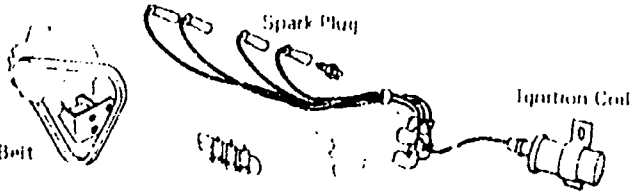
# PICTORIAL INDEX

<p><b>1000</b></p>  <p>SHORT &amp; PARTIAL ENGINE</p>	<p><b>1 1005</b></p>  <p>ENGINE GASKET SETS</p>	<p><b>2 1010</b></p>  <p>CYLINDER HEAD &amp; COVER</p>	<p><b>3 1030</b></p>  <p>CYLINDER BLOCK</p>	<p><b>4 1040</b></p>  <p>OIL PAN &amp; TIMING COVER</p>	<p><b>5 1100</b></p>  <p>PISTON, CRANKSHAFT &amp; FLYWHEEL</p>
<p><b>19 3900</b> Given in Chassis Group</p>  <p>ENGINE &amp; TRANSMISSION MOUNTINGS</p>	<p><b>20 4600</b> Given in Chassis Group</p>  <p>CHANGE CONTROL SYSTEM</p>	<h2 style="margin: 0;">GASOLINE ENGINE 4 - CYLINDER (1/2)</h2> 			<p><b>6 1200</b></p>  <p>VALVE SYSTEM</p>
<p><b>18 1960</b></p>  <p>GASKET &amp; SEAL KIT (AUTOMATIC)</p>	<p style="font-size: small;">As this illustration is prepared to be applicable to all models, some parts are different in specifications from parts listed in this parts Catalog.</p>			<p><b>7 1400</b></p>  <p>OIL PUMP &amp; FILTER</p>	
<p><b>17 1950</b></p>  <p>MANUAL LINKAGE SYSTEM (AUTOMATIC)</p>				<p><b>8 1600</b></p>  <p>CLUTCH DISC &amp; COVER (MANUAL)</p>	
<p><b>16 1940</b></p>  <p>GOVERNOR, LOW &amp; REVERSE PISTON (AUTOMATIC)</p>				<p><b>9 1700</b></p>  <p>TRANSMISSION CASE (MANUAL)</p>	
<p><b>15 1930</b></p>  <p>CLUTCHES &amp; PLANETARY GEARS (AUTOMATIC)</p>				<p><b>14 1925</b></p>  <p>CONTROL VALVE (AUTOMATIC)</p>	<p><b>13 1920</b></p>  <p>TRANSMISSION CASE &amp; MAIN CONTROL SYSTEM (AUTOMATIC)</p>

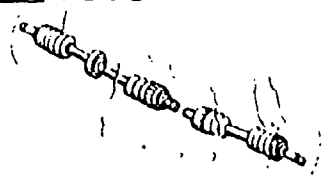
# PICTORIAL INDEX

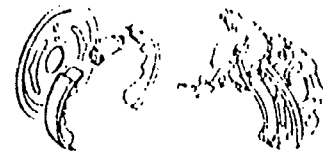
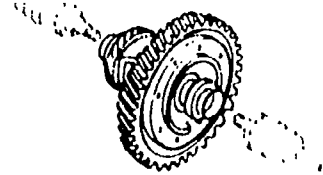
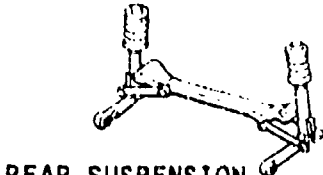
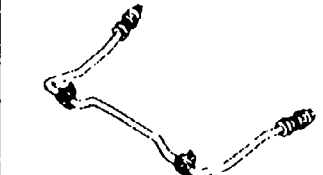
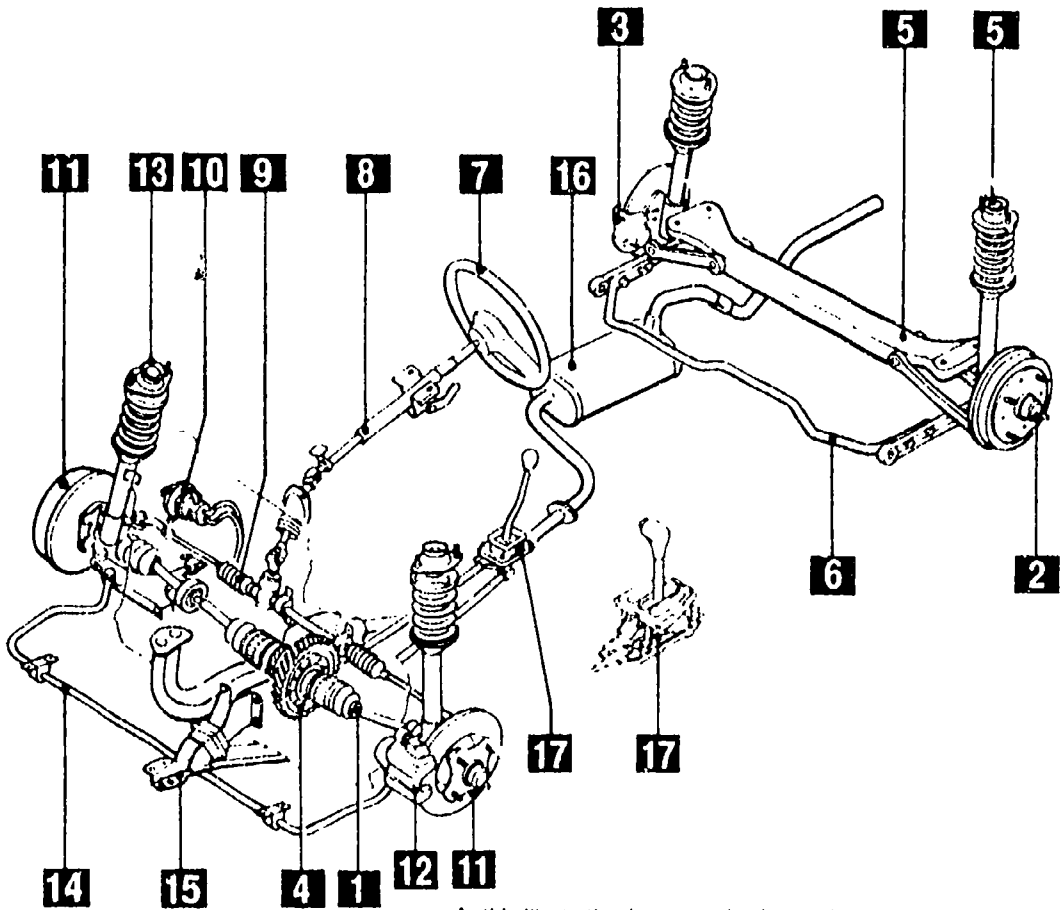
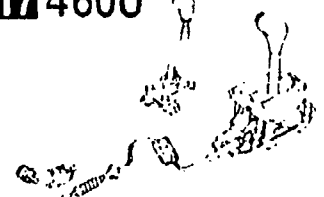

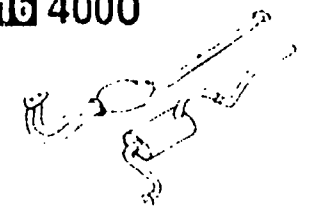
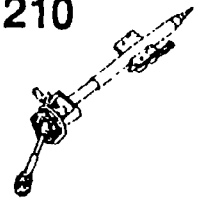
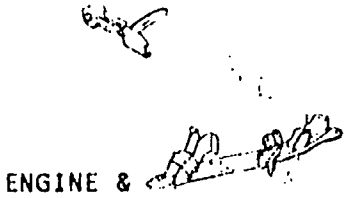
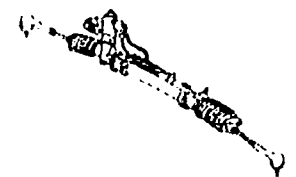
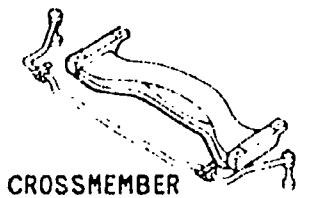
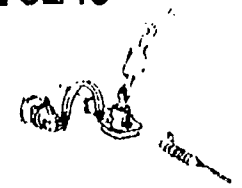
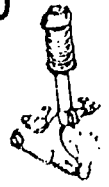
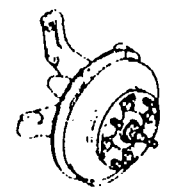

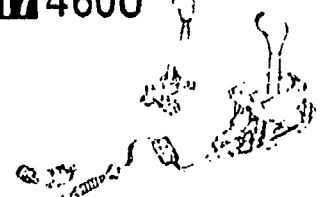

<b>1 1300</b>  INLET MANIFOLD	<b>2 1310</b>  EXHAUST MANIFOLD	<b>3 1320</b>  FUEL SYSTEM	<b>4 1325</b>  FUEL DISTRIBUTOR	<b>5 1330</b>  AIR CLEANER	<b>6 1364</b>  THROTTLE BODY
<h2 style="margin: 0;">GASOLINE ENGINE 4 - CYLINDER (2/2)</h2> 					
As this illustration is prepared to be applicable to all models, some parts are different in specifications from parts listed in this parts Catalog					
<b>6600</b> Given in BODY Group Control Unit    Regulator  SWITCHES & RELAYS (ENGINE)	<b>7 1370</b>  EMISSION CONTROL SYSTEM (INLET SIDE)	<b>8 1500</b>  COOLING SYSTEM	<b>9 1580</b>  BRACKET, PULLEY & BELT	<b>10</b>	<b>11 1800</b>  V Belt    Spark Plug    Ignition Coil ENGINE ELECTRICAL SYSTEM
<b>16 4000</b>  Given in Chassis Group EXHAUST SYSTEM	<b>15 1850</b>  BATTERY	<b>14 1840</b>  STARTER	<b>13 1830</b>  ALTERNATOR	<b>12</b>	<b>11 1800</b>  V Belt    Spark Plug    Ignition Coil ENGINE ELECTRICAL SYSTEM

# PICTORIAL INDEX

<p><b>1 2510</b></p>  <p>FRONT DRIVE SHAFTS</p>	<p><b>2 2600</b></p>  <p>REAR AXLE</p>	<p><b>3 2610</b></p>  <p>REAR BRAKE MECHANISMS</p>	<p><b>4 2700</b></p>  <p>FRONT DIFFERENTIALS</p>	<p><b>5 2800</b></p>  <p>REAR SUSPENSION MECHANISMS</p>	<p><b>6 2810</b></p>  <p>REAR STABILIZER</p>	
<h2 style="margin: 0;">CHASSIS (1/2)</h2>  <p style="font-size: small; text-align: center;">As this illustration is prepared to be applicable to all models, some parts are different in specifications from parts listed in this parts Catalog.</p>						
<p><b>17 4600</b></p>  <p>CHANGE CONTROL SYSTEM</p>						<p><b>7 3200</b></p>  <p>STEERING WHEEL</p>
<p><b>16 4000</b></p>  <p>EXHAUST SYSTEM</p>						<p><b>8 3210</b></p>  <p>STEERING COLUMN &amp; SHAFTS</p>
<p><b>15 3900</b></p>  <p>ENGINE &amp; T/MISSION MOUNTINGS</p>						<p><b>9 3220</b></p>  <p>STEERING GEAR</p>
<p><b>14 3410</b></p>  <p>CROSSMEMBER &amp; STABILIZER</p>						<p><b>10 3240</b></p>  <p>POWER STEERING SYSTEM</p>
<p><b>13 3400</b></p>  <p>FRONT SUSPENSION MECHANISMS</p>						<p><b>11 3300</b></p>  <p>FRONT AXLE</p>
<p><b>12 3310</b></p>  <p>FRONT BRAKE MECHANISMS</p>						<p><b>17 4600</b></p>  <p>CHANGE CONTROL SYSTEM</p>

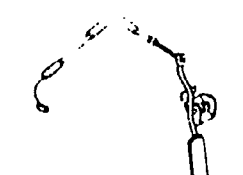
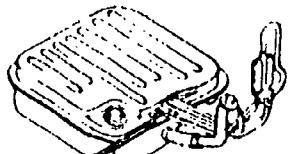
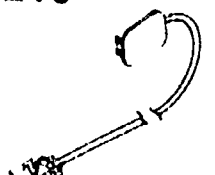
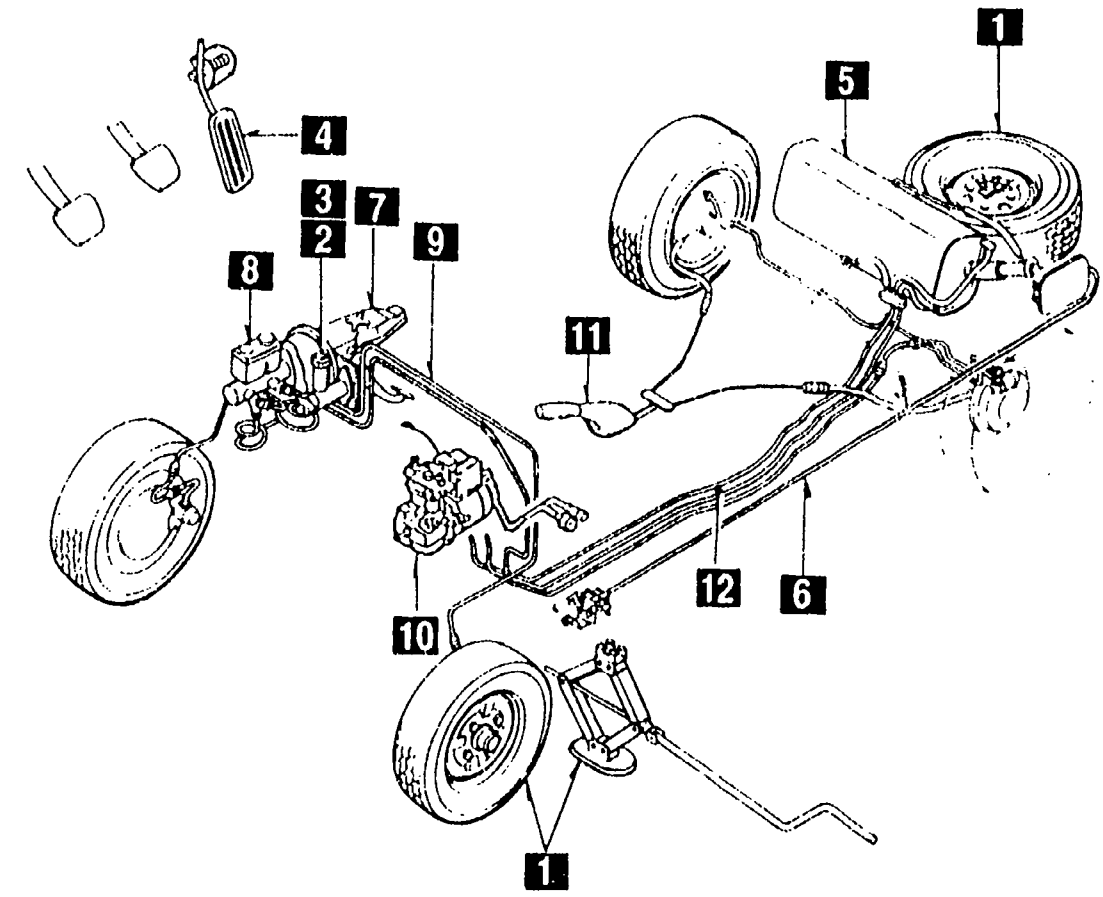

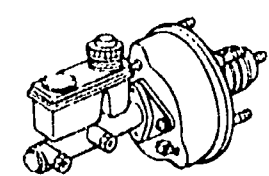

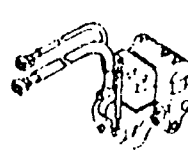
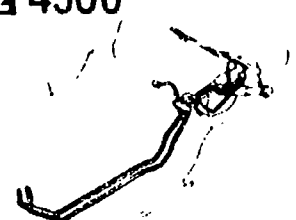
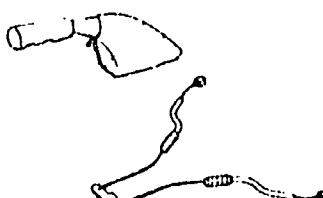



# PICTORIAL INDEX

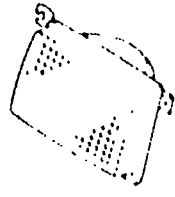
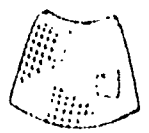
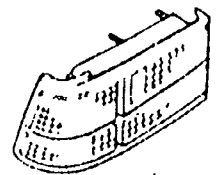

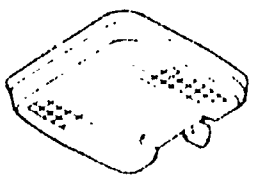
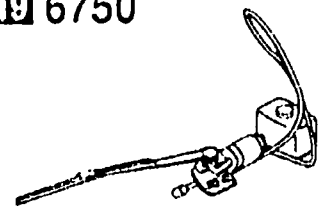
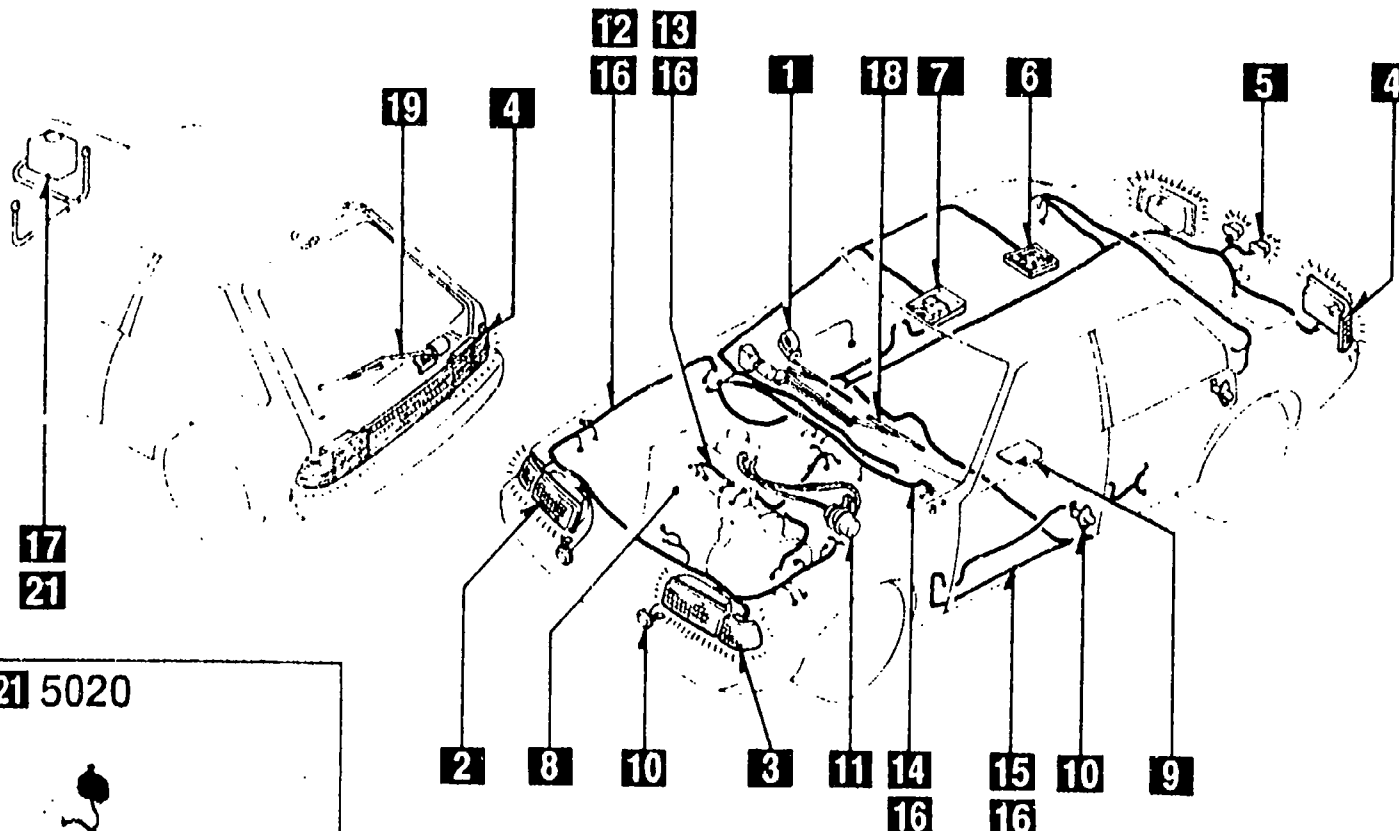
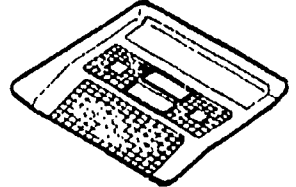
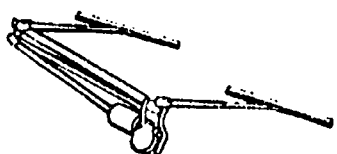
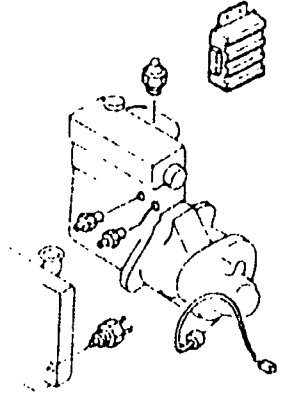
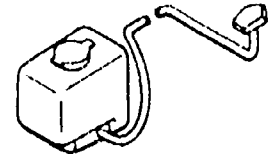



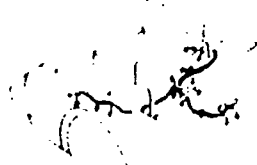
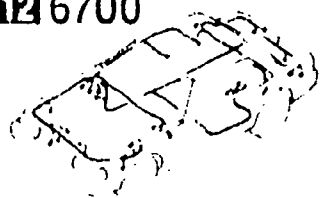
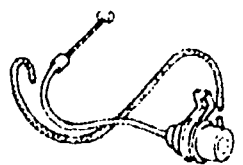
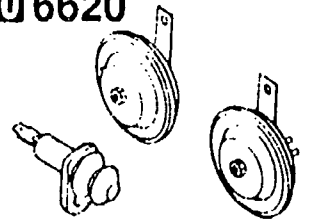
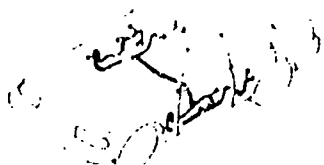

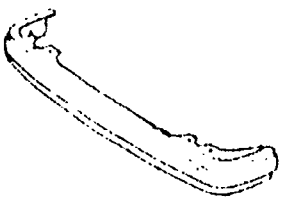
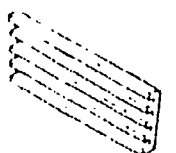
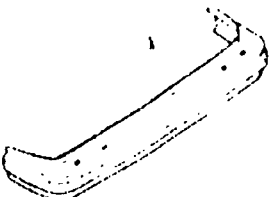

<b>1 3700</b>  TIRES & JACK	<b>2 4140</b>  CLUTCH RELEASE & MASTER CYLINDERS	<b>3 4145</b>  CLUTCH PIPINGS	<b>4 4160</b>  ACCELERATOR CONTROL SYSTEM	<b>5 4200</b>  FUEL TANK	<b>6 4210</b>  FUEL LID OPENER
<h2 style="margin: 0;">CHASSIS (2/2)</h2> 					
					<b>7 4300</b>  CLUTCH & BRAKE PEDALS
					<b>8 4340</b>  BRAKE MASTER CYLINDER & POWER BRAKE
					<b>9 4360</b>  BRAKE PIPINGS
					<b>10 4370</b>  ANTILOCK BRAKE SYSTEM
				<b>12 4500</b>  FUEL PIPINGS	<b>11 4400</b>  PARKING BRAKE SYSTEM

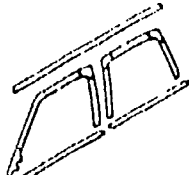
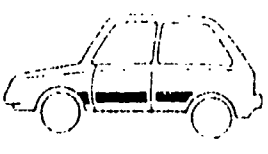
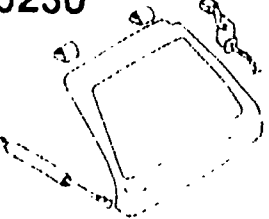
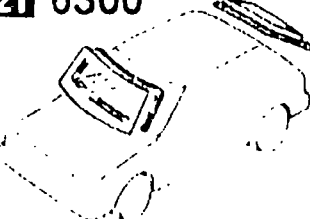
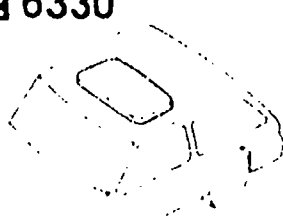
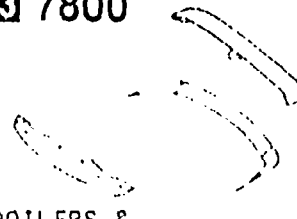
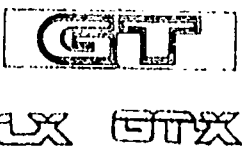
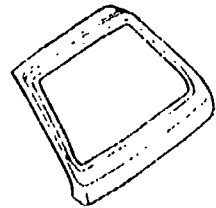
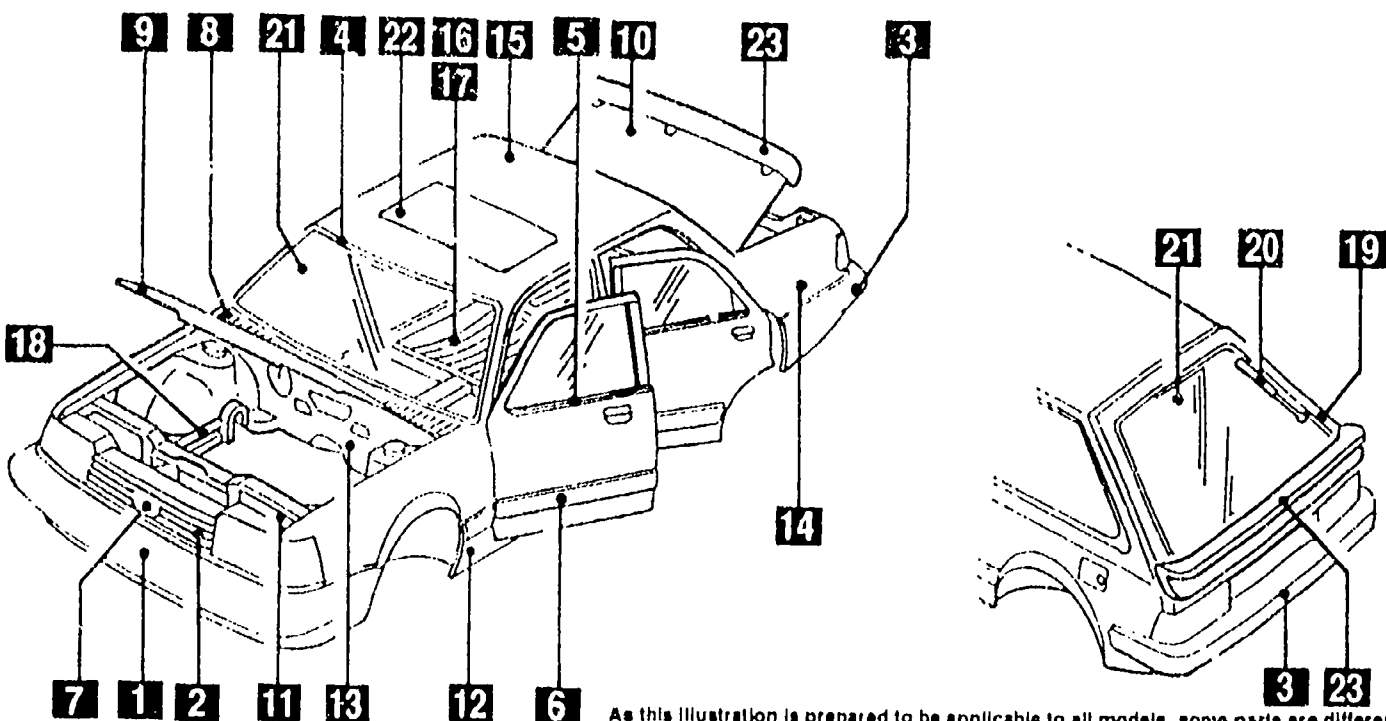
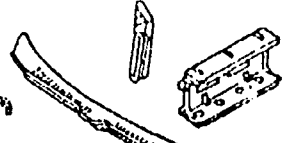
As this illustration is prepared to be applicable to all models, some parts are different in specifications from parts listed in this parts Catalog.

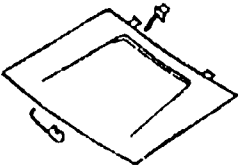
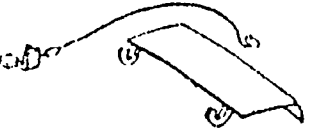

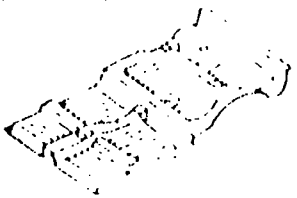
# PICTORIAL INDEX

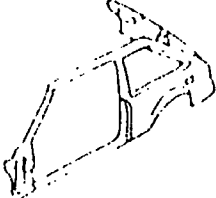
<b>1 0900</b>  KEY SETS	<b>2 5100</b>  HEAD LAMPS	<b>3 5105</b>  FRONT COMBINATION LAMPS	<b>4 5110</b>  REAR COMBINATION LAMPS	<b>5 5120</b>  LICENSE LAMP & REAR FINISHER	<b>6 5125</b>  INTERIOR LAMPS
<b>19 6750</b>  WINDOW WIPER & WASHER (REAR)	<h2 style="margin: 0;">BODY (1/4)</h2> 				<b>7 5130</b>  OVERHEAD CONSOLE
<b>18 6730</b>  WINDSHIELD WIPERS	<p style="text-align: center; font-size: small;">As this illustration is prepared to be applicable to all models, some parts are different in specifications from parts listed in this parts Catalog.</p>				<b>8 6600</b>  SWITCHES & RELAYS (ENGINE)
<b>17 6720</b>  WINDSHIELD WASHER					<b>21 5020</b>  HEAD LAMP CLEANER
<b>16 6704</b>  WIRING HARNESS CLAMPS	<b>14 6702</b>  WIRING HARNESSSES (DASHBOARD)	<b>13 6701</b>  WIRING HARNESSSES (ENGINE & T/MISSION)	<b>12 6700</b>  WIRING HARNESSSES (FRONT & REAR)	<b>11 6640</b>  AUTO CRUISE CONTROL SYSTEM	<b>10 6620</b>  DOOR SWITCH & HORNS
<b>15 6703</b>  WIRING HARNESSSES (DOOR, FLOOR/CEILING)					

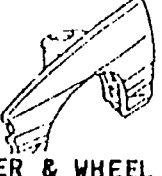
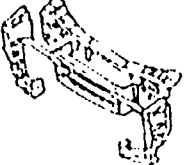
# PICTORIAL INDEX

<b>1 5000</b>  FRONT BUMPER	<b>2 5005</b>  RADIATOR GRILLE	<b>3 5010</b>  REAR BUMPER	<b>4 5030</b>  WINDOW MOULDINGS	<b>5 5040</b>  BODY MOULDINGS	<b>6 5060</b>  SIDE PROTECTORS	
<b>20 6230</b>  LIFT GATE MECHANISMS	<b>21 6300</b>  WINDOW GLASSES	<b>22 6330</b>  SUNROOF	<b>23 7800</b>  SPOILERS & RELATED PARTS	<b>7 5170</b>  ORNAMENTS		
<b>19 6200</b>  LIFT GATE	<h2 style="margin: 0;">BODY (2/4)</h2>  <p style="font-size: small; margin-top: 5px;">As this illustration is prepared to be applicable to all models, some parts are different in specifications from parts listed in this parts Catalog.</p>				<b>8 5180</b>  COWL & EXTRACTOR GRILLES	
<b>18 5390</b>  FLOOR ATTACHMENTS	<b>9 5230</b>  BONNET				<b>10 5260</b>  TRUNK LID	
<b>17 5380</b>  FLOOR ATTACHMENTS (HOLE COVERS)	<b>16 5370</b>  FLOOR PANELS	<b>15 5360</b>  ROOF PANELS	<b>14 5340</b>  SIDE PANELS	<b>13 5330</b>  DASH & COWL PANELS	<b>12 5320</b>  FENDER & WHEEL APRON PANELS	<b>11 5310</b>  FRONT PANELS

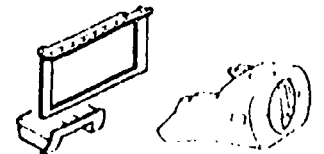
# PICTORIAL INDEX

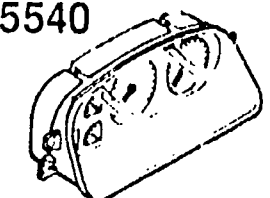
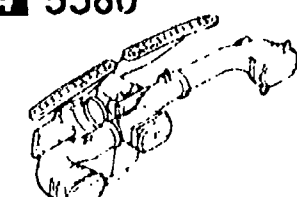
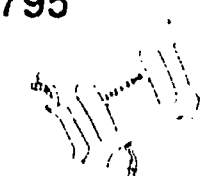
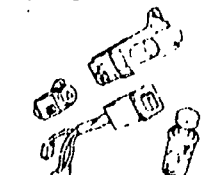
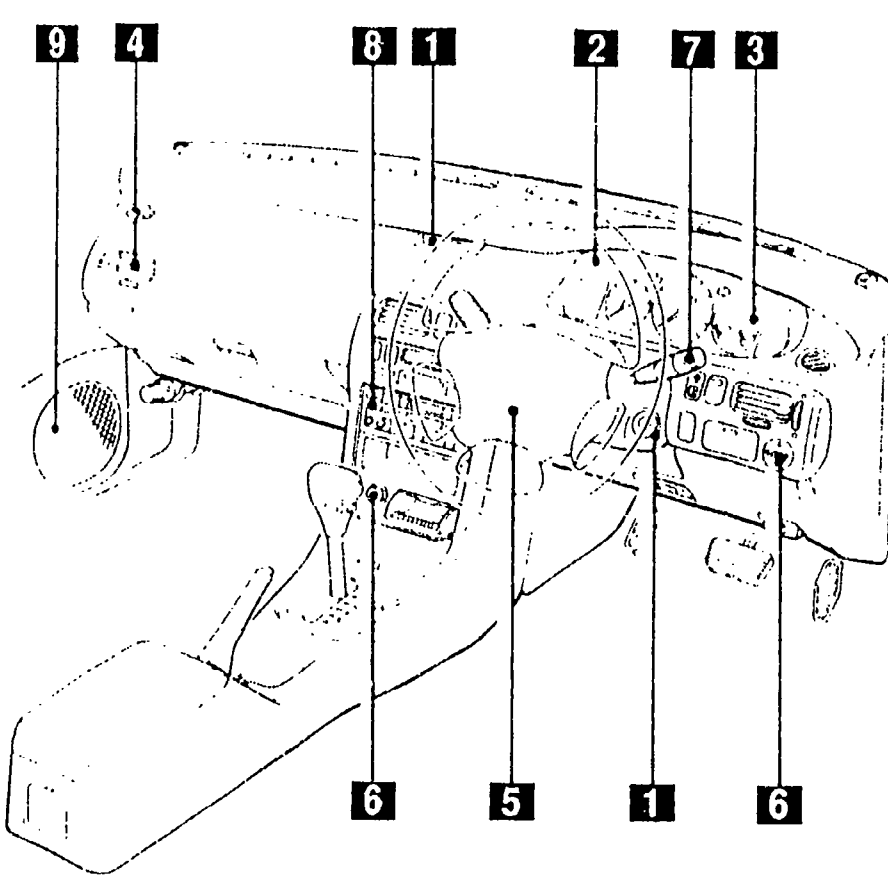
<p><b>1 5500</b></p>  <p>DASHBOARD EQUIPMENTS</p>	<p><b>2 5520</b></p>  <p>METER HOOD</p>	<p><b>3 5540</b></p>  <p>METER SET &amp; METER COMPONENTS</p>	<p><b>4 5580</b></p>  <p>VENTILATOR</p>	<p><b>5 5795</b></p>  <p>AIR BAG</p>	<p><b>6 6610</b></p>  <p>DASHBOARD SWITCHES</p>
<h2 style="margin: 0;">BODY (3/4)</h2> 					
<p style="font-size: small;">As this illustration is prepared to be applicable to all models, some parts are different in specifications from parts listed in this parts Catalog.</p>					

**7 6611**

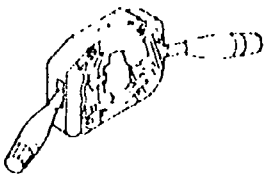

COMBINATION SWITCH

**8 6680**







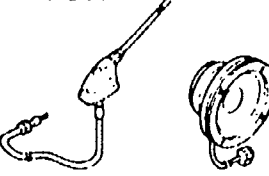

AUDIO SYSTEMS  
(RADIO & TAPE DECK)

**9 6682**

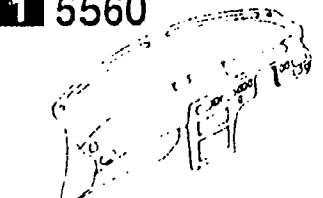
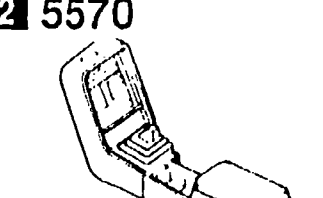
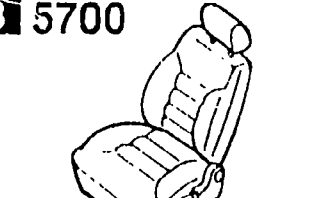
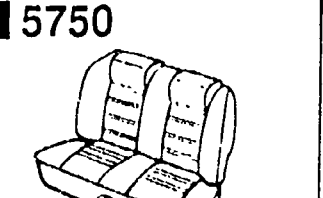
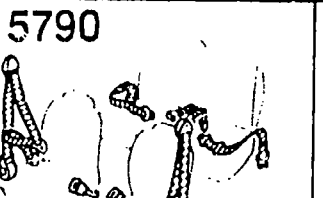
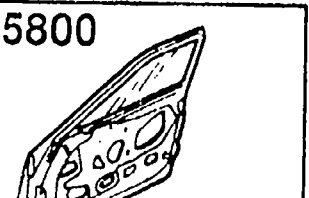
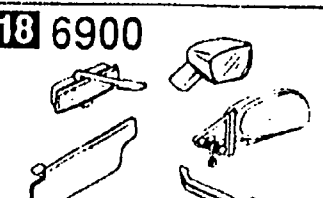

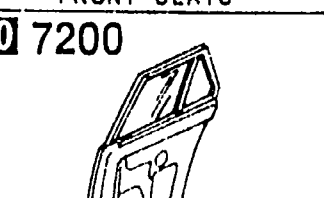
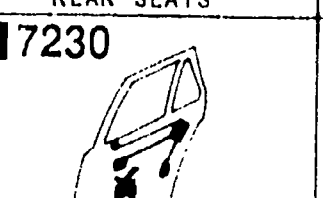
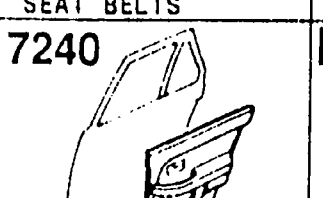
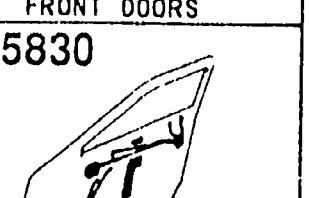
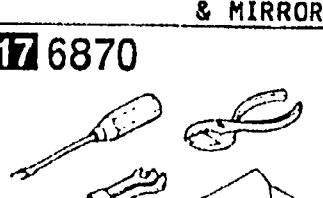
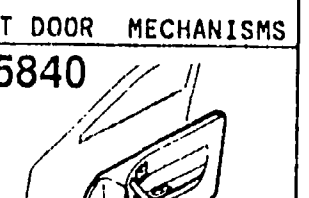
AUDIO SYSTEMS  
(ANTENNA & SPEAKER)

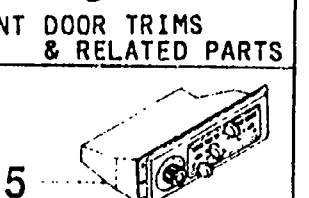
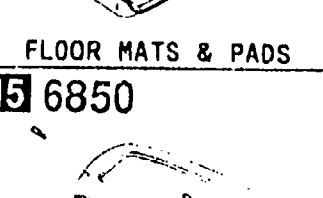
# PICTORIAL INDEX

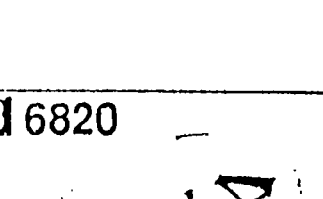
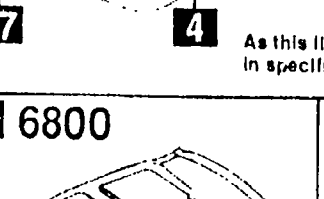
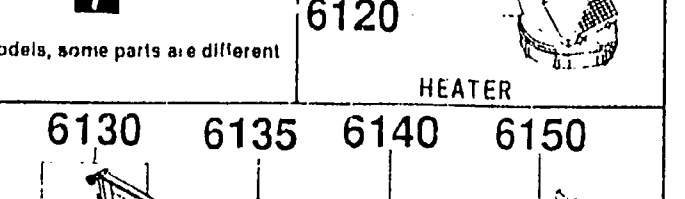
<p><b>1 5560</b></p>  <p>DASHBOARD &amp; RELATED PARTS</p>	<p><b>2 5570</b></p>  <p>CONSOLE</p>	<p><b>3 5700</b></p>  <p>FRONT SEATS</p>	<p><b>4 5750</b></p>  <p>REAR SEATS</p>	<p><b>5 5790</b></p>  <p>SEAT BELTS</p>	<p><b>6 5800</b></p>  <p>FRONT DOORS</p>
<p><b>18 6900</b></p>  <p>VISORS, ASSIST HANDLES &amp; MIRRORS</p>	<p><b>19 6930</b></p>  <p>CAUTION PLATES &amp; LABELS</p>	<p><b>20 7200</b></p>  <p>REAR DOORS</p>	<p><b>21 7230</b></p>  <p>REAR DOOR MECHANISMS</p>	<p><b>22 7240</b></p>  <p>REAR DOOR TRIMS &amp; RELATED PARTS</p>	<p><b>7 5830</b></p>  <p>FRONT DOOR MECHANISMS</p>
<p><b>17 6870</b></p>  <p>SERVICE TOOLS</p>	<div style="display: flex; justify-content: space-between; align-items: center;"> <div style="text-align: center;"> <p><b>15</b></p> </div> <div style="text-align: center;"> <p><b>13</b></p> </div> <div style="text-align: center;"> <p><b>12</b></p> </div> <div style="text-align: center;"> <p><b>5</b></p> </div> <div style="text-align: center;"> <p><b>3</b></p> </div> <div style="text-align: center;"> <p><b>2</b></p> </div> <div style="text-align: center;"> <p><b>9</b></p> </div> <div style="text-align: center;"> <p><b>1</b></p> </div> <div style="text-align: center;"> <p><b>10</b></p> </div> <div style="text-align: center;"> <p><b>18</b></p> </div> </div> <div style="text-align: center; font-size: 2em; font-weight: bold; margin: 10px 0;">             BODY (4/4)         </div> <div style="display: flex; justify-content: space-between; align-items: center;"> <div style="text-align: center;"> <p><b>17</b></p> </div> <div style="text-align: center;"> <p><b>4</b></p> </div> <div style="text-align: center;"> <p><b>14</b></p> </div> <div style="text-align: center;"> <p><b>22</b></p> </div> <div style="text-align: center;"> <p><b>20</b> <b>21</b></p> </div> <div style="text-align: center;"> <p><b>16</b></p> </div> <div style="text-align: center;"> <p><b>8</b></p> </div> <div style="text-align: center;"> <p><b>19</b></p> </div> <div style="text-align: center;"> <p><b>6</b> <b>7</b></p> </div> </div>				<p><b>8 5840</b></p>  <p>FRONT DOOR TRIMS &amp; RELATED PARTS</p>
<p><b>16 6860</b></p>  <p>FLOOR MATS &amp; PADS</p>	<p style="font-size: 0.8em;">As this illustration is prepared to be applicable to all models, some parts are different in specifications from parts listed in this parts Catalog</p>				<p><b>9</b></p>  <p>HEATER</p>
<p><b>15 6850</b></p>  <p>LUGGAGE COVER</p>	<p><b>14 6840</b></p>  <p>TRIMS &amp; SCUFF PLATES</p>	<p><b>13 6820</b></p>  <p>PILLAR TRIMS</p>	<p><b>12 6800</b></p>  <p>CEILING TRIMS</p>	<p><b>10</b></p>  <p>AIR CONDITIONER</p>	

## SECTION NAME INDEX (ENGINE)

LO NO	SEC NO	SECTION NAME	LO NO	SEC NO	SECTION NAME	LO NO	SEC NO	SECTION NAME
1-C03	1000AA	SHORT & PARTIAL ENGINE (1600CC)	1-E06	1364AB	THROTTLE BODY (2000CC)	1-G11	1840AB	STARTER (2000CC)(HT)
1-DC3	1000AB	SHORT & PARTIAL ENGINE (2000CC)	1-F06	1370AA	EMISSION CONTROL SYSTEM (INLET SIDE) (1600CC)	1-111	1340AC	STARTER (2000CC)(AT)
1-E03	1005AA	ENGINE GASKET SETS (1600CC)	1-H06	1370AB	EMISSION CONTROL SYSTEM (INLET SIDE) (2000CC)	1-K11	1850A	BATTERY
1-F03	1005AB	ENGINE GASKET SETS (2000CC)	1-L06	1400AA	OIL PUMP & FILTER (1600CC)	1-L11	1910A	AUTOMATIC TRANSMISSION TORQUE CONVERTER, OIL PUMP & PIPINGS
1-G03	1010AA	CYLINDER HEAD & COVER (1600CC)	1-N06	1400AB	OIL PUMP & FILTER (2000CC)	1-E12	1920A	AUTOMATIC TRANSMISSION CASE & MAIN CONTROL SYSTEM
1-I03	1010AB	CYLINDER HEAD & COVER (2000CC)	1-D07	1500AA	COOLING SYSTEM (1600CC)	1-H12	1925A	AUTOMATIC TRANSMISSION CONTROL VALVE
1-L03	1030AA	CYLINDER BLOCK (1600CC)	1-H07	1500AB	COOLING SYSTEM (2000CC)	1-L12	1930A	AUTOMATIC TRANSMISSION CLUTCH S & PLANETARY GEARS
1-M03	1030AB	CYLINDER BLOCK (2000CC)	1-L07	1580AA	BRACKET, PULLEY & BELT (1600CC)	1-D13	1940A	AUTOMATIC TRANSMISSION GOVERNO R, LOW & REVERSE PISTON
1-N03	1040AA	OIL PAN & TIMING COVER (1600CC)	1-N07	1580AB	BRACKET, PULLEY & BELT (2000CC)	1-G13	1950A	AUTOMATIC TRANSMISSION MANUAL LINKAGE SYSTEM
1-D04	1040AB	OIL PAN & TIMING COVER (2000CC)	1-C09	1600AA	CLUTCH DISC & COVER (1600CC)	1-I13	1960A	AUTOMATIC TRANSMISSION GASKET & SEAL KIT
1-F04	1100AA	PISTON, CRANKSHAFT & FLYWHEEL (1600CC)	1-D09	1600AB	CLUTCH DISC & COVER (2000CC)			
1-H04	1100AB	PISTON, CRANKSHAFT & FLYWHEEL (2000CC)	1-E09	1700AA	MANUAL TRANSMISSION CASE (1600CC)			
1-J04	1200AA	VALVE SYSTEM (1600CC)	1-G09	1700AB	MANUAL TRANSMISSION CASE (2000CC)			
1-L04	1200AB	VALVE SYSTEM (2000CC)	1-I09	1710AA	MANUAL TRANSMISSION GEARS (1600CC)			
1-C05	1300AA	INLET MANIFOLD (1600CC)	1-M09	1710AB	MANUAL TRANSMISSION GEARS (2000CC)			
1-D05	1300AB	INLET MANIFOLD (2000CC)	1-E10	1720AA	MANUAL TRANSMISSION CHANGE CON TROL SYSTEM (1600CC)			
1-E05	1310AA	EXHAUST MANIFOLD (1600CC)	1-G10	1720AB	MANUAL TRANSMISSION CHANGE CON TROL SYSTEM (2000CC)			
1-G05	1310AB	EXHAUST MANIFOLD (2000CC)	1-I10	1800AA	ENGINE ELECTRICAL SYSTEM (1600CC)			
1-H05	1320AA	FUEL SYSTEM	1-K10	1800AB	ENGINE ELECTRICAL SYSTEM (2000CC)			
1-I05	1325AA	FUEL DISTRIBUTOR (1600CC)	1-K10	1830AA	ALTERNATOR (1600CC)			
1-J05	1325AB	FUEL DISTRIBUTOR (2000CC)	1-C11	1830AB	ALTERNATOR (2000CC)			
1-L05	1330AA	AIR CLEANER (1600CC)	1-E11	1840AA	STARTER (1600CC)			
1-N05	1330AB	AIR CLEANER (2000CC)						
1-D06	1364AA	THROTTLE BODY (1600CC)						

## SECTION NAME INDEX (CHASSIS)

LO NO	SEC NO	SECTION NAME	LO NO	SEC NO	SECTION NAME	LO NO	SEC NO	SECTION NAME
2-C05	2510AA	FRONT DRIVE SHAFTS (1600CC)(MT)	2-C08	3900AA	ENGINE & TRANSMISSION MOUNTING S (MANUAL TRANSMISSION) (1600CC)	2-L11	4360AB	BRAKE PIPINGS (W/O ANTILOCK BRAKE)(2000CC)(4- DOOR)
2-E03	2510AB	FRONT DRIVE SHAFTS (1600CC)(AT)	2-E08	3900AB	ENGINE & TRANSMISSION MOUNTING S (MANUAL TRANSMISSION) (2000CC)	2-D12	4360AC	BRAKE PIPINGS (W/O ANTILOCK BRAKE)(2000CC)(5- DOOR)
2-G03	2510AC	FRONT DRIVE SHAFTS (2000CC)(MT)	2-G08	3900BA	ENGINE & TRANSMISSION MOUNTING S (AUTOMATIC TRANSMISSION) (1600CC)	2-F12	4360BA	BRAKE PIPINGS (W/ANTILOCK BRAKE)(1600CC)
2-I03	2510AD	FRONT DRIVE SHAFTS (2000CC)(AT)	2-I08	3900BB	ENGINE & TRANSMISSION MOUNTING S (AUTOMATIC TRANSMISSION) (2000CC)	2-H12	4360BB	BRAKE PIPINGS (W/ANTILOCK BRAKE)(2000CC)(4-D OOR)
2-K03	2600AA	REAR AXLE (DRUM BRAKE)	2-K08	4000A	EXHAUST SYSTEM (1600CC)	2-K12	4360BC	BRAKE PIPINGS (W/ANTILOCK BRAKE)(2000CC)(5-D OOR)
2-L03	2600AB	REAR AXLE (DISC BRAKE)(4-DOOR)	2-M08	4000B	EXHAUST SYSTEM (2000CC)	2-M12	4270A	ANTILOCK BRAKE SYSTEM
2-M03	2600AC	REAR AXLE (DISC BRAKE)(5-DOOR)(W/O ANTI LOCK BRAKE)	2-C09	4140A	CLUTCH RELEASE & MASTER CYLIND ERS (MANUAL TRANSMISSION)	2-N12	4400A	PARKING BRAKE SYSTEM
2-N03	2600AD	REAR AXLE (DISC BRAKE)(5-DOOR)(W/ANTILOC K BRAKE)	2-F09	4145AA	CLUTCH PIPINGS (MANUAL TRANSMI SSION) (1600CC)	2-D13	4500A	FUEL PIPINGS
2-C04	2610AA	REAR BRAKE MECHANISMS (DRUM BRAKE)	2-G09	4145AB	CLUTCH PIPINGS (MANUAL TRANSMI SSION) (2000CC)	2-F13	4600A	CHANGE CONTROL SYSTEM (MANUAL TRANSMISSION)
2-E04	2610AB	REAR BRAKE MECHANISMS (DISC BRAKE)	2-H09	4160A	ACCELERATOR CONTROL SYSTEM	2-G13	4600B	CHANGE CONTROL SYSTEM (AUTOMAT IC TRANSMISSION)
2-G04	2700A	FRONT DIFFERENTIALS (MT)	2-J09	4200A	FUEL TANK			
2-J04	2700B	FRONT DIFFERENTIALS (AT)	2-F10	4210A	FUEL LID OPENER (4-DOOR)			
2-L04	2800A	REAR SUSPENSION MECHANISMS	2-H10	4210AA	FUEL LID OPENER (5-DOOR)			
2-D05	2810A	REAR STABILIZER	2-I10	4300A	CLUTCH & BRAKE PEDALS (MANUAL TRANSMISSION)			
2-E05	3200A	STEERING WHEEL	2-K10	4300B	BRAKE PEDALS (AUTOMATIC TRANSM ISSION)			
2-K05	3210A	STEERING COLUMN & SHAFTS	2-L10	4340A	BRAKE MASTER CYLINDER & POWER BRAKE (W/O ANTILOCK BRAKE)(4-DOOR)			
2-L05	3220A	STEERING GEAR	2-C11	4340AA	BRAKE MASTER CYLINDER & POWER BRAKE (W/O ANTILOCK BRAKE)(5-DOOR)			
2-C06	3240AA	POWER STEERING SYSTEM (1600CC)	2-E11	4340B	BRAKE MASTER CYLINDER & POWER BRAKE (W/ANTILOCK BRAKE)(4-DOOR)			
2-G06	3240AB	POWER STEERING SYSTEM (2000CC)	2-H11	4340BA	BRAKE MASTER CYLINDER & POWER BRAKE (W/ANTILOCK BRAKE)(5-DOOR)			
2-K06	3300A	FRONT AXLE	2-J11	4360AA	BRAKE PIPINGS (W/O ANTILOCK BRAKE)(1600CC)			
2-M06	3310AA	FRONT BRAKE MECHANISMS (1600CC)						
2-N06	3310AB	FRONT BRAKE MECHANISMS (2000CC)						
2-D07	3400A	FRONT SUSPENSION MECHANISMS						
2-G07	3410A	COSSMEMBER & STABILIZER						
2-H07	3700A	TIRES & JACK						

## SECTION NAME INDEX (BODY)

LO NO	SEC NO	SECTION NAME	LO NO	SEC NO	SECTION NAME	LO NO	SEC NO	SECTION NAME
3-C03	0900A	KEY SETS (4-DOOR)	3-C07	5170A	ORNAMENTS (4-DOOR)	3-I12	5560A	DASHBOARD & RELATED PARTS
3-F03	0900AA	KEY SETS (5-DOOR)	3-E07	5170AA	ORNAMENTS (5-DOOR)	3-L12	5570A	CONSOLE
3-H03	5000A	FRONT BUMPER (4-DOOR)	3-F07	5180A	COWL & EXTRACTOR GRILLES (4-DOOR)	3-D13	5580A	VENTILATOR
3-L03	5000AA	FRONT BUMPER (5-DOOR)	3-H07	5180B	COWL & EXTRACTOR GRILLES (5-DOOR)	3-F13	5700A	FRONT SEATS (4-DOOR)
3-N03	5005A	RADIATOR GRILLE (4-DOOR)	3-J07	5230A	BONNET	3-N14	5700B	FRONT SEATS (5-DOOR)
3-D04	5005AA	RADIATOR GRILLE (5-DOOR)	3-L07	5260A	TRUNK LID (4-DOOR)	3-I15	5750A	REAR SEATS (4-DOOR)
3-E04	5010A	REAR BUMPER (4-DOOR)	3-N07	5310A	FRONT PANELS	3-F16	5750B	REAR SEATS (5-DOOR)
3-G04	5010B	REAR BUMPER (5-DOOR)	3-C08	5320A	FENDER & WHEEL APRON PANELS (4-DOOR)	3-J16	5790A	SEAT BELTS (4-DOOR)
3-I04	5030A	WINDOW MOULDINGS (4-DOOR)	3-G08	5320AA	FENDER & WHEEL APRON PANELS (5-DOOR)	3-M16	5790B	SEAT BELTS (5-DOOR)
3-J04	5030B	WINDOW MOULDINGS (5-DOOR)	3-K08	5330A	DASH & COWL PANELS	4-C03	5795A	AIR BAG
3-K04	5040A	BODY MOULDINGS (4-DOOR)	3-L08	5340A	SIDE PANELS (4-DOOR)	4-E03	5800A	FRONT DOORS
3-M04	5040B	BODY MOULDINGS (5-DOOR)	3-E09	5340B	SIDE PANELS (5-DOOR)	4-H03	5830A	FRONT DOOR MECHANISMS (4-DOOR)
3-H05	5060A	SIDE PROTECTORS (4-DOOR)	3-J09	5360A	ROOF PANELS (4-DOOR)	4-N03	5830AA	FRONT DOOR MECHANISMS (5-DOOR)
3-K05	5060AA	SIDE PROTECTORS (5-DOOR)	3-K09	5360B	ROOF PANELS (5-DOOR)	4-F04	5840A	FRONT DOOR TRIMS & RELATED PARTS (4-DOOR)
3-M05	5100A	HEAD LAMPS (4-DOOR)	3-M09	5370A	FLOOR PANELS (4-DOOR)	4-N04	5840AA	FRONT DOOR TRIMS & RELATED PARTS (5-DOOR)
3-N05	5100B	HEAD LAMPS (5-DOOR)	3-D10	5370B	FLOOR PANELS (5-DOOR)	4-C06	6100A	HEATER
3-C06	5105A	FRONT COMBINATION LAMPS (4-DOOR)	3-G10	5380A	FLOOR ATTACHMENT (HOLE COVERS) (4-DOOR)	4-E06	6110A	HEATER UNIT COMPONENTS
3-F06	5105B	FRONT COMBINATION LAMPS (5-DOOR)	3-I10	5380B	FLOOR ATTACHMENT (HOLE COVERS) (5-DOOR)	4-G06	6115A	HEATER CONTROL COMPONENTS
3-G06	5110A	REAR COMBINATION LAMPS (4-DOOR)	3-K10	5390A	FLOOR ATTACHMENT (4-DOOR)	4-I06	6120A	HEATER BLOWER COMPONENTS
3-I06	5110B	REAR COMBINATION LAMPS (5-DOOR)	3-N10	5390B	FLOOR ATTACHMENT (5-DOOR)	4-J06	6130A	AIR CONDITIONER
3-J06	5120A	LICENSE LAMPS	3-C12	5500A	DASHBOARD EQUIPMENTS	4-C07	6135A	AIR CONDITIONING COOLING PIPE O-RING
3-L06	5125A	INTERIOR LAMPS (W/O SUNROOF)	3-E12	5520A	METER HOOD	4-D07	6140A	AIR CONDITIONING COMPRESSOR COMPONENTS (1600CC)
3-M06	5125B	INTERIOR LAMPS (W/SUNROOF)	3-F12	5540AA	METER SET & METER COMPONENTS (4-DOOR)(W/O TACHOMETER)	4-E07	6140B	AIR CONDITIONING COMPRESSOR COMPONENTS (2000CC)
3-N06	5130A	OVERHEAD CONSOLE (W/SUNROOF)	3-G12	5540AB	METER SET & METER COMPONENTS (4-DOOR)(W/TACHOMETER)	4-F07	6150A	AIR CONDITIONING COOLING UNIT
			3-H12	5540B	METER SET & METER COMPONENTS (5-DOOR)	4-H07	6200A	LIFT GATE (5-DOOR)
						4-I07	6230A	LIFT GATE MECHANISMS (5-DOOR)



## SECTION NAME INDEX (BODY)

LO NO	SEC NO	SECTION NAME	LO NO	SEC NO	SECTION NAME	LO NO	SEC NO	SECTION NAME
4-J07	6300A	WINDOW GLASSES (4-DOOR)	4-L11	6703AA	DOOR, FLOOR & CEILING WIRING H ARNESSES (5-DOOR)	5-E03	7800AA	SPOILERS & RELATED PARTS (5-DOOR)
4-K07	6300B	WINDOW GLASSES (5-DOOR)	4-M11	6704A	WIRING HARNESS CLAMPS (4-DOOR)			
4-M07	6330A	SUNROOF (4-DOOR)	4-D12	6704AA	WIRING HARNESS CLAMPS (5-DOOR)			
4-D08	6330B	SUNROOF (5-DOOR)	4-E12	6720A	WINDSHIELD WASHER (4-DOOR)			
4-G08	6600AA	ENGINE SWITCHES & RELAYS (1600CC)	4-H12	6720AA	WINDSHIELD WASHER (5-DOOR)			
4-X08	6600AB	ENGINE SWITCHES & RELAYS (2000CC)	4-K12	6730A	WINDSHIELD WIPERS			
4-C09	6610A	DASHBOARD SWITCHES	4-M12	6750A	WINDOW WIPER & WASHER (REAR) (5-DOOR)			
4-D09	6611A	COMBINATION SWITCH	4-C13	6800A	CEILING TRIMS (4-DOOR)			
4-E09	6620A	DOOR SWITCH & HORNS	4-E13	6800B	CEILING TRIMS (5-DOOR)			
4-F09	6630A	BODY RELAYS & UNIT (4-DOOR)	4-G13	6820A	PILLAR TRIMS (4-DOOR)			
4-G09	6630B	BODY RELAYS & UNIT (5-DOOR)	4-J13	6820B	PILLAR TRIMS (5-DOOR)			
4-H09	6640A	AUTO CRUISE CONTROL SYSTEM	4-M13	6840A	TRIMS & SCUFF PLATES (4-DOOR)			
4-K09	6680A	AUDIO SYSTEMS (RADIO & TAPE DE CK) (4-DOOR)	4-E14	6840B	TRIMS & SCUFF PLATES (5-DOOR)			
4-E10	6680AA	AUDIO SYSTEMS (RADIO & TAPE DE CK) (5-DOOR)	4-H14	6850A	LUGGAGE COVER (5-DOOR)			
4-F10	6682A	AUDIO SYSTEMS (ANTENNA & SPEAK ER) (4-DOOR)	4-I14	6860A	FLOOR MATS & PADS (4-DOOR)			
4-G10	6682AA	AUDIO SYSTEMS (ANTENNA & SPEAK ER) (5-DOOR)	4-L14	6860B	FLOOR MATS & PADS (5-DOOR)			
4-I10	6700A	FRONT & REAR WIRING HARNESSES (4-DOOR)	4-N14	6870A	SERVICE TOOLS			
4-L10	6700B	FRONT & REAR WIRING HARNESSES (5-DOOR)	4-C15	6900A	SUN VISORS, ASSIST HANDLES & M IRRORS (4-DOOR)			
4-C11	6701AA	ENGINE & TRANSMISSION WIRING H ARNESSES (1600CC)	4-H15	6900AA	SUN VISORS, ASSIST HANDLES & M IRRORS (5-DOOR)			
4-F11	6701AB	ENGINE & TRANSMISSION WIRING H ARNESSES (2000CC)	4-K15	6930A	CAUTION PLATES & LABELS			
4-I11	6702A	DASHBOARD WIRING HARNESSES	4-N15	7200A	REAR DOORS			
4-K11	6703A	DOOR, FLOOR & CEILING WIRING H ARNESSES (4-DOOR)	4-F16	7230A	REAR DOOR MECHANISMS			
			4-K16	7240A	REAR DOOR TRIMS & RELATED PART S			
			5-C03	7800A	SPOILERS & RELATED PARTS (4-DOOR)			

(W/O POWER DOOR LOCK)

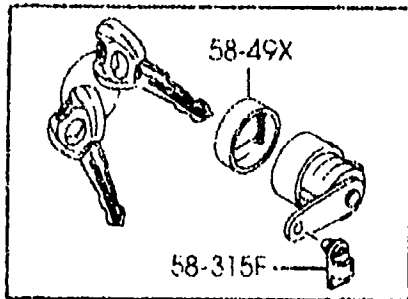
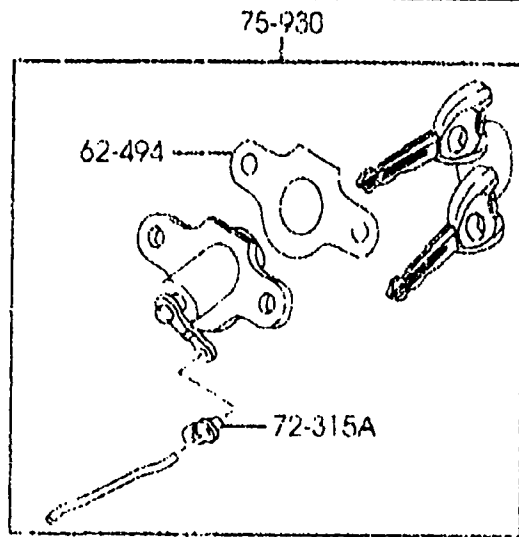
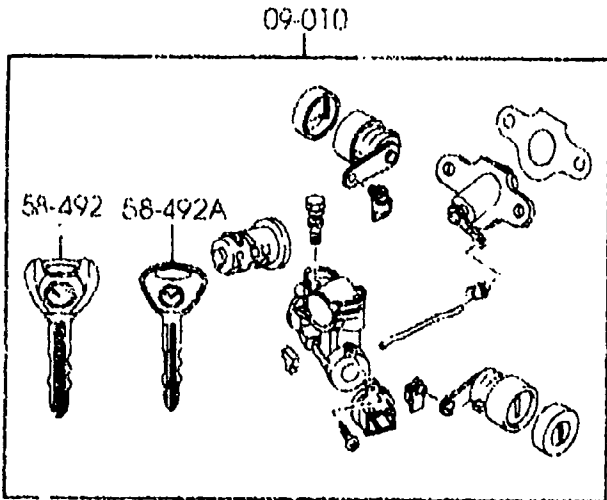

75-910

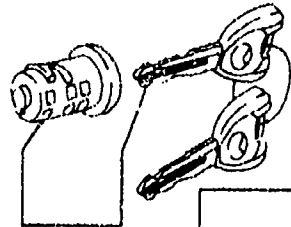

75-990

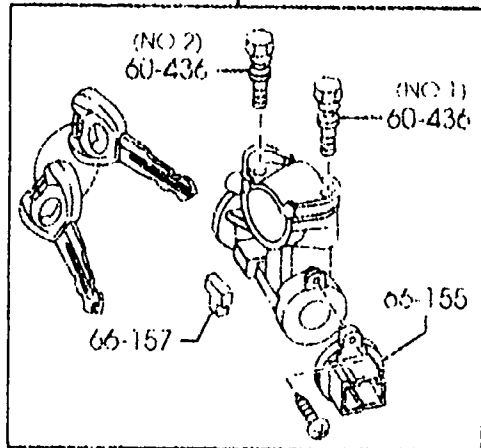

75-980

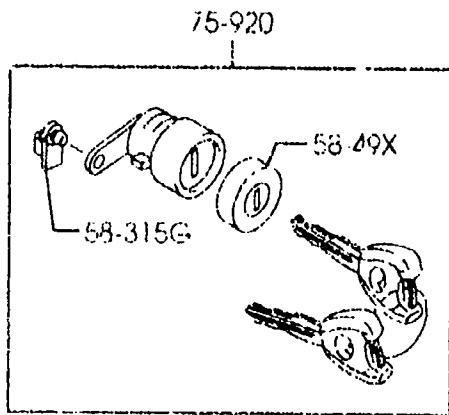

75-920

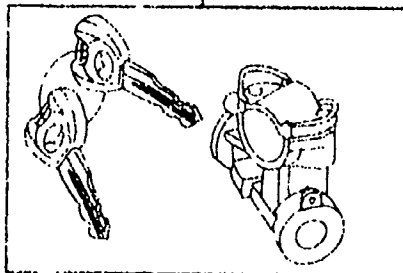

KEY, BLANK  
-PRIMARY

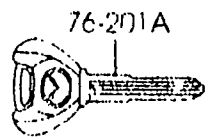

KEY, BLANK  
-SECONDARY

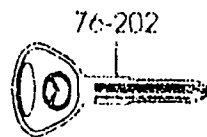

(W/ POWER DOOR LOCK)

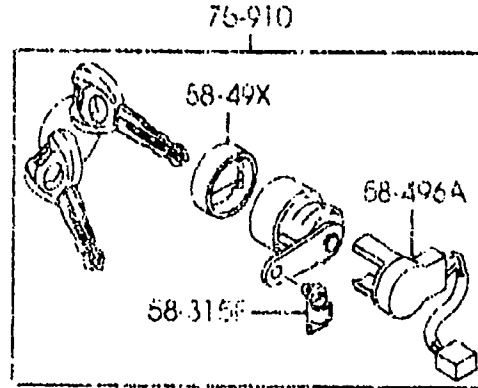
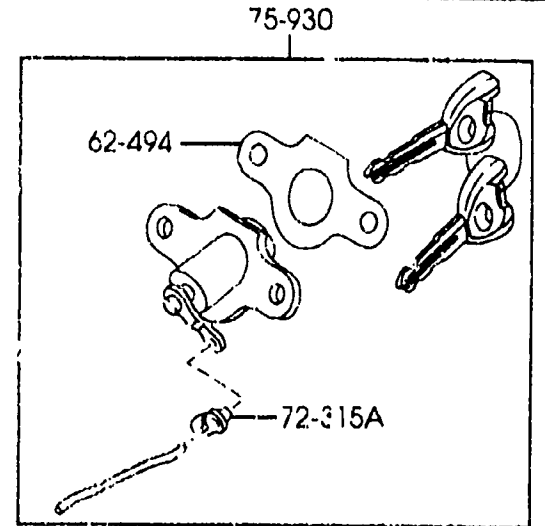
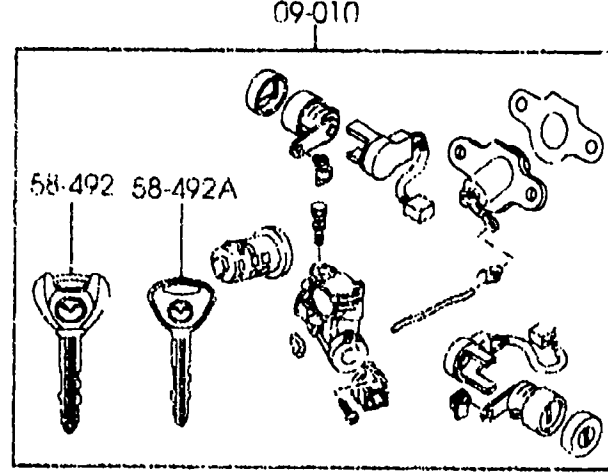

58-496A

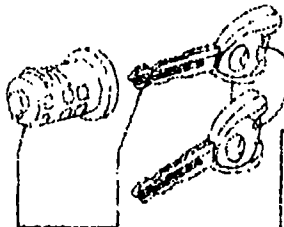

75-990

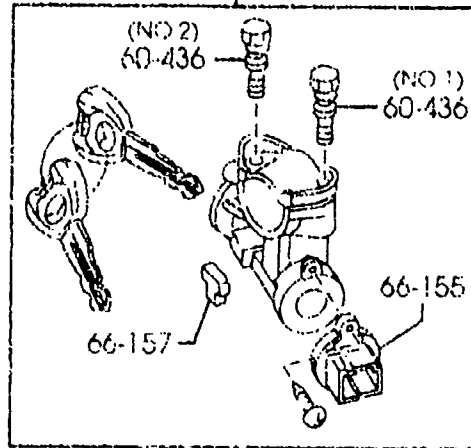

75-980

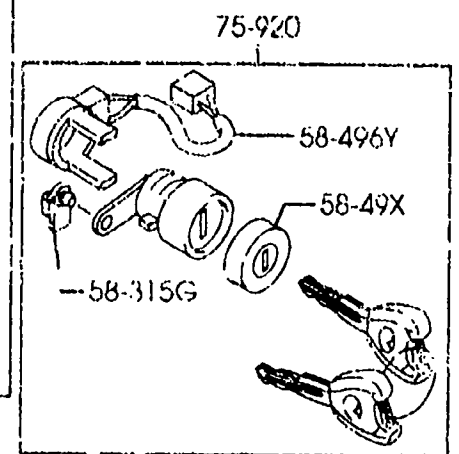

75-920

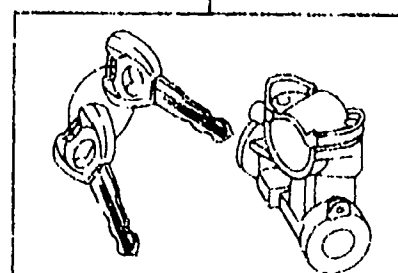

KEY, BLANK  
-PRIMARY

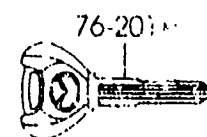

KEY, BLANK  
-SECONDARY

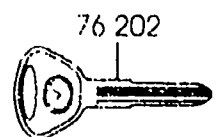

(W/O POWER DOOR LOCK)

09-010

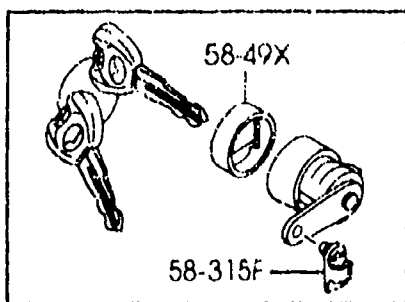
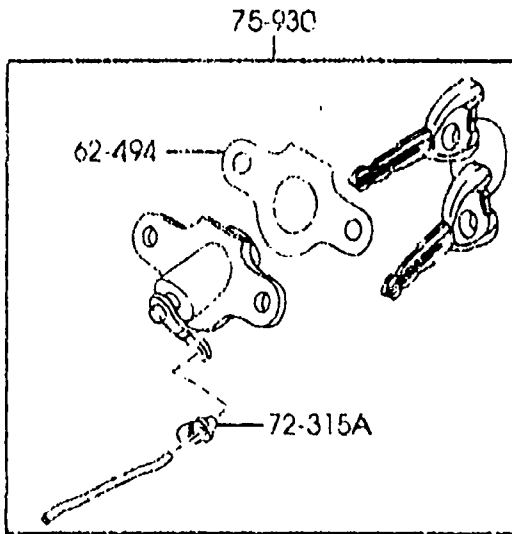
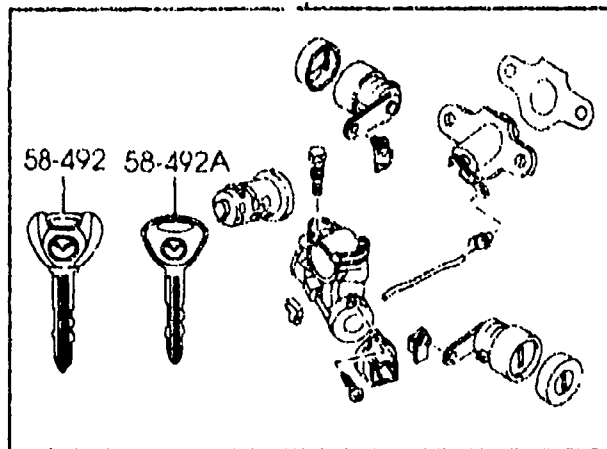

75-910

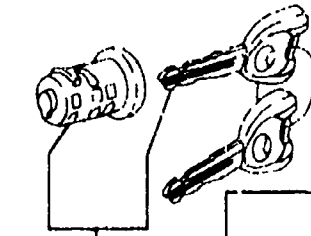

75-990

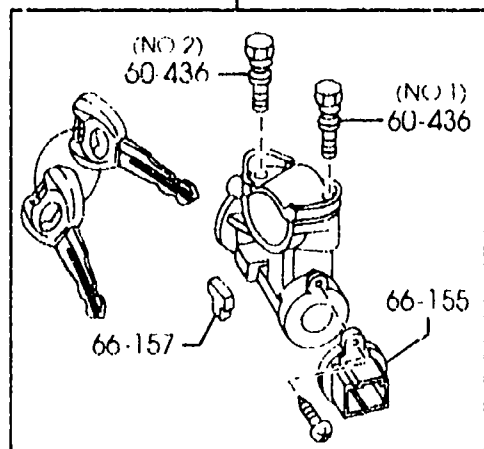

75-980

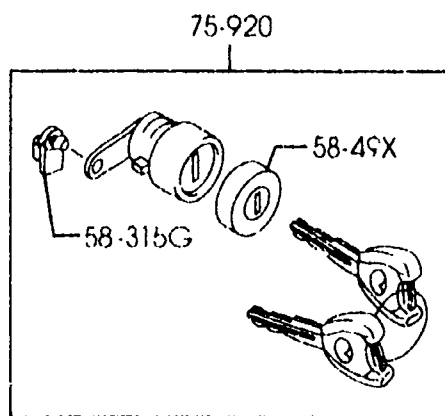

75-920

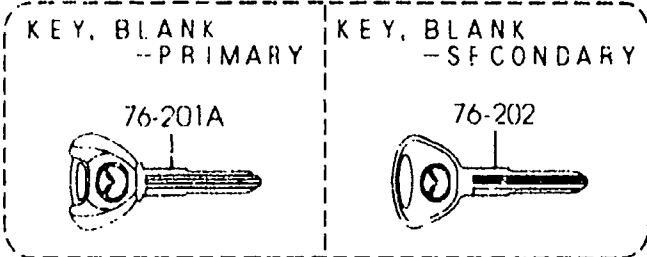
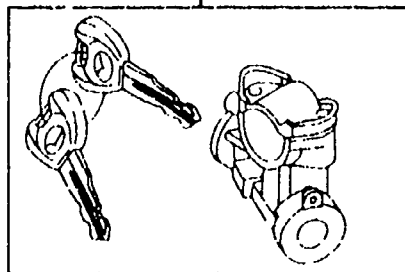

PART NO.	QTY	MODEL/RESTRICTION	MODEL/RESTRICTION	MODEL/RESTRICTION	FROM-TO
09-010		KEY SET	JEU DE BARILLET		
BL8D-09-010	1	(W/O POWER DR LOCK) (MT)	(B.V.MANU)		
BL8E-09-010	1	(W/POWER DR LOCK) (MT)	(B.V.MANU)		
BL8H-09-010	1	(W/O POWER DR LOCK) (AT)	(B.V.AUTOM)		
FL8J-09-010	1	(W/POWER DR LOCK) (AT)	(B.V.AUTOM)		
58-315F		CLIP(R), LOCK	ATTACHE		
R001-58-315A	1				
58-315G		CLIP(L), LOCK	ATTACHE		
B001-59-315	1				
58-49X		CAP, KEY CYLINDER	CAPUCHON CLAVETTE CYLINDER		
B25D-58-49X	2	STEEL	STEEL		
58-492		KEY, PRIMARY	CLEF, PRIMAIRE		
GD7B-58-492A	1	KEY NO. IS REQUIRED	KEY NO. IS REQUIRED		
58-492A		KEY, SECONDARY	CLE DE RESERVE		
GD7B-58-493	1	KEY NO. IS REQUIRED	KEY NO. IS REQUIRED		
58-496A		SWITCH(R), LOCK-CYLINDER	INTERRUPT.(D), VERROU-CYL.		
BJ0E-58-498	1	(W/POWER DR LOCK)			
58-496Y		SWITCH(L), LOCK-CYLINDER	INTERRUPT.(G), VERROU-CYL.		
BJ0E-59-498	1	(W/POWER DR LOCK)			
60-436		BOLT, SET	BOULON, JEU		
H043-66-154	1	(ILLUST. NO.1)			
KA01-66-154	1	(ILLUST. NO.2)			
62-494		GASKET, LOCK CYLINDER	JOINT, CYLINDRE VERROUILL.		
B25D-56-904	1				
66-155		SWITCH, IGNITION	CONTACT D'ALLUMAGE		
LC70-66-151	1				

(W/POWER DOOR LOCK)  
09-010

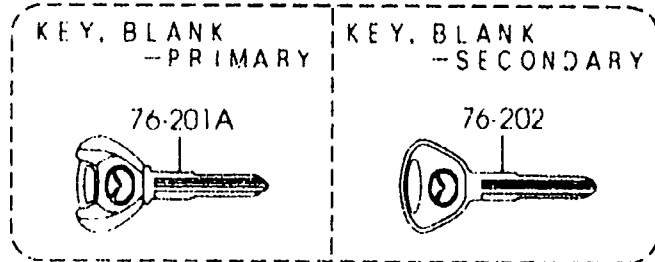
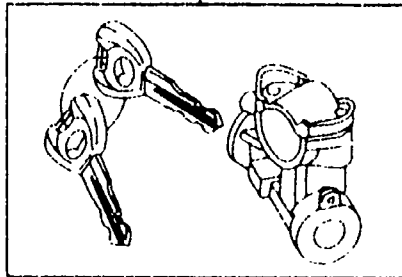
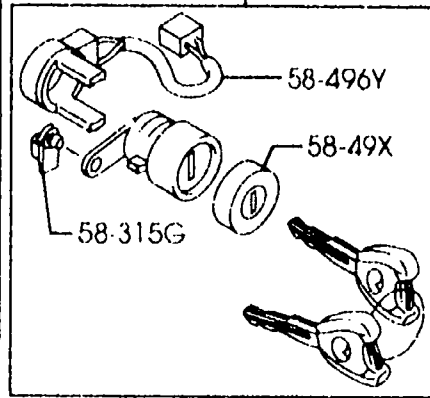
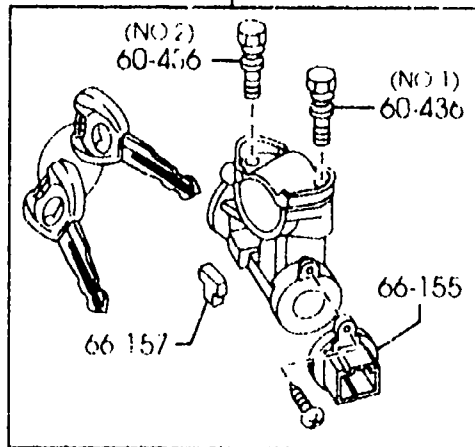
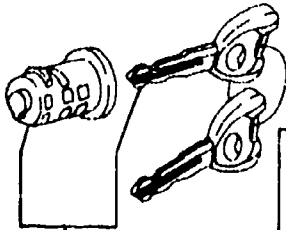
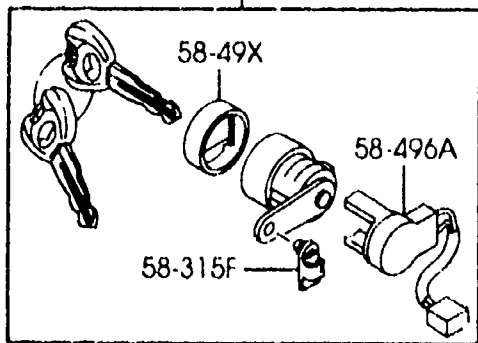
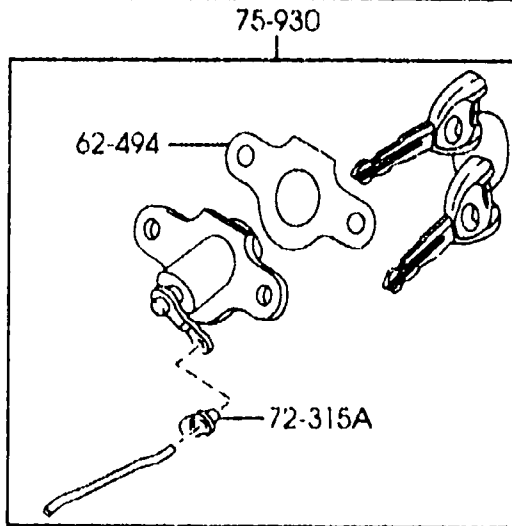
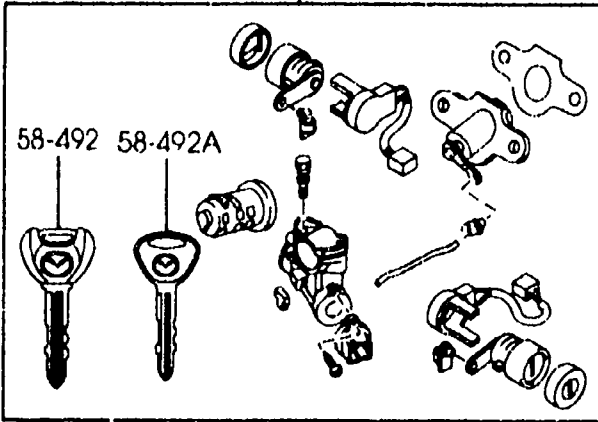

PART NO.	QTY	MODEL/RESTRICTION	MODEL/RESTRICTION	MODEL/RESTRICTION	FROM-TO
66-157 GE4T-66-157	1	SWITCH,KEY LESS-IG.S WITCH	INTERRUPT.,KEY LESS- IN.CO		
72-315A BTAJ-62-492	1	CLIP	CLIP		
75-910 BJYE-76-210B B2YD-76-210A	1 1	KEY SUB SET(R),DOOR (W/POWER DR LOCK) (W/O POWER DR LOCK)	JEU DE BARILLET (D), PORIE		
75-920 BJYE-76-220B B2YD-76-220A	1 1	KEY SUB SET(L),DOOR (W/POWER DR LOCK) (W/O POWER DR LOCK)	JEU DE BARILLET (G), PORTE		
75-930 B2YD-76-230A	1	KEY SUB SET,TRUNK	JEU DE BARILLET, COF FRE		
75-950 BG1N-76-250B	1	KEY SUB SET,GLOVE	JEU DE BARILLET, BOI TE A GANTS		
75-980 BJYE-76-140 GEYM-76-140	1 1	KEY SUB SET,IG.SWICH (MT) (AT)	SOUS-JEU, (B.V.MANU) (B.V.AUTOM)		
75-990 BLYD-76-290 GGYB-76-290	1 1	KEY SUB SET,ST. LOCK (MT) (AT)	SOUS-JEU, (B.V.MANU) (B.V.AUTOM)		
76-201A GD7B-76-201A	1	KEY,BLANK-PRIMARY	CLE,PLEIN-PRIMAIRE		
76-202 GD7B-76-202	1	KEY,BLANK-SECONDARY	CLE,PLEIN-SCONDAIRE		

0900AA KEY SETS  
(5-DOOR)

0900AA-1 KEY SETS  
(5-DOOR)

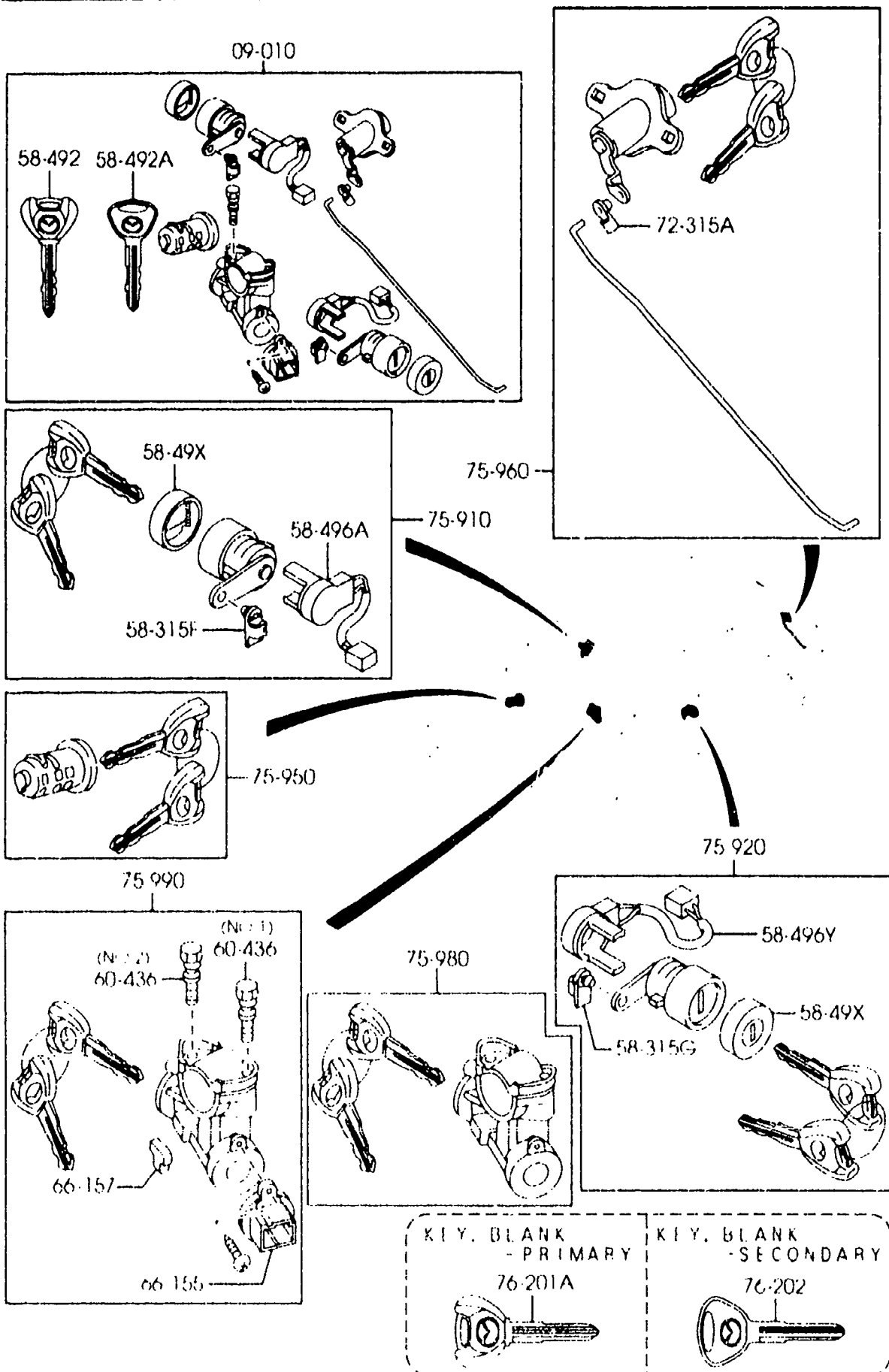

PART NO.	QTY	MODEL/RESTRICTION	MODEL/RESTRICTION	MODEL/RESTRICTION	FROM-TO
09-010		KEY SET	JEU DE BARILLET		
BN5V-09-010	1	(MT)	(B.V.MANU)		
BN6C-09-010	1	(AT)	(B.V.AUTOM)		
58-315F		CLIP(R), LOCK	ATTACHE		
B001-58-315A	1				
58-315G		CLIP(L), LOCK	ATTACHE		
B001-59-315	1				
58-49X		CAP, KEY CYLINDER	CAPUCHON CLAVETTE CY		
B25D-58-49X	2	STEEL	LINDR STEEL		
58-492		KEY, PRIMARY	CLEF, PRIMAIRE		
GD7B-58-492A	1	KEY NO. IS REQUIRED	KEY NO. IS REQUIRED		
58-492A		KEY, SECONDARY	CLE DE RESERVE		
GD7B-58-493	1	KEY NO. IS REQUIRED	KEY NO. IS REQUIRED		
58-496A		SWITCH(R), LOCK-CYLINDER	INTERRUPT. (D), VERROU		
BJ0E-58-498	1		-CYL.		
58-496Y		SWITCH(L), LOCK-CYLINDER	INTERRUPT. (G), VERROU		
BJ0E-59-498	1		-CYL.		
60-436		BOLT, SET	BOULON, JEU		
H043-66-154	1	(ILLUST. NO.1)			
KA01-66-154	1	(ILLUST. NO.2)			
66-155		SWITCH, IGNITION	CONTACT D'ALLUMAGE		
LC70-66-151	1				
66-157		SWITCH, KEY LESS-IG.S	INTERRUPT., KEY LESS-		
GE4T-66-157	1	WITC'	IN.CO		
72-315A		CLIP	CLIP		
S058-62-492	1				

AUBA09

(2B64950)

CAT. AUBA09-02

2001-07

0900AA KEY SETS  
(5-DOOR)

0900AA-2 \* KEY SETS  
(5-DOOR)

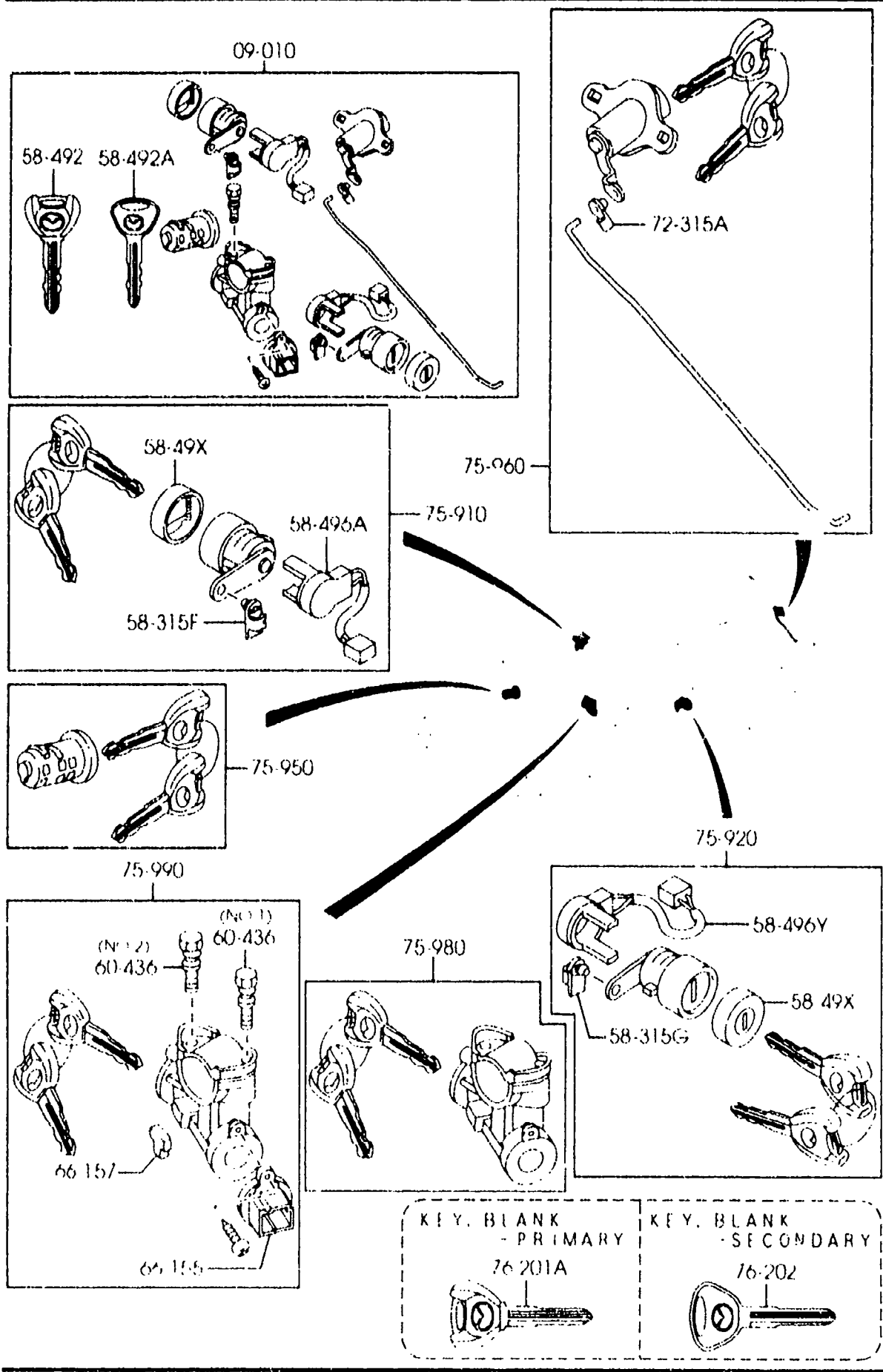

PART NO.	QTY	MODEL/RESTRICTION	MODEL/RESTRICTION	MODEL/RESTRICTION	FROM-TO
75-910 BJYE-76-210B	1	KEY SUB SET(R), DOOR	JEU DE BARILLET (D), PORTE		
75-920 BJYE-76-220B	1	KEY SUB SET(L), DOOR	JEU DE BARILLET (G), PORTE		
75-950 BGIN-76-250B	1	KEY SUB SET, GLOVE	JEU DE BARILLET, BOI TE A GANTS		
75-960 BZYH-76-260	1	KEY SUB SET, LIFT GAT E	JEU DE BARILLET, PORT E DE HAYON		
75-980 BJYE-76-140 GEYM-76-140	1 (MT) 1 (AT)	KEY SUB SET, IG. SWICH	SOUS-JEU, (B.V. MANU) (B.V. AUTOM)		
75-990 BLYD-76-290 GGYB-76-290	1 (MT) 1 (AT)	KEY SUB SET, ST. LOCK	SOUS-JEU, (B.V. MANU) (B.V. AUTOM)		
76-201A GD7B-76-201A	1	KEY, BLANK-PRIMARY	CLE, PLEIN-PRIMAIRE		
76-202 GD7B-76-202	1	KEY, BLANK-SECONDARY	CLE, PLEIN-SCONDAIRE		

AUBA09

(2B64950)

CAT. AUBA09-02

2001-07

(SPORT SUSP)

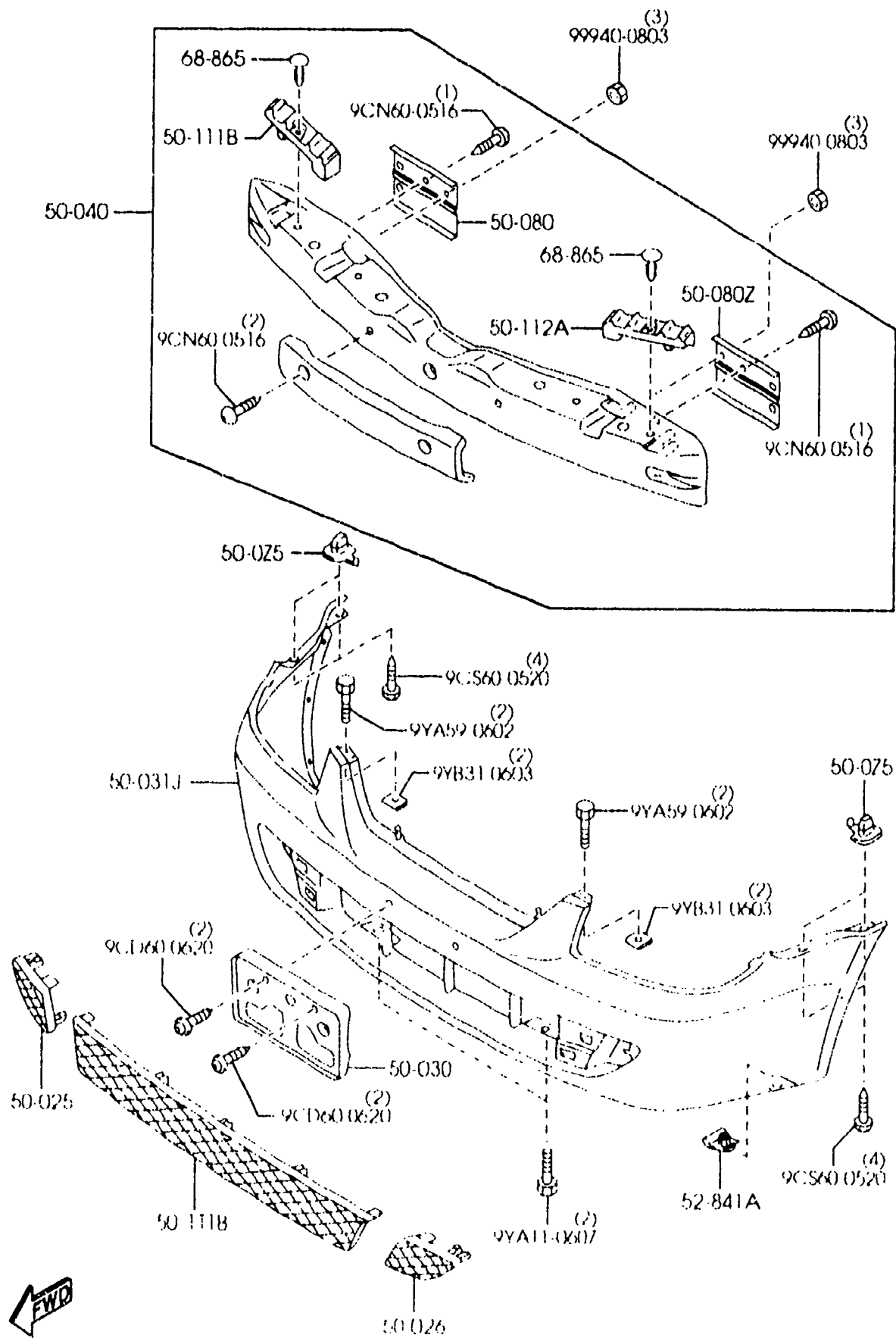

AUBA09

(2B64961)

(MPS SUSP)

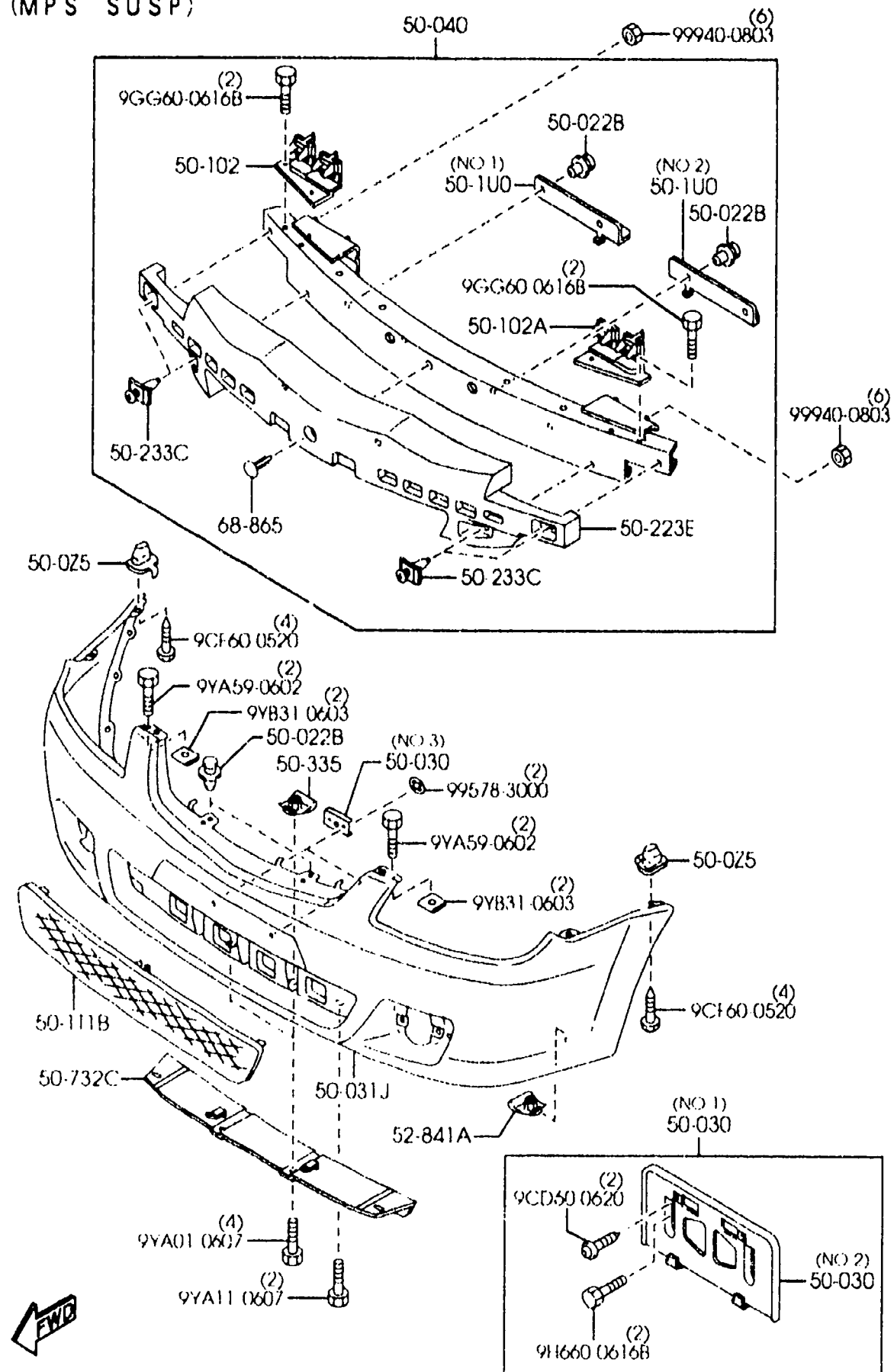

AUBA09

(2B64962)

5000A FRONT BUMPER  
(4-DOOR)

(1/2)

(SPORT SUSP)

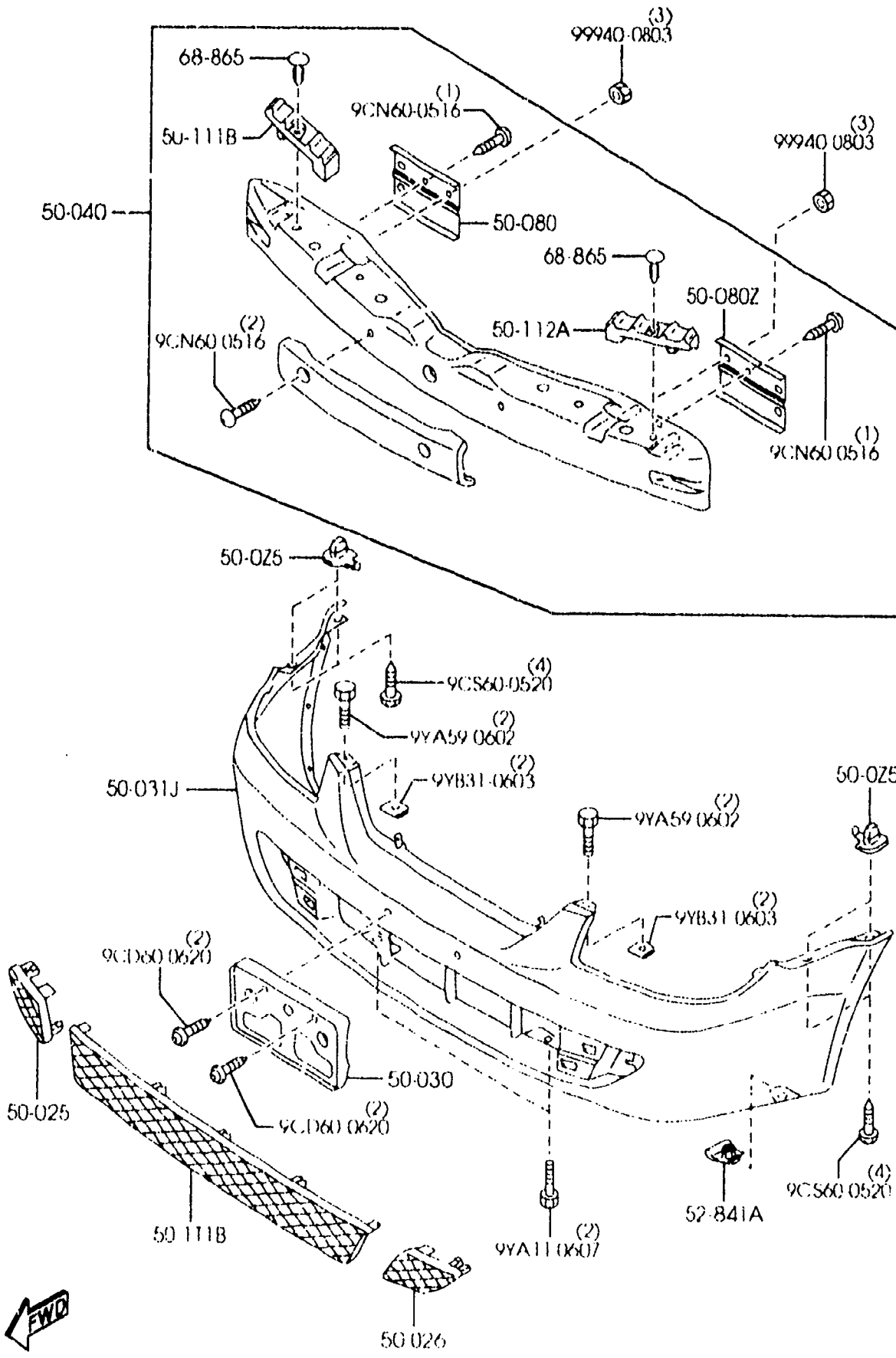

5000A -1 FRONT BUMPER  
(4-DOOR)

PART NO.	QTY	MODEL/RESTRICTION	MODEL/RESTRICTION	MODEL/RESTRICTION	FROM-TO
50-025		GROMMET, SCREW	PROTECTEUR, VIS		
B30D-50-025	4				
50-022B		FASTENER	AGRAFE		
GD7A-50-EA1	6	(MPS SUSP)	(SUSP. MPS)		
50-025		COVER(R), LAMP	COUVERCLE LAMPE(D)		
BL8D-50-C11A	1	(W/O FOG LAMP) (SPORT SUSP)	(SUSP. SPORTIVE)		
50-026		COVER(L), LAMP	COUVERCLE LAMPE(G)		
BL8D-50-C21A	1	(W/O FOG LAMP) (SPORT SUSP)	(SUSP. SPORTIVE)		
50-030		HOLDER, LICENSE PLATE	SUPPORT PLAQUE		
LC62-50-170C	1	(ILLUST. NO.1) (MPS SUSP)	(SUSP. MPS)		
BL8D-50-171	1	(SPORT SUSP)	(SUSP. SPORTIVE)		
C104-50-171B	1	(ILLUST. NO.2) (MPS SUSP)	(SUSP. MPS)		
J001-50-171	2	(ILLUST. NO.3) (MPS SUSP)	(SUSP. MPS)		
50-031J		BUMPER, FRONT	AMORTISSEUR, AVANT		
BL8D-50-031B	1	(SPORT SUSP)	(SUSP. SPORTIVE)		
AA	EXT-	A3D A3E HZ 16W 18J 20P 22A 22K 22L 22V 23F 23G 24A 4F PRIMER (PAINT TO MAT	A3D A3E HZ 16W 18J 20P 22A 22K 22L 22V 23F 23G 24A 4F APPRET(PEINTURE COOR		
BN7H-50-031	1	(MPS SUSP)	(SUSP. MPS)		
AA	EXT-	A3D A3E HZ 16W 18J 20P 22A 22K 22L 22V 23F 23G 24A 4F 22R 24G 24X 26H PRIMER (PAINT TO MAT	A3D A3E HZ 16W 18J 20P 22A 22K 22L 22V 23F 23G 24A 4F 22R 24G 24X 26H APPRET(PEINTURE COOR		
50-040		REINF, BUMPER-FRONT	RENFORT, PARE-CHOCS		
BL8D-50-070B	1	(SPORT SUSP)	(SUSP. SPORTIVE)		
BN7H-50-070	1	(MPS SUSP)	(SUSP. MPS)		-1226
A (BN7H-50-070A)					
BN7H-50-070A	1	(MPS SUSP)	(SUSP. MPS)		1226-
50-080		STAY(R), FRONT BUMPER	FERRURE(D), PARE-CHOC		
BJ0J-50-081	1	(SPORT SUSP)	S A (SUSP. SPORTIVE)		
1226 BJ22* -439334					

AUBA09

(2B64961)

CAT. AUBA09-02

2001-07



5000A FRONT BUMPER  
(4-DOOR)

(2/2)

(MPS SUSP)

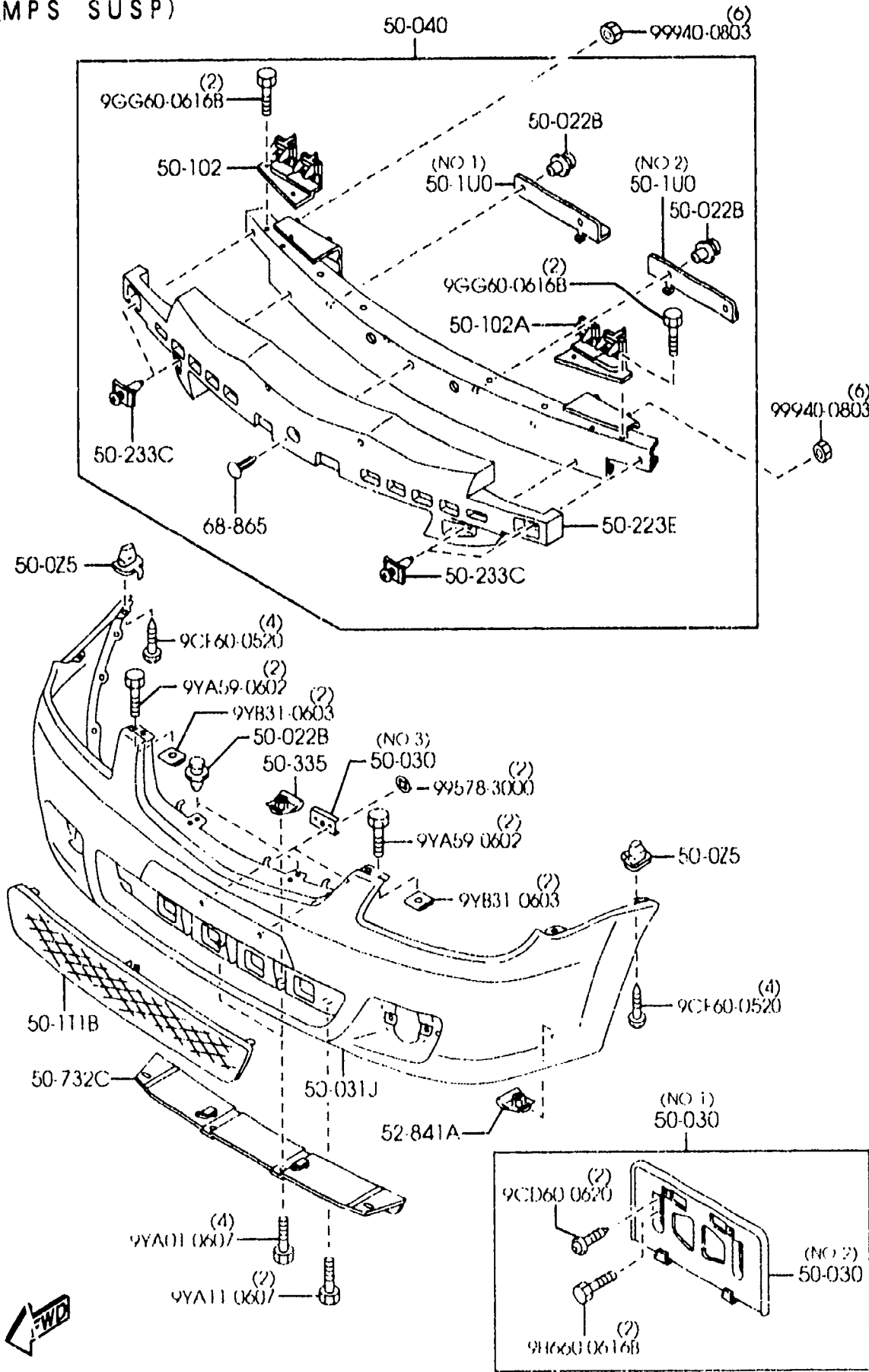

5000A -2 FRONT BUMPER  
(4-DOOR)

PART NO.	QTY	MODEL/RESTRICTION	MODEL/RESTRICTION	MODEL/RESTRICTION	FROM-TO
50-080Z		STAY(L), FRONT BUMPER	FERRURE		
BJ0J-50-091	1	(SPORT SUSP)	(SUSP. SPORTIVE)		
50-1T1B		MESH, FRONT BUMPER	MAILLE, AMORTISSEUR A V		
BL8D-50-1T1A	1	(SPORT SUSP)	(SUSP. SPORTIVE)		
B30P-50-1T1A	1	(MPS SUSP)	(SUSP.MPS)		
50-1U0		PLATE, SEAL	PLAQUE D'ETANCHEITE		
BN5V-50-1U1	1	(ILLUST. NO.1) (MPS SUSP)	(SUSP.MPS)		
BN5V-50-1U2	1	(ILLUST. NO.2) (MPS SUSP)	(SUSP.MPS)		
50-102		SPACER	RONDELLE		
BN5V-50-CS1 A (BN5V-50-CS1A)	1	(MPS SUSP)	(SUSP.MPS)		-1226
BN5V-50-CS1A	1	(MPS SUSP)	(SUSP.MPS)		1226-
50-102A		SPACER	RONDELLE		
BN5V-50-CS0 A (BN5V-50-CS0A)	1	(MPS SUSP)	(SUSP.MPS)		-1226
BN5V-50-CS0A	1	(MPS SUSP)	(SUSP.MPS)		1226-
50-111B		FOAM(R), ENGY. ABS-FRT BUMP	MOUS(D), ABS ENGY, P-C HC AV		
BL8D-50-111	1	(SPORT SUSP)	(SUSP. SPORTIVE)		
50-112A		FOAM(L), ENGY. ABS-FRT BUMP	MOUS(G), ABS ENGY, P-C HC AV		
BL8D-50-112	1	(SPORT SUSP)	(SUSP. SPORTIVE)		
50-223E		FOAM, BUMPER-FRONT	MOUS, AMORT-AV.		
BN5V-50-111	1	(MPS SUSP)	(SUSP.MPS)		
50-233C		FASTENER, REAR BUMPER	FERMETURE, PARE-CHOC AR		
BF82-50-233	4	(MPS SUSP)	(SUSP.MPS)		
50-335		NUT, CLIP	ECROU, CLIP		
FB01-50-133C	4	(MPS SUSP)	(SUSP.MPS)		
50-732C		SKIRT, FRONT AIR DAM	JUPE, BARRAGE AIR AVA NT		
B30P-51-9K1B	1	(MPS SUSP)	(SUSP.MPS)		

1226 BJ22\* -439334

AUBA09

(2B64962)

CAT. AUBA09-02

2001-07

5000A FRONT BUMPER  
(4-DOOR)

(1/2)

(SPORT SUSP)

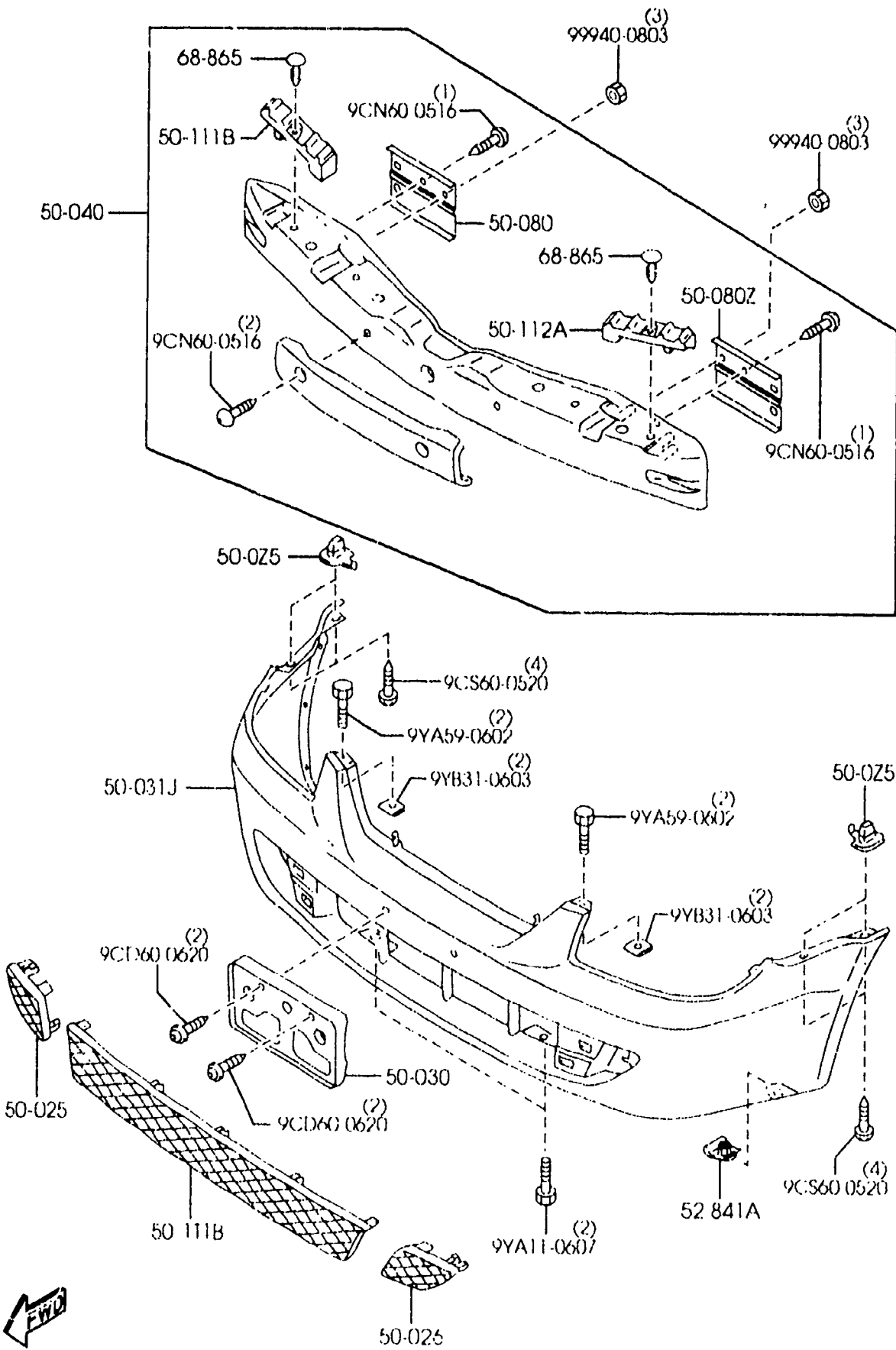

5000A -3 \* FRONT BUMPER  
(4-DOOR)

PART NO.	QTY	MODEL/RESTRICTION	MODEL/RESTRICTION	MODEL/RESTRICTION	FROM-TO
52-841A		NUT,CLIP	ECROU		
B455-56-135	6				
68-865		FASTENER	AGRAFE		
G045-68-865	1	(MPS SUSP)	(SUSP.MPS)		
00	INT-	BN1 BN2 BN3 BN4 BLACK	BN1 BN2 BN3 BN4 NOIR		
G045-68-865	2	(SPORT SUSP)	(SUSP. SPORTIVE)		
00	INT-	BN1 BN2 BN3 BN4 BLACK	BN1 BN2 BN3 BN4 NOIR		

AUBA09

(2B64961)

CAT. AUBA09-02

2001-07

3-K 3

5000AA FRONT BUMPER  
(5-DOOR)

5000AA-1 FRONT BUMPER  
(5-DOOR)

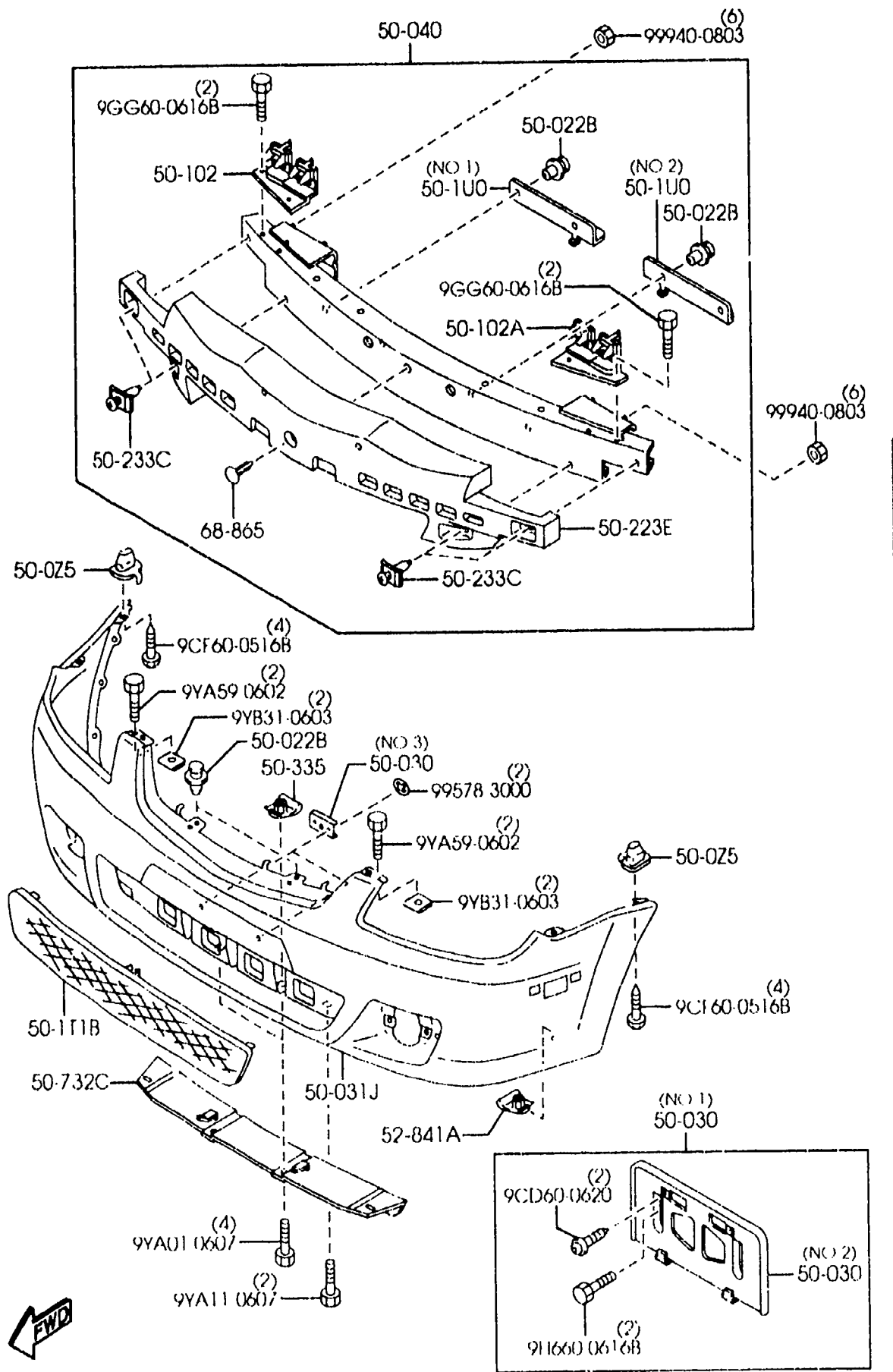

PART NO.	QTY	MODEL/RESTRICTION	MODEL/RESTRICTION	MODEL/RESTRICTION	FROM-TO
50-025		GROMMET, SCREW	PROTECTEUR, VIS		
B30D-50-025	4				
50-022B		FASTENER	AGRAFE		
GD7A-50-EA1	6				
50-030		HOLDER, LICENSE PLATE	SUPPORT PLAQUE		
LC62-50-170C	1	(ILLUST. NO.1)			
C104-50-171B	1	(ILLUST. NO.2)			
J001-50-171	2	(ILLUST. NO.3)			
50-031J		BUMPER, FRONT	AMORTISSEUR, AVANT		
BN5V-50-031B	1				
AA	EXT-	A3D A3E HZ 16W 18J 20P 22A 22K 22L 22V 23F 23G 24A 4F PRIMER (PAINT TO MAT	A3D A3E HZ 16W 18J 20P 22A 22K 22L 22V 23F 23G 24A 4F APPRET (PEINTURE COOR		
50-040		REINF, BUMPER-FRONT	RENFORT, PARE-CHOC		
BN7H-50-070A	1				
50-1T1B		MESH, FRONT BUMPER	MAILLE, AMORTISSEUR A V		
B30P-50-1T1A	1				
50-1U0		PLATE, SEAL	PLAQUE D'ETANCHEITE		
BN5V-50-1U1	1	(ILLUST. NO.1)			
BN5V-50-1U2	1	(ILLUST. NO.2)			
50-102		SPACER	RONDELLE		
BN5V-50-CS1A	1				
50-102A		SPACER	RONDELLE		
BN5V-50-CS0A	1				
50-223E		FOAM, BUMPER-FRONT	MOUS, AMORT-AV.		
BN5V-50-111	1				
50-233C		FASTENER, REAR BUMPER	FERMETURE, PARE-CHOC AR		
BF82-50-233	4				
50-335		NUT, CLIP	ECROU, CLIP		

AUBA09

(2B64970)

CAT. AUBA09-02

2001-07

5000AA FRONT BUMPER  
(5-DOOR)

5000AA-2 \* FRNT BUMPER  
(5-DOOR)

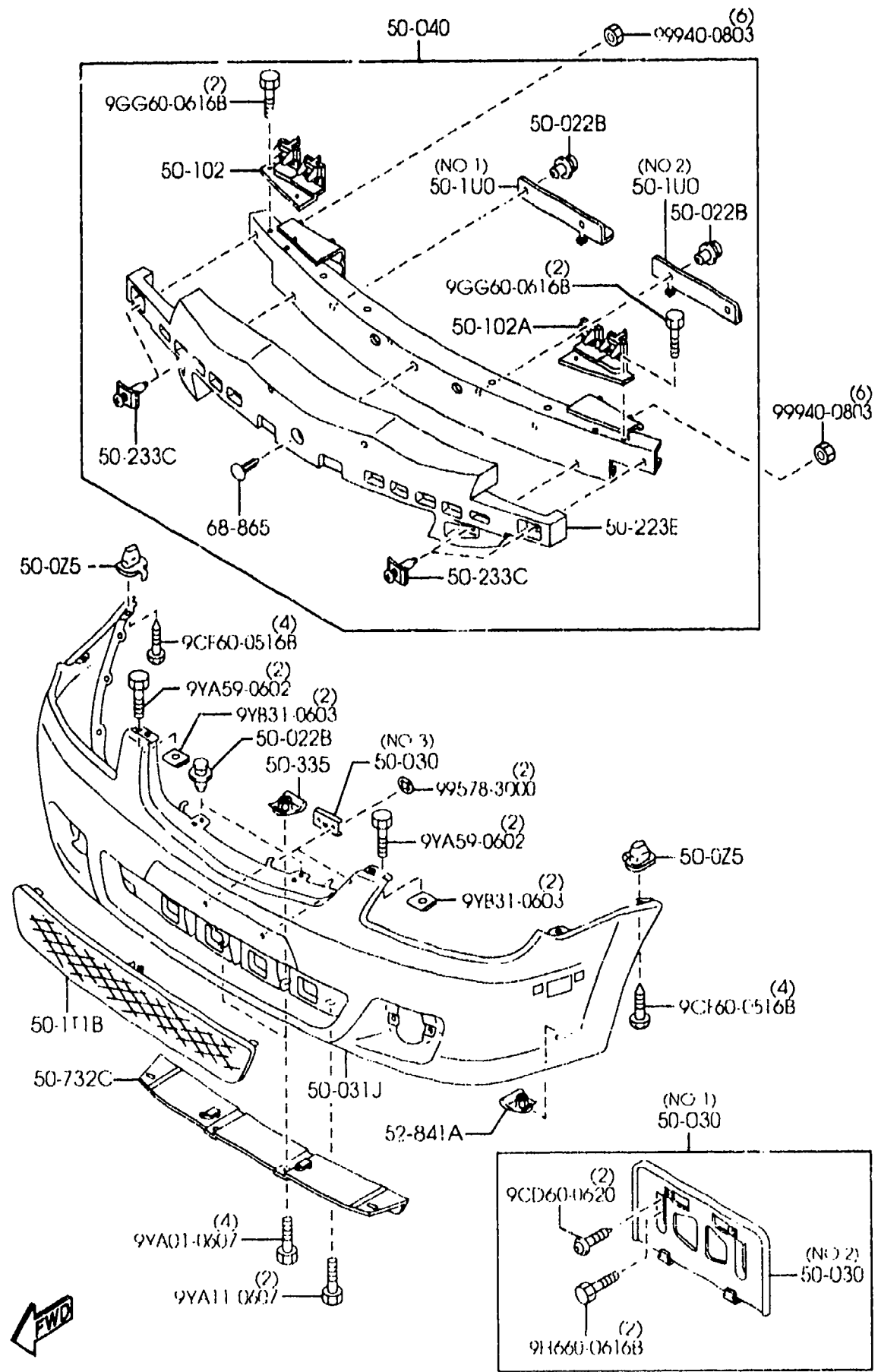

PART NO	QTY	MODEL, RESTRICTION	MODEL/RESTRICTION	MODEL/RESTRICTION	FROM-TO
CONT'D FB01-50-133C	4				
50-732C		SKIRT, FRONT AIR DAM	JUPE, BARRAGE AIR AVANT		
B30P-51-9K1B	1				
52-841A		NUT, CLIP	ECROU		
B455-56-135	6				
68-865		FASTENER	AGRAFE		
G045-68-865	1				
00	INT-	BN4 BN1 BN2 BN3 BLACK	BN4 BN1 BN2 BN3 NOIR		

AUBA09

(2B64970)

CAT. AUBA09-02

2001-07

(SPORT SUSP)

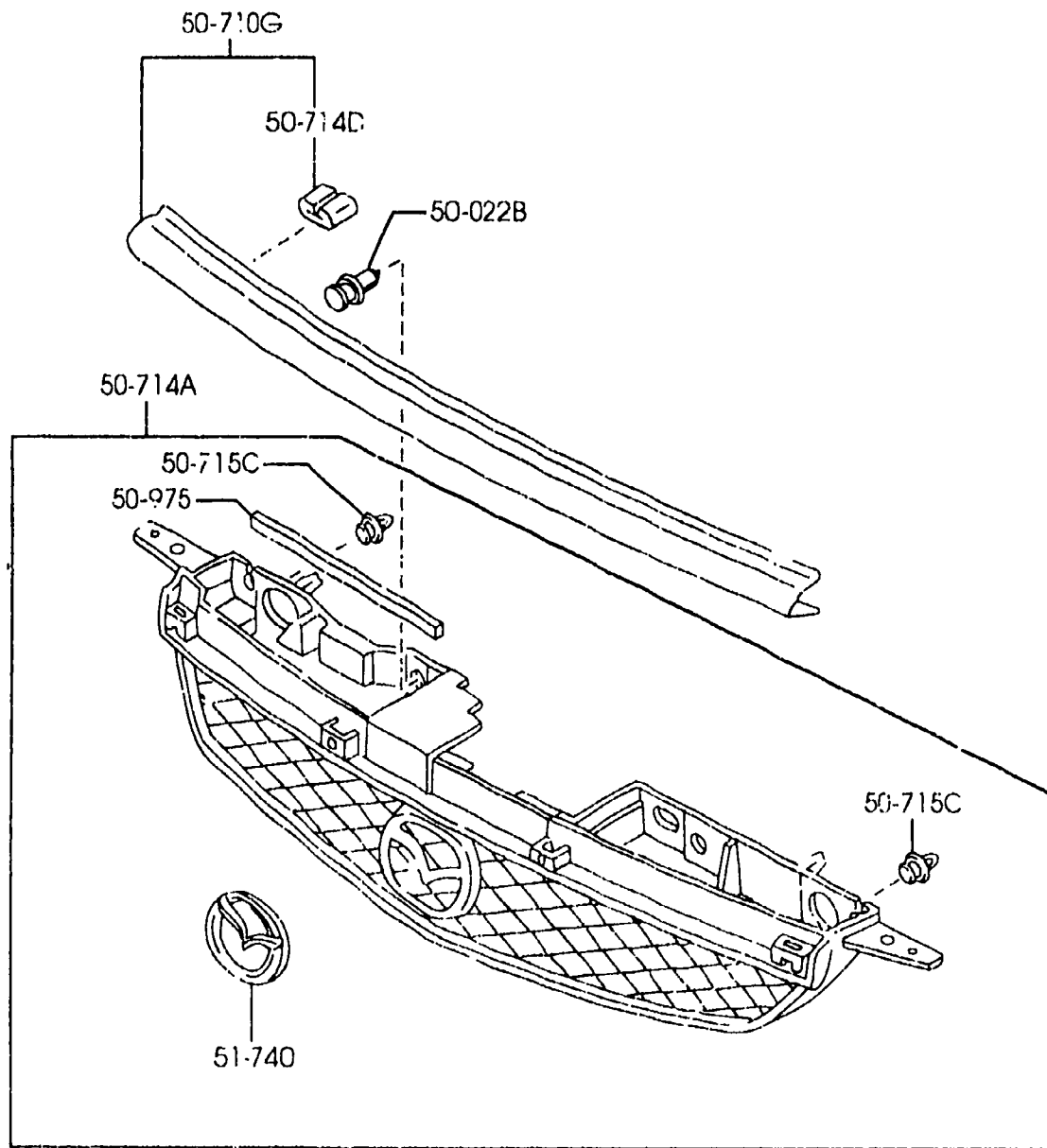

(MPS SUSP)

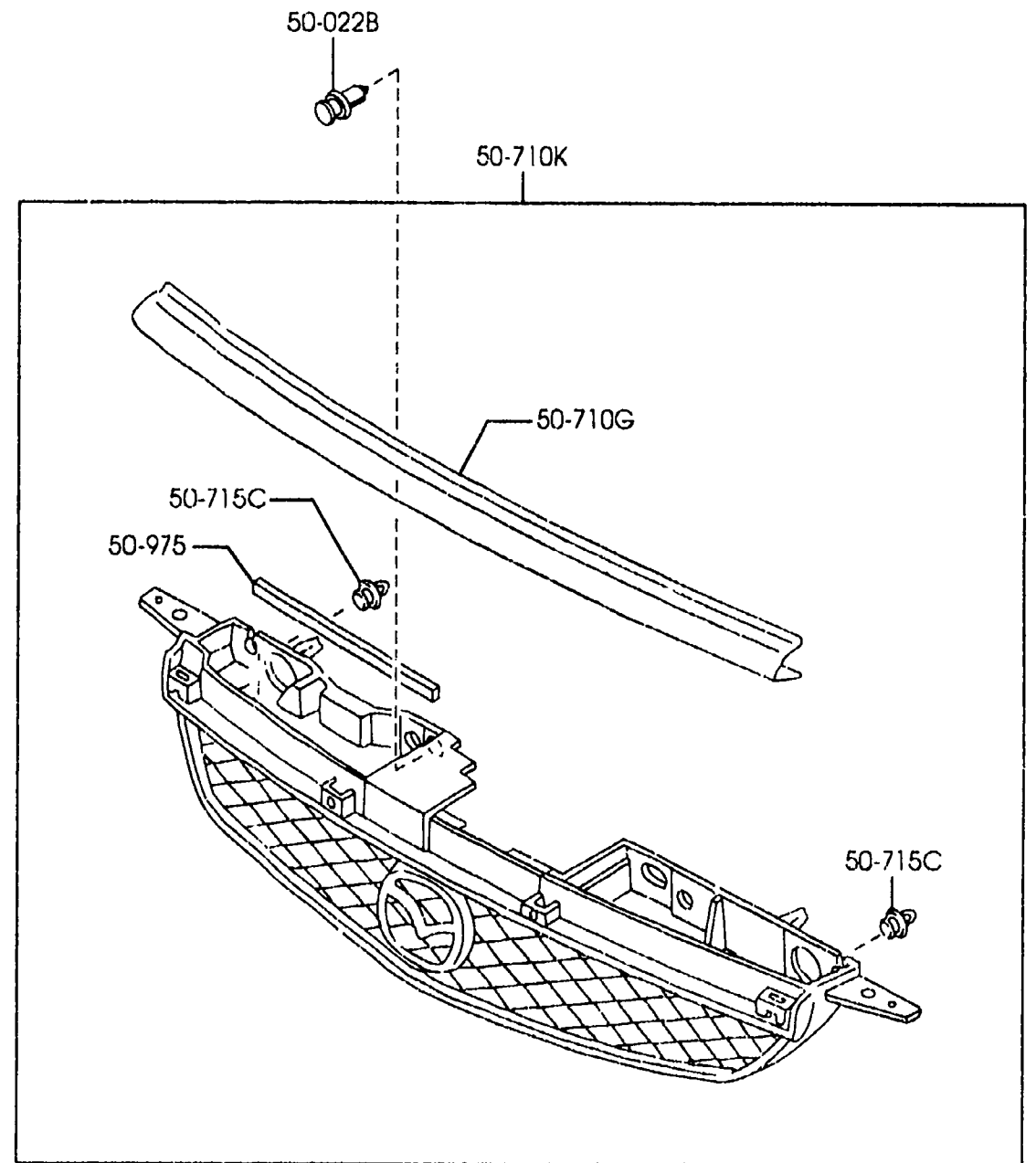

(SPORT SUSP)

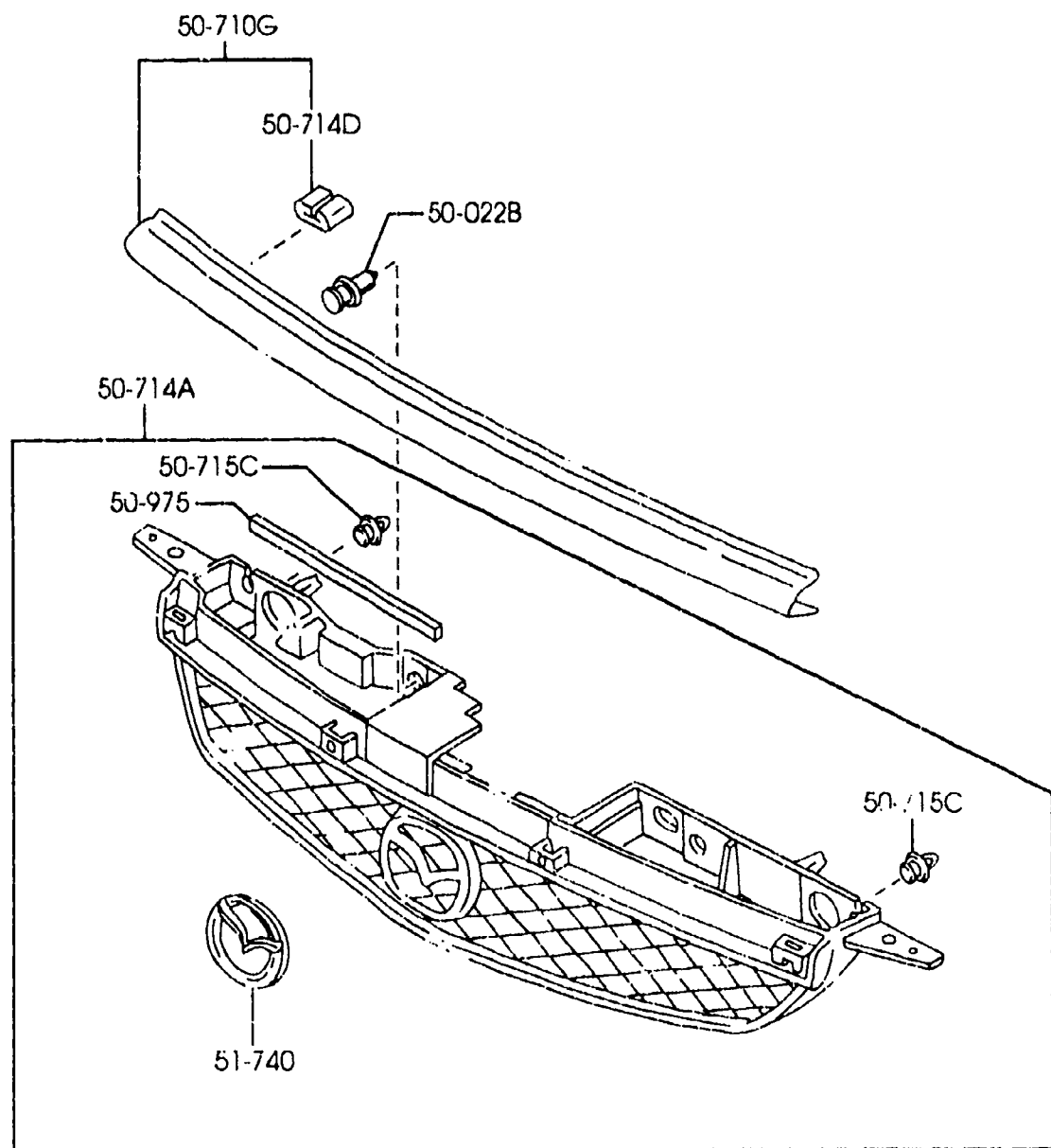

PART NO.	QTY	MODEL/RESTRICTION	MODEL/RESTRICTION	MODEL/RESTRICTION	FROM-TO
50-022B		FASTENER	AGRAFE		
GD7A-50-EA1	2				
50-710G		GRILLE, RADIATOR-UPP.	GRILLE SUP., CALANDRE		
BL8D-50-710	1	(STD GRILLE, W/BLACK BAR) (SPORT SUSP)	(SUSP. SPORTIVE)		
B30D-50-710	1	(STD GRILLE, W/O BLACK BAR) (SPORT SUSP)	(SUSP. SPORTIVE)		
B30P-50-711	1	(MPS SUSP)	(SUSP. MPS)		
50-710K		GRILLE, RADIATOR	GRILLE RADIATEUR		
BN7H-50-710A	1	(MPS SUSP)	(SUSP. MPS)		
50-714A		REINF., RADIATOR GRILLE	RENFORT, GRILLE RADIATEUR		
BL8D-50-71Y	1	(SPORT SUSP)	(SUSP. SPORTIVE)		
50-714D		GASKET, RADIATOR GRILLE	JOINT, GRILLE RADIATEUR		
B30D-50-7M3	1	(SPORT SUSP)	(SUSP. SPORTIVE)		
50-715C		CLIP	ATTACHE		
B25F-50-714	2				
50-975		GASKET	JOINT		
B25D-50-7M3	1				
51-740		MASCOT, FRONT	MASCOTTE AV		
S41A-51-731A	1	(SPORT SUSP)	(SUSP. SPORTIVE)		



5005AA RADIATOR GRILLE  
(5-DOOR)

5005AA-1 \* RADIATOR GRILLE  
(5-DOOR)

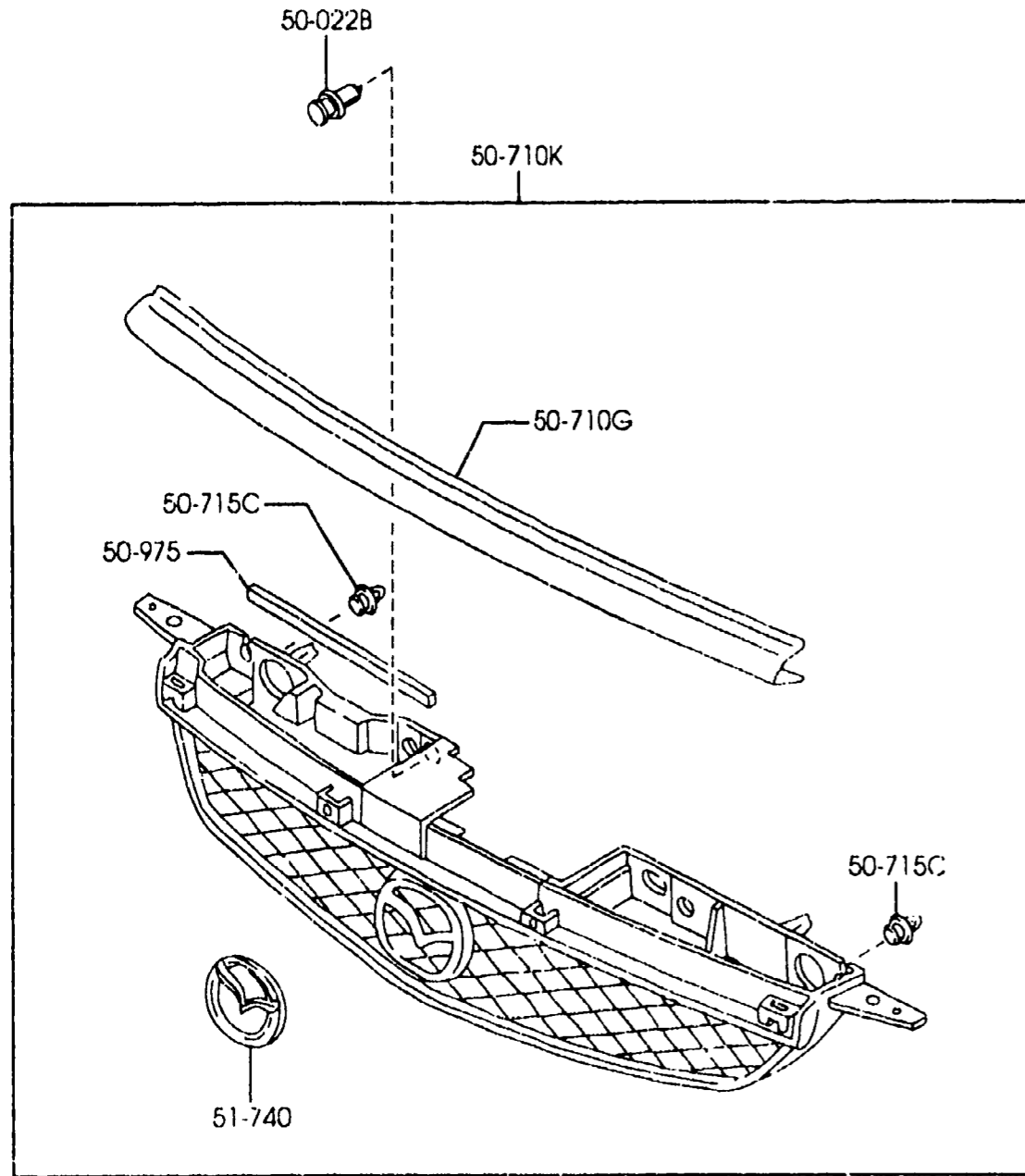

PART NO.	QTY	MODEL/RESTRICTION	MODEL/RESTRICTION	MODEL/RESTRICTION	FROM-TO
50-022B GD7A-50-EA1	4	FASTENER	AGRAFE		
50-710G B30P-50-711	1	GRILLE,RADIATOR-UPP.	GRILLE SUP.,CALANDRE		
50-710K B30P-50-710	1	GRILLE,RADIATOR	GRILLE RADIATEUR		
50-715C B25F-50-714	2	CLIP	ATTACHE		
50-975 B25D-50-7M3	1	GASKET	JOINT		
51-740 S41A-51-731A	1	MASCOT,FRONT	MASCOTTE AV		



AUBA09

(2B43560)

CAT. AUBA09-02

2001-07





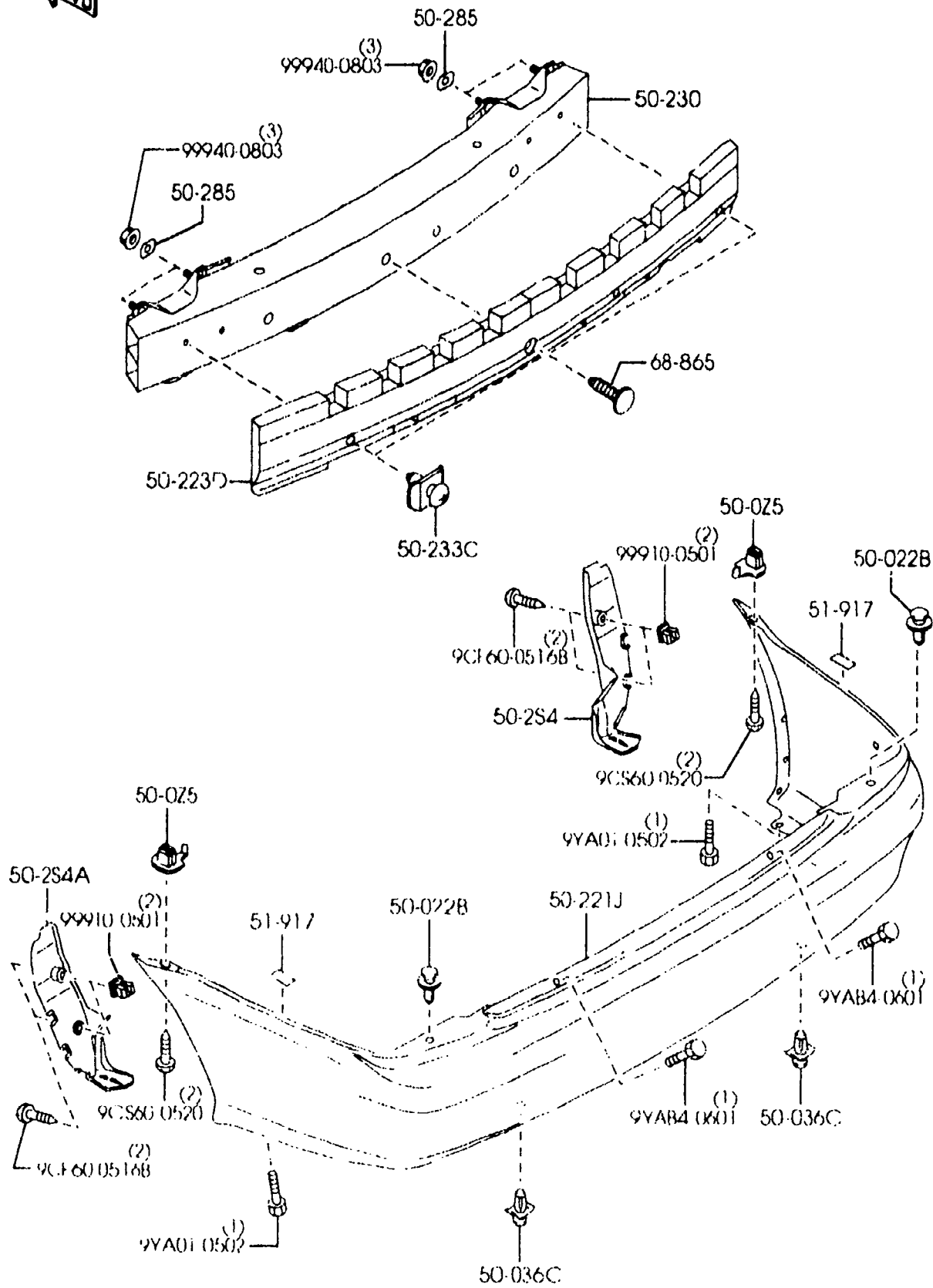

PART NO.	QTY	MODEL/RESTRICTION	MODEL/RESTRICTION	MODEL/RESTRICTION	FROM-TO
CONT'D 0045-68-865	1				
00	INT-	BN1 BN2 BN3 BN4 BLACK	BN1 BN2 BN3 BN4 NOIR		



5010B REAR BUMPER  
(5-DOOR)

5010B -2 \* REAR BUMPER  
(5-DOOR)

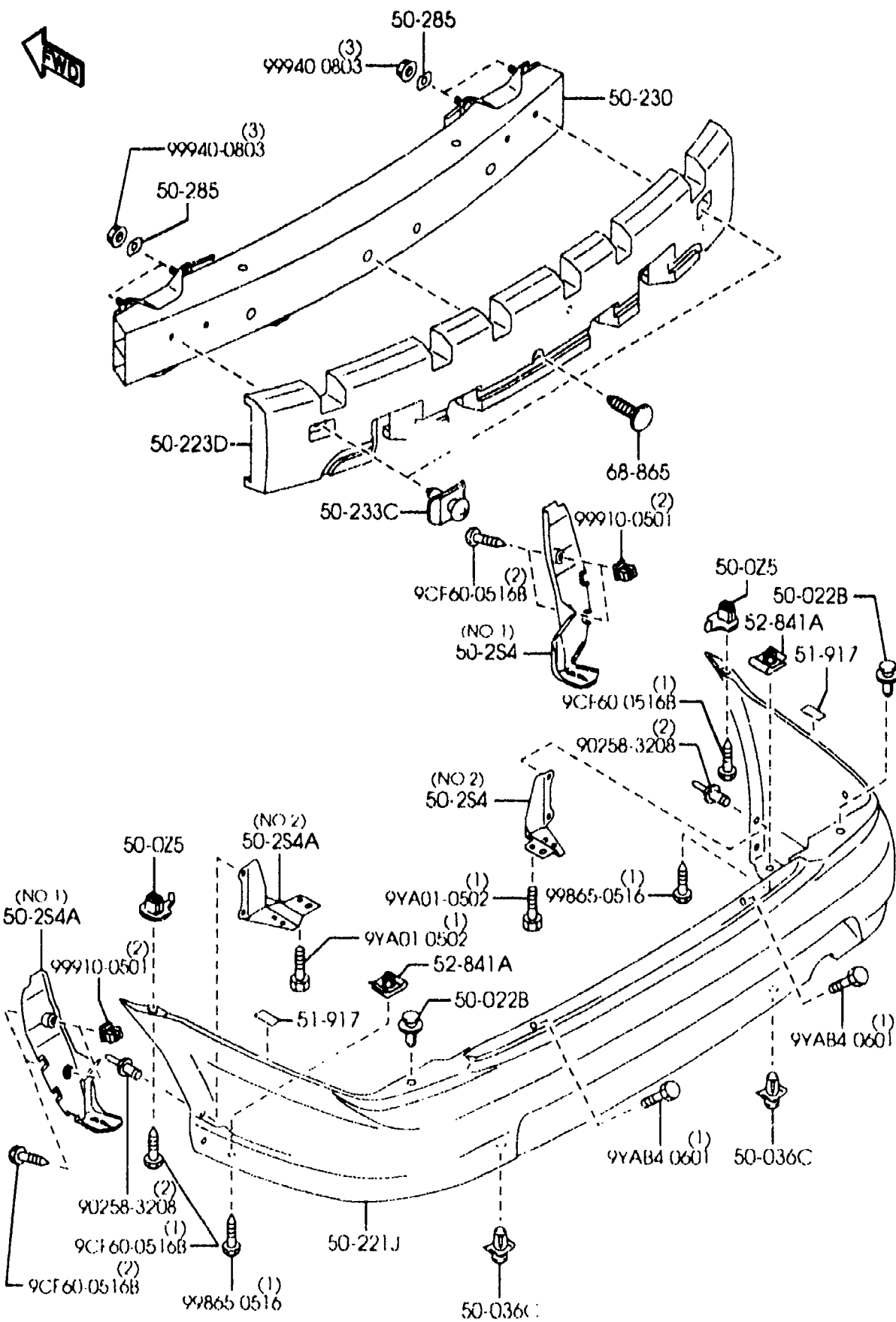

PART NO.	QTY	MODEL/RESTRICTION	MODEL/RESTRICTION	MODEL/RESTRICTION	FROM-TO
68-865		FASTENER	AGRAFE		
G045-68-865	1				
00	INT-	BN4 BN1 BN2 BN3 BLACK	BN4 BN1 BN2 BN3 NOIR		

AUBA09

(2B56850)

CAT. AUBA09-02

2001-07

5030A WINDOW MOULDINGS  
(4-DOOR)

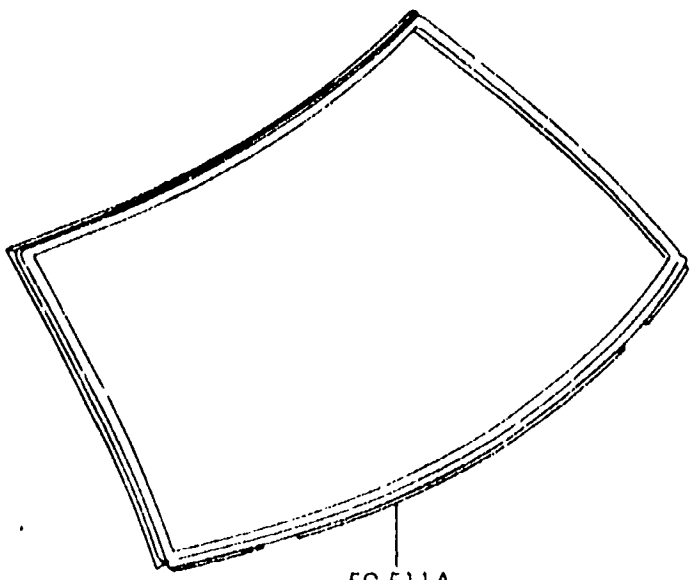
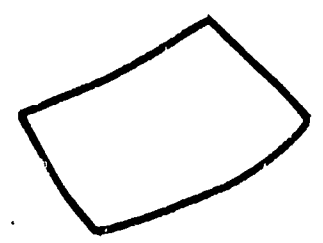
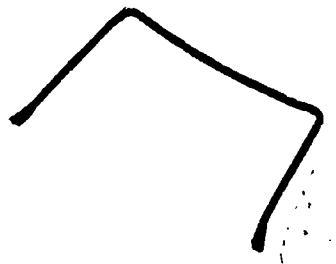
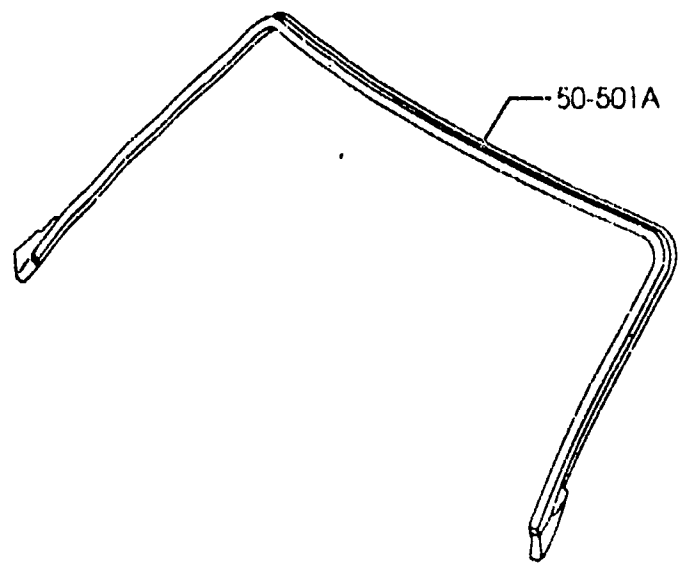

50-511A

5030A -1 \* WINDOW MOULDINGS  
(4-DOOR)

PART NO.	QTY	MODEL/RESTRICTION	MODEL/RESTRICTION	MODEL/RESTRICTION	FROM-TO
+-----+   50-501A   +-----+ B25D-50-601D	1	MOULD,FRT WINDOW-UP	MOULURE SUP.,FENETRE AV		
+-----+   50-511A   +-----+ B25D-50-611A	1	MOULD,UPPER-BACK WIN D	MOULURE SUP.,FENETRE AR		

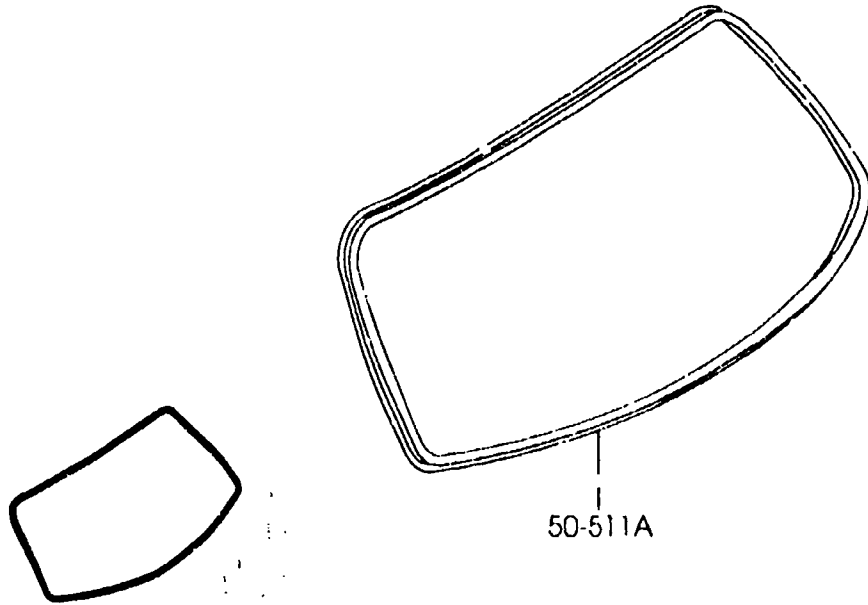
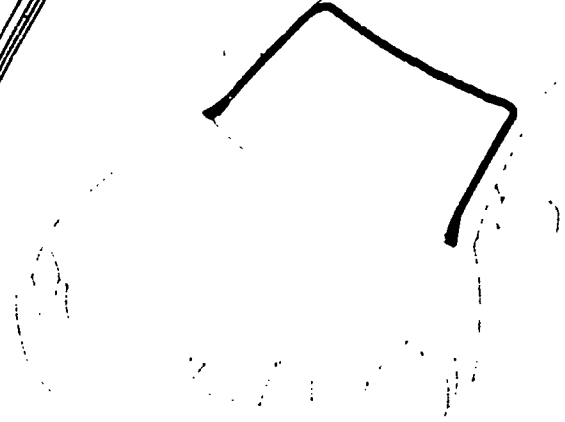
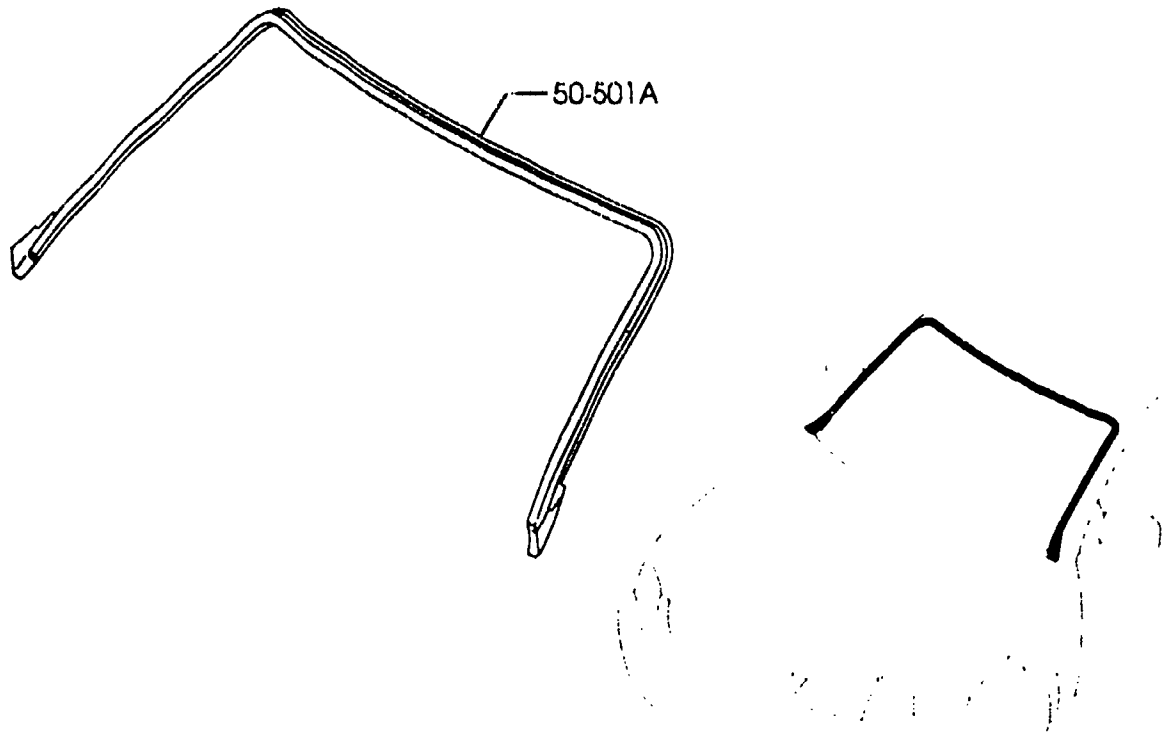

PART NO.	QTY	MODEL/RESTRICTION	MODEL/RESTRICTION	MODEL/RESTRICTION	FROM-TO
+-----+   50-501A   +-----+ B25D-50-601D	1	MOULD,FRT WINDOW-UP	MOULURE SUP.,FENETRE AV		
+-----+   50-511A   +-----+ B25R-50-611A	1	MOULD,UPPER-BACK WIN D	MOULURE SUP.,FENETRE AR		

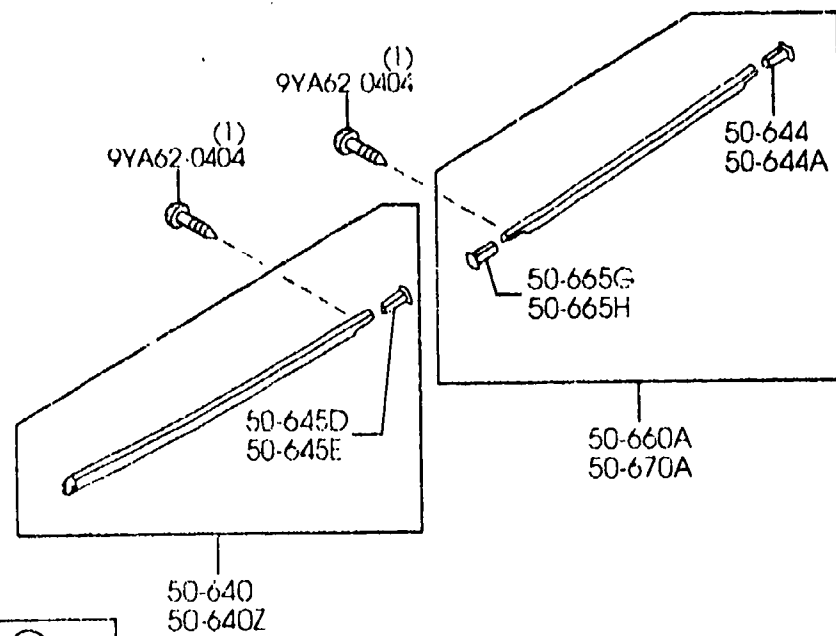
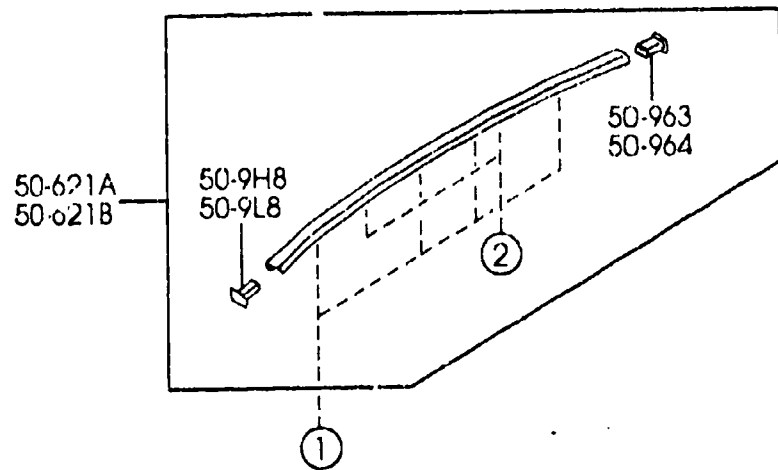

①	②
50-629A	50-911

PART NO.	QTY	MODEL/RESTRICTION	MODEL/RESTRICTION	MODEL/RESTRICTION	FROM-TO
50-621A B25D-50-9H0B	1	MOULD(R), ROOF	MOULE(D), TOIT		
50-621B B25D-50-9L0B	1	MOULD(L), ROOF	MOULE(G), TOIT		
50-629A BCVM-50-629A	8	CLIP	ATTACHE		
50-640 B25D-50-640	1	MOULD(R), FRT. BELT.	MOULURE(D), CEINTURE AV		
50-640Z B25D-50-650	1	MOULD(L), FRT. BELT.	MOULURE(G), CEINTURE AV		
50-644 B25D-50-665	1	PROTECTOR'A'(R), BELT LINE	PROTECTEUR'A'(D), CEINTURE		
50-644A B25D-50-675	1	PROTECTOR'A'(L), BELT LINE	PROTECTEUR'A'(G), CEINTURE		
50-645D B25D-50-645	1	PROTECTOR(R), MOULD-BELT LINE	PROTECTEUR(D), MOUL-BELT LINE		
50-645E B25D-50-655	1	PROTECTOR(L), MOULD-BELT LINE	PROTECTEUR(G), MOUL-BELT LINE		
50-660A B25D-50-660A	1	MOULD(R), RR. BELTLINE	MOULURE(D),		
50-665G B25D-50-664	1	PROTECTOR(R), MOULD-BELT LINE	PROTECTEUR(D), MOUL-BELT LINE		
50-665H B25D-50-674	1	PROTECTOR(L), MOULD-BELT LINE	PROTECTEUR(G), MOUL-BELT LINE		
50-670A B25D-50-670A	1	MOULD(L), RR. BELTLINE	MOULURE(G),		
50-9H8 B25D-50-9H1A	1	PROTECTOR(R), ROOF MOLD	PROTECTEUR(D), MOUL-TOIT		

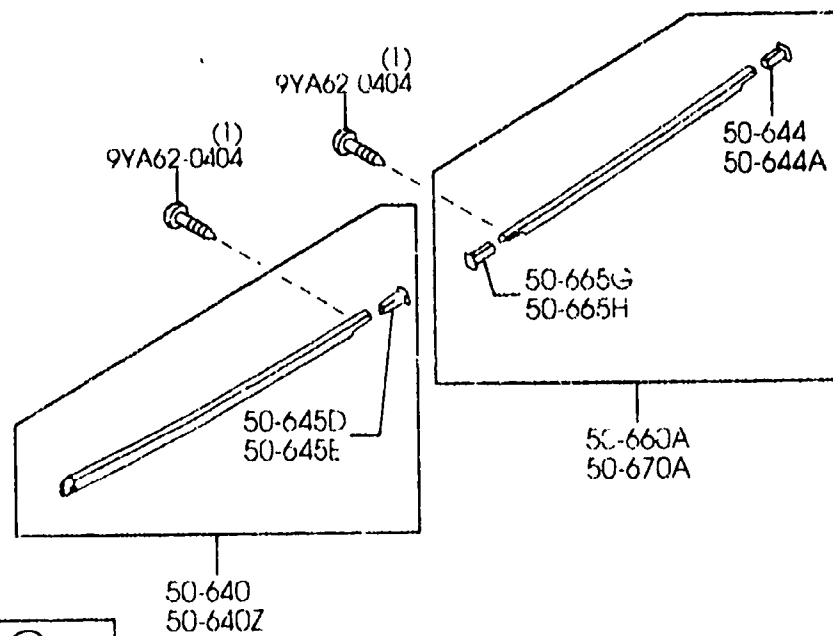
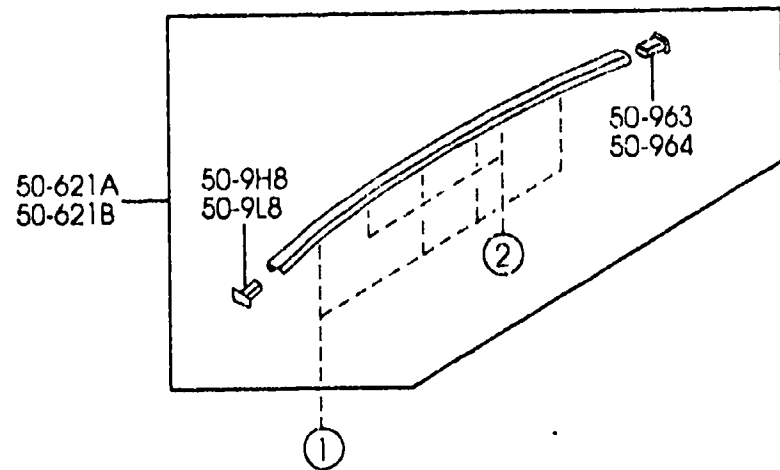

①	②
50-629A	50-911

PART NO.	QTY	MODEL/RESTRICTION	MODEL/RESTRICTION	MODEL/RESTRICTION	FROM-TO
50-9L8 B25D-50-9L1A	1	PROTECTOR(L), ROOF MLD	PROTECTEUR(G), MOUL. TOIT		
50-911 BC1M-50-9H7	4	PROTECTOR	PROTECTEUR		
50-963 B25D-50-9H2A	1	PROTECTOR(R)	PROTECTEUR (D)		
50-964 B25D-50-9L2A	1	PROTECTOR(L)	PROTECTEUR(G)		





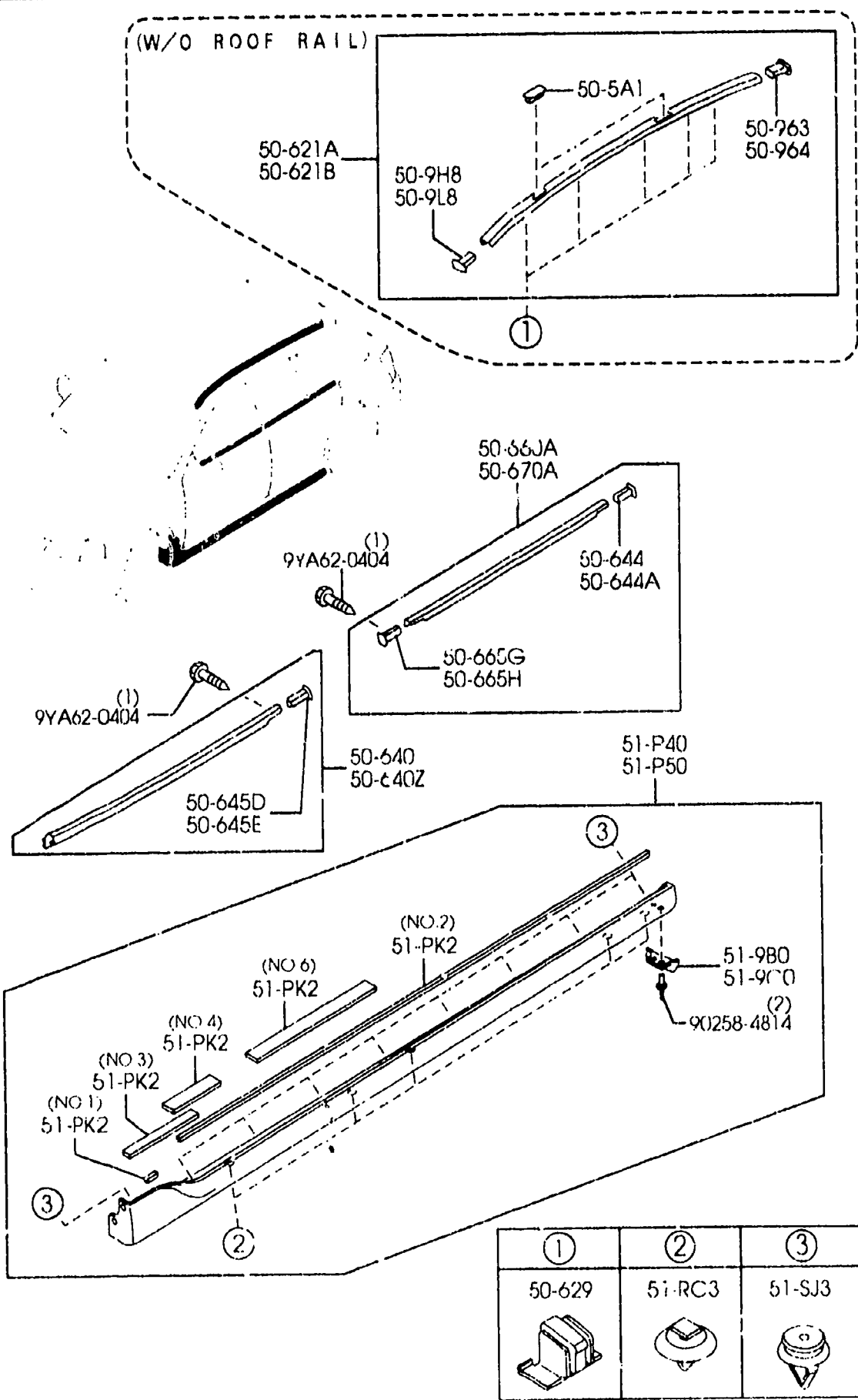

PART NO.	QTY	MODEL/RESTRICTION	MODEL/RESTRICTION	MODEL/RESTRICTION	FROM-TO
50-335		NUT,CLIP	ECROU,CLIP		
BN6B-50-B11	4	(W/ROOF RAIL)	(AVEC GALERIE)		
50-335A		NUT,CLIP	ECROU		
BN5W-50-B11	4	(W/ROOF RAIL)	(AVEC GALERIE)		
50-5A1		CAP,DRIP MOULD	CAPUCHON,MOULAGE GOUTTE		
*BJ3D-50-5A1B	4	(W/O ROOF RAIL)	(SANS GALERIE)		
50-621A		MOULD(R),ROOF	MOULE(D),TOIT		
*BJ3D-50-9H0D	1	(W/O ROOF RAIL)	(SANS GALERIE)		
B25R-50-9H0A	1	(W/ROOF RAIL)	(AVEC GALERIE)		
50-621B		MOULD(L),ROOF	MOULE(O),TOIT		
*BJ3D-50-9L0D	1	(W/O ROOF RAIL)	(SANS GALERIE)		
B25R-50-9L0A	1	(W/ROOF RAIL)	(AVEC GALERIE)		
50-629		CLIP,ROOF MOULD	COLLIER,MOULE TOIT		
G1YS-50-629B	2	(W/ROOF RAIL)	(AVEC GALERIE)		
*G1YS-50-629B	10	(W/O ROOF RAIL)	(SANS GALERIE)		
50-640		MOULD(R),FRT. BELT.	MOULURE(D),CEINTURE AV		
B25D-50-640	1				
50-640Z		MOULD(L),FRT. BELT.	MOULURE(G),CEINTURE AV		
B25D-50-650	1				
50-644		PROTECTOR'A'(R),BELT LINE	PROTECTEUR'A'(D),CEINTURE		
B25D-50-665	1				
50-644A		PROTECTOR'A'(L),BELT LINE	PROTECTEUR'A'(G),CEINTURE		
B25D-50-675	1				
50-645D		PROTECTOR(R),MOULD-BELT LINE	PROTECTEUR(D),MOULURE-BELT LINE		
B25D-50-645	1				
50-645E		PROTECTOR(L),MOULD-BELT LINE	PROTECTEUR(G),MOULURE-BELT LINE		
B25D-50-655	1				
50-660A		MOULD(R),RR. BELTLINE	MOULURE(D),		



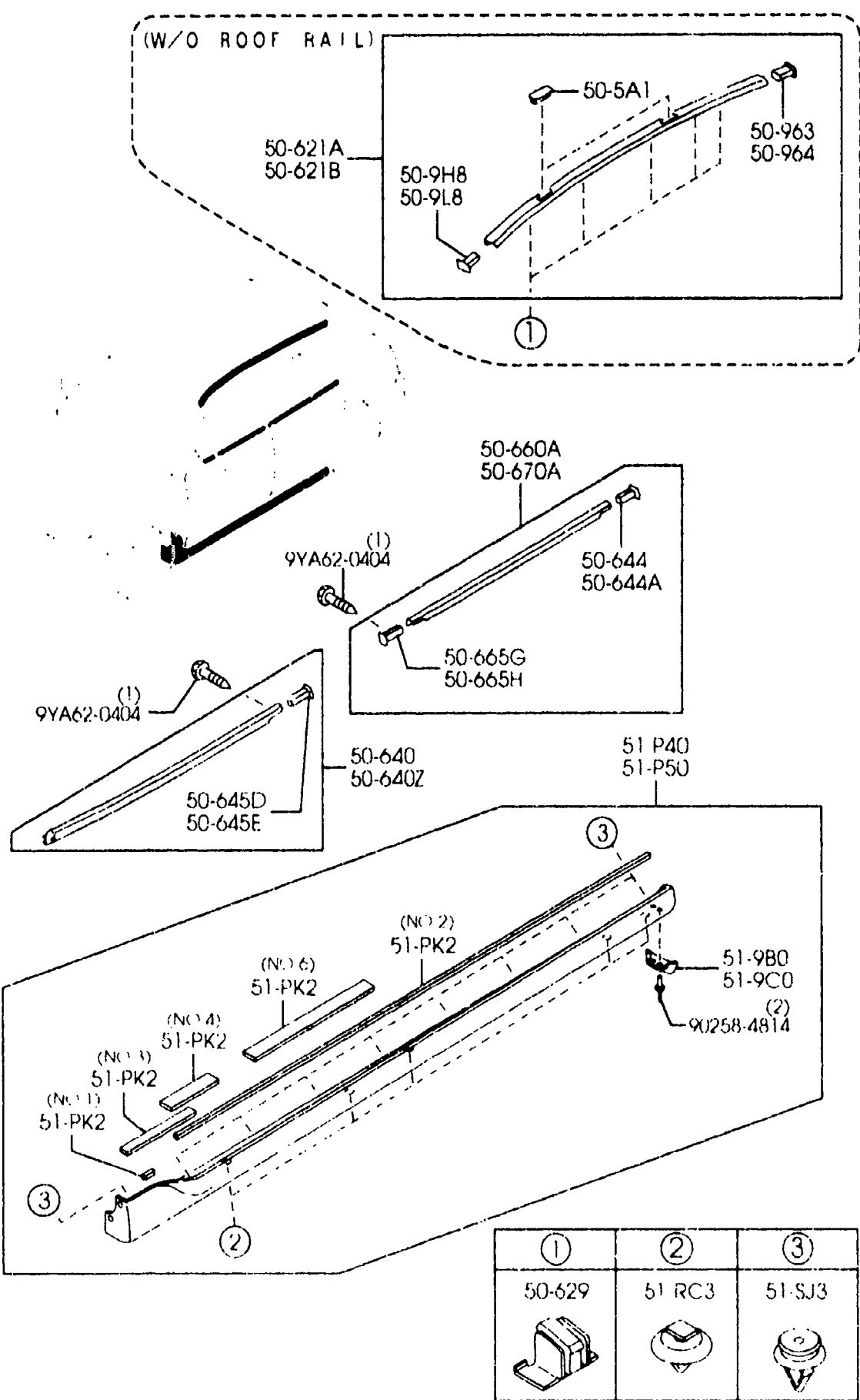

PART NO.	QTY	MODEL/RESTRICTION	MODEL/RESTRICTION	MODEL/RESTRICTION	FROM-TO
<b>CONT'D</b>					
10	EXT-	A3E CLASSIC RED CLE	A3E ROUGE ETERNEL		
46	EXT-	18J GRACE GREEN MC	18J VERT GRACE METALLISE		
50	EXT-	22A SUPREME BLUE MC	22A ROUGE NEUF		
67	EXT-	22V SUNLIGHT SILVER M	22V ARGENT METALL. SOLEIL		
		51-P50	MOULD(L),SIDE STEP	MOULAGE(G),MARCHE LAT.	
BN3V-51-P50C	1				
HZ	EXT-	HZ SUNBURST YELLOW	HZ JAUNE BRULE		
08	EXT-	16W BLACK MC	16W NOIR METALLISE		
09	EXT-	A3D PURE WHITE	A3D BLANC PURE		
10	EXT-	A3E CLASSIC RED CLE	A3E ROUGE ETERNEL		
46	EXT-	18J GRACE GREEN MC	18J VERT GRACE METALLISE		
50	EXT-	22A SUPREME BLUE MC	22A ROUGE NEUF		
67	EXT-	22V SUNLIGHT SILVER M	22V ARGENT METALL. SOLEIL		
		51-RC3	CLIP,SIDE GARNISH	COLLIER,GARNITURE LATERAL	
KA80-51-RE5A	10				
		51-SJ3	CLIP	ATTACHE	
G18K-51-SJ3	18				
		51-T10	RACK(R),ROOF	CROCHET(D),TOIT	
B25H-51-T10C	1	(W/ROOF RAIL)	(AVEC GALERIE)		
		51-T11A	COVER(P),ROOF RACK	COUVERCLE GALERIE(D)	
BN5W-51-5D1	1	(ILLUST. NO.1) (W/ROOF RAIL)	(AVEC GALERIE)		
BN5W-51-5G1	1	(ILLUST. NO.2) (W/ROOF RAIL)	(AVEC GALERIE)		
		51-T12B	CAP(R),FRONT	BOUCHON(D),AVANT	
BN5W-51-T12	1	(ILLUST. NO.1) (W/ROOF RAIL)	(AVEC GALERIE)		
B25H-51-T12B	1	(ILLUST. NO.2) (W/ROOF RAIL)	(AVEC GALERIE)		
		51-T13	PROTECTOR(R),ROOF RACK	PROTECTEUR(D),GALERIE	

(W/ROOF RAIL)

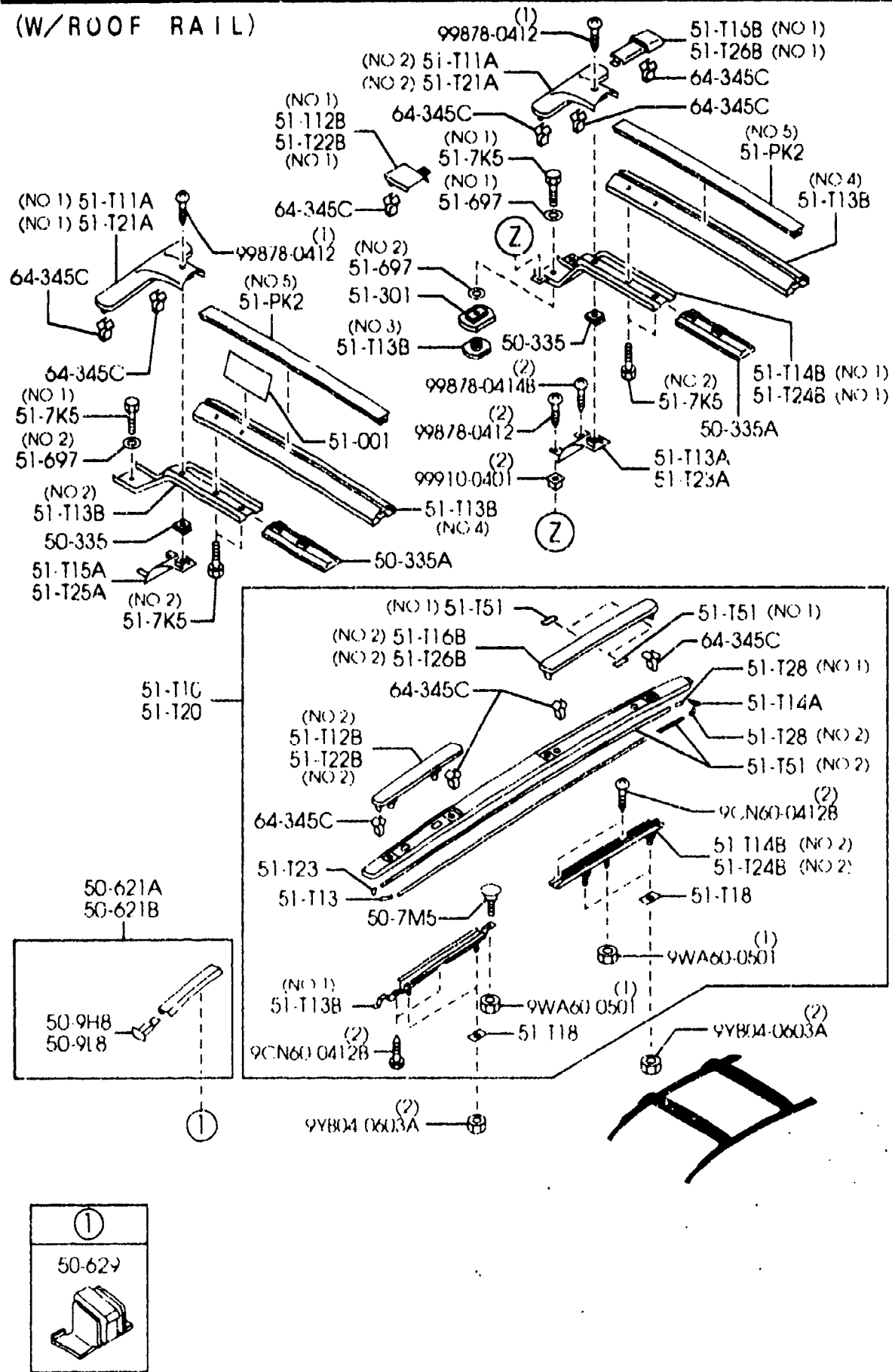

PART NO.	QTY	MODEL/RESTRICTION	MODEL/RESTRICTION	MODEL/RESTRICTION	FROM-TO
CONT'D					
B30D-51-U79	2	(W/ROOF RAIL)	(AVEC GALERIE)		
-----					
51-T13A		STAY(R), ROOF RACK	ETE(D), GALERIE		
-----					
BN5W-51-T13	1	(W/ROOF RAIL)	(AVEC GALERIE)		
-----					
51-T13B		STAY, ROOF RACK	ETE, GALERIE		
-----					
B25H-51-T13A	2	(ILLUST. NO. 1) (W/ROOF RAIL)	(AVEC GALERIE)		
BN5W-51-V32	2	(ILLUST. NO. 2) (W/ROOF RAIL)	(AVEC GALERIE)		
BN5W-51-V34	2	(ILLUST. NO. 3) (W/ROOF RAIL)	(AVEC GALERIE)		
BN5W-51-6A8	2	(ILLUST. NO. 4) (W/ROOF RAIL)	(AVEC GALERIE)		
-----					
51-T14A		PROTECTOR(RR), ROOF RACK	PROTECTEUR(AR), GALERIE		
-----					
B25H-51-T18A	2	(W/ROOF RAIL)	(AVEC GALERIE)		
-----					
51-T14B		STAY(R), ROOF RACK	ETE(D), GALERIE		
-----					
BN5W-51-T14	1	(ILLUST. NO. 1) (W/ROOF RAIL)	(AVEC GALERIE)		
B25H-51-T14A	1	(ILLUST. NO. 2) (W/ROOF RAIL)	(AVEC GALERIE)		
-----					
51-T15A		STAY(R), ROOF RACK	ETE(D), GALERIE		
-----					
BN5W-51-U32	1	(W/ROOF RAIL)	(AVEC GALERIE)		
-----					
51-T16B		CAP(R), REAR	BOUCHON(D), APRIE		
-----					
BN5W-51-T16	1	(ILLUST. NO. 1) (W/ROOF RAIL)	(AVEC GALERIE)		
B25H-51-T16B	1	(ILLUST. NO. 2) (W/ROOF RAIL)	(AVEC GALERIE)		
-----					
51-T18		GASKET, ROOF RACK	GARNITURE, GALERIE		
-----					
B25H-51-T29	8	(W/ROOF RAIL)	(AVEC GALERIE)		
-----					
51-T20		RACK(L), ROOF	CROCHET(G), TOIT		
-----					
B25H-51-T20C	1	(W/ROOF RAIL)	(AVEC GALERIE)		
-----					
51-T21A		COVER(L), ROOF RACK	COUVERCLE GALERIE(G)		
-----					
BN5W-51-5D2	1	(ILLUST. NO. 1) (W/ROOF RAIL)	(AVEC GALERIE)		
BN5W-51-5G2	1	(ILLUST. NO. 2) (W/ROOF RAIL)	(AVEC GALERIE)		

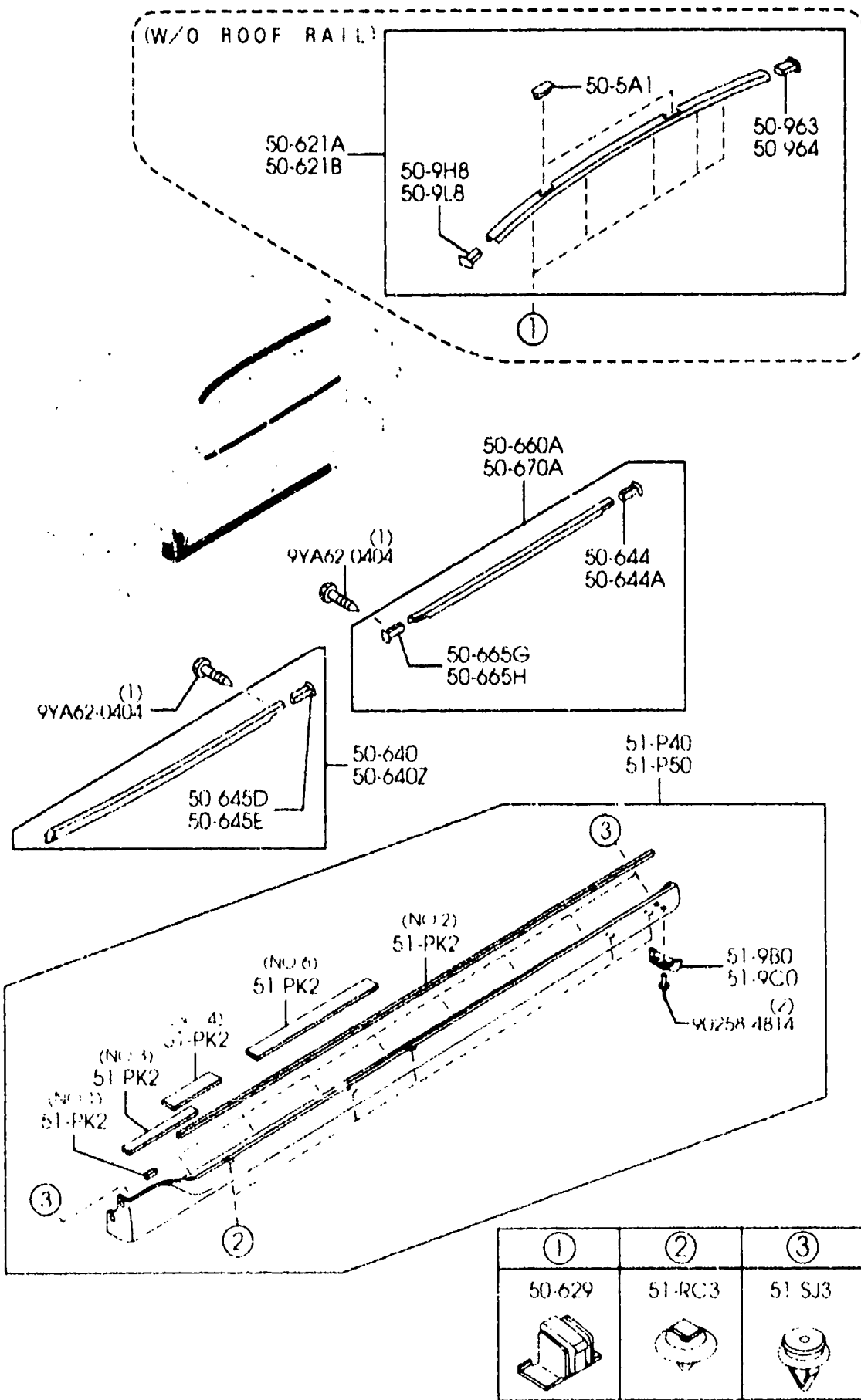

PART NO.	QTY	MODEL/RESTRICTION	MODEL/RESTRICTION	MODEL/RESTRICTION	FROM-TO
51-T22B		CAP(L),FRONT	BOUCHON(G),AVANT		
BN5W-51-T22	1	(ILLUST. NO.1) (W/ROOF RAIL)	(AVEC GALERIE)		
B25H-51-T22B	1	(ILLUST. NO.2) (W/ROOF RAIL)	(AVEC GALERIE)		
51-T23		PROTECTOR(L),ROOF RACK	PROTECTEUR(G),GALERIE		
B30D-51-U89	2	(W/ROOF RAIL)	(AVEC GALERIE)		
51-T23A		STAY(L),ROOF RACK	ETE(G),GALERIE		
BN5W-51-T23	1	(W/ROOF RAIL)	(AVEC GALERIE)		
51-T24B		STAY(L),ROOF RACK	ETE(G),GALERIE		
BN5W-51-T24	1	(ILLUST. NO.1) (W/ROOF RAIL)	(AVEC GALERIE)		
B25H-51-T24A	1	(ILLUST. NO.2) (W/ROOF RAIL)	(AVEC GALERIE)		
51-T25A		STAY(L),ROOF RACK	ETE(G),GALERIE		
BN5W-51-U42	1	(W/ROOF RAIL)	(AVEC GALERIE)		
51-T26B		CAP(L),REAR	BOUCHON(G),APRIE		
BN5W-51-T26	1	(ILLUST. NO.1) (W/ROOF RAIL)	(AVEC GALERIE)		
B25H-51-T26B	1	(ILLUST. NO.2) (W/ROOF RAIL)	(AVEC GALERIE)		
51-T28		GASKET,ROOF RACK	GARNITURE,GALERIE		
B25H-51-U79A	2	(ILLUST. NO.1) (W/ROOF RAIL)	(AVEC GALERIE)		
B25H-51-U89A	2	(ILLUST. NO.2) (W/ROOF RAIL)	(AVEC GALERIE)		
51-T51		PROTECTOR,ROOF RACK	PROTECTEUR,GALERIE		
B25H-51-RG2	8	(ILLUST. NO.1) (W/ROOF RAIL)	(AVEC GALERIE)		
B25H-51-U37B	4	(ILLUST. NO.2) (W/ROOF RAIL)	(AVEC GALERIE)		
51-001		TAPE	RUBAN		
BN5W-51-9N6	1	(W/ROOF RAIL)	(AVEC GALERIE)		
51-301		SPACER	RONDELLE		
BN5W-51-7P3	2	(W/ROOF RAIL)	(AVEC GALERIE)		

(W/ROOF RAIL)

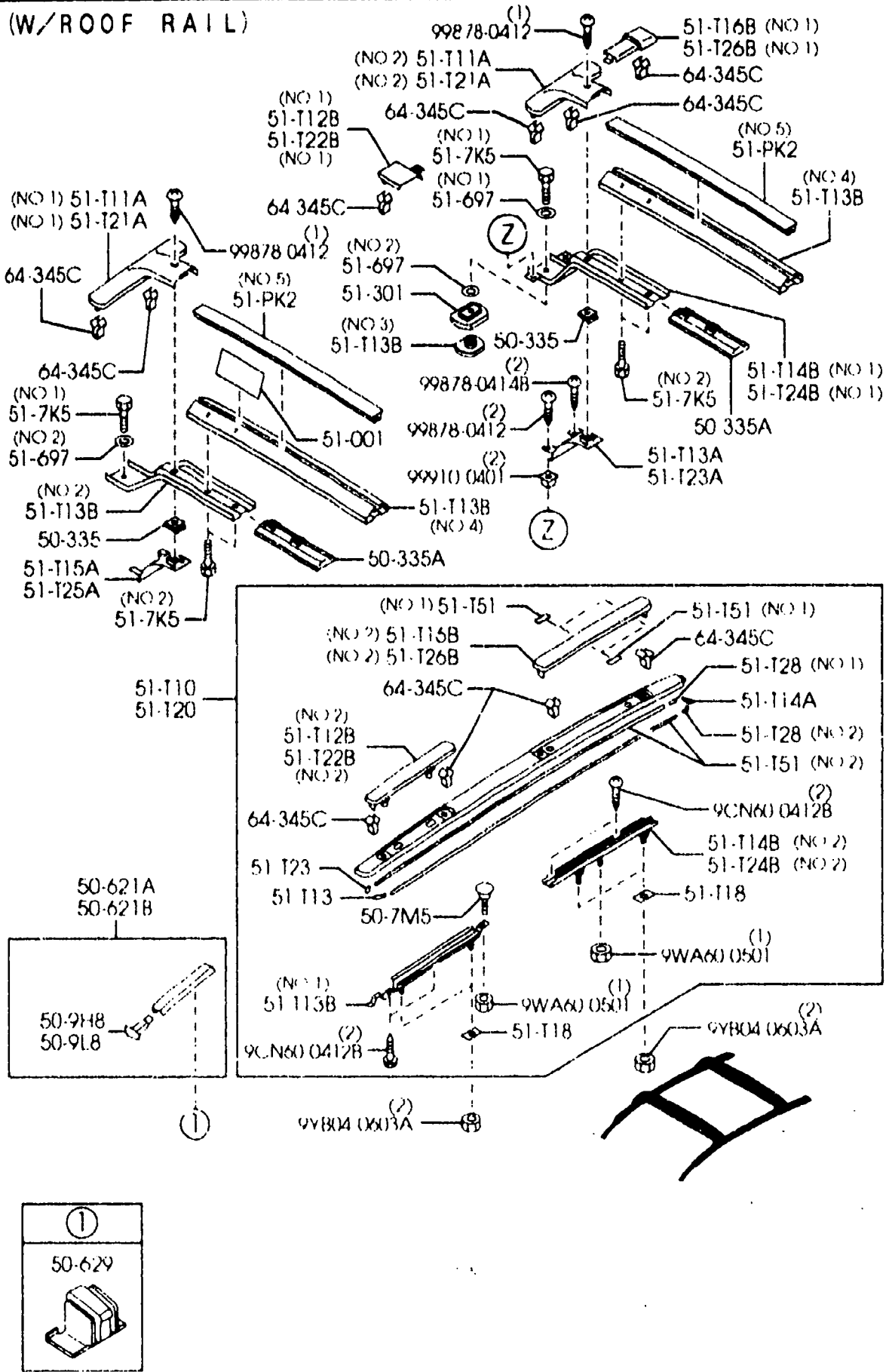

PART NO.	QTY	MODEL/RESTRICTION	MODEL/RESTRICTION	MODEL/RESTRICTION	FROM TO
51-697		WASHER	RONDELLE		
BN5W-51-959	2	(ILLUST. NO.1) (W/ROOF RAIL)	(AVEC GALERIE)		
BN6B-51-959	4	(ILLUST. NO.2) (W/ROOF RAIL)	(AVEC GALERIE)		
51-7K5		BOLT	BUULON, MOULAGE DE TOIT		
BN5W-51-7K5	4	(ILLUST. NO.1) (W/ROOF RAIL)	(AVEC GALERIE)		
BN6B-51-7K5	8	(ILLUST. NO.2) (W/ROOF RAIL)	(AVEC GALERIE)		
51-9B0		SPOILER(R), SIDE	SPOILER(D), LATERAL		
BN3V-51-9B1A	1				
51-9C0		SPOILER(L), SIDE	SPOILER(G), LATERAL		
BN3V-51-9C1A	1				
64-345C		SPRING, UPPER PLATE	RESSORT, PLAQUE SUP		
B25H-64-345	14	(W/ROOF RAIL)	(AVEC GALERIE)		

5060A SIDE PROTECTORS  
(4-DOOR)

5060A -1 SIDE PROTECTORS  
(4-DOOR)

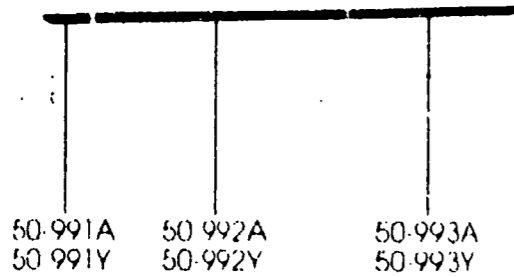

PART NO	QTY	MODEL/RESTRICTION	MODEL/RESTRICTION	MODEL/RESTRICTION	FROM TO
50-991A		PROTECTOR 'A' (R), SIDE	BAGUETTE PROTECTION 'A' (D)		
BJOE-50-681	1	(BLACK) (SPORT SUSP)	(SUSP. SPORTIVE)		
BJOF-50-681	1	(BODY COLOR) (SPORT SUSP)	(SUSP. SPORTIVE)		
HZ	EXT-	HZ SUNBURST YELLOW	HZ JAUNE BRULE		
SU	EXT-	A3E CLASSIC RED	A3E ROUGE CLASSIQUE		
08	EXT-	16W 24X BLACK MC	16W 24X MICA NOIR		
09	EXT-	A3D PURE WHITE	A3D BLANC PURE		
15	EXT-	22K PASSION RED MC	22K ROUGE PASSION METALL		
27	EXT-	23F GALAXY GOLD M.	23F OR GALAXIE M.		
4F	EXT-	4F CHAMPAGNE SILVER MC	4F ARGENT CHAMPAGNE MICA		
46	EXT-	18J GRACE GREEN MC	18J VERT GRACIEUX MC		
52	EXT-	24A STARRY BLUE MC	24A BLUE ETOILE MICA		
67	EXT-	22V 24G SUNLIGHT SILVER M	22V 24G ARGENT METALL. SOLEIL		
91	EXT-	23G ORIENT GREEN MC	23G VERT ORIENT MC		
50-991Y		PROTECTOR 'A' (L), SIDE	BAGUETTE 'A' (G), CO TE		
BJOE-50-691	1	(BLACK) (SPORT SUSP)	(SUSP. SPORTIVE)		
BJOF-50-691	1	(BODY COLOR) (SPORT SUSP)	(SUSP. SPORTIVE)		
HZ	EXT-	HZ SUNBURST YELLOW	HZ JAUNE BRULE		
SU	EXT-	A3E CLASSIC RED	A3E ROUGE CLASSIQUE		
08	EXT-	16W 24X BLACK MC	16W 24X MICA NOIR		
09	EXT-	A3D PURE WHITE	A3D BLANC PURE		
15	EXT-	22K PASSION RED MC	22K ROUGE PASSION METALL		
27	EXT-	23F GALAXY GOLD M.	23F OR GALAXIE M.		
4F	EXT-	4F CHAMPAGNE SILVER MC	4F ARGENT CHAMPAGNE MICA		
46	EXT-	18J GRACE GREEN MC	18J VERT GRACIEUX MC		
52	EXT-	24A STARRY BLUE MC	24A BLUE ETOILE MICA		
67	EXT-	22V 24G SUNLIGHT SILVER M	22V 24G ARGENT METALL. SOLEIL		
91	EXT-	23G ORIENT GREEN MC	23G VERT ORIENT MC		

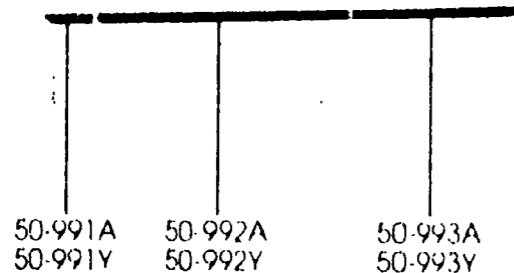

PART NO.	QTY	MODEL/RESTRICTION	MODEL/RESTRICTION	MODEL/RESTRICTION	FROM-TO
↑-----↑   50-992A   ↑-----↑					
BJOE-50-682	1	PROTECTOR 'B' (R), SIDE (BLACK) (SPORT SUSP)	BAGUETTE PROTECTION' B' (D) (SUSP. SPORTIVE)		
BJOF-50-682	1	(BODY COLOR) (SPORT SUSP)	(SUSP. SPORTIVE)		
HZ	EXT-	HZ SUNBURST YELLOW	HZ JAUNE BRULE		
SU	EXT-	A3E CLASSIC RED	A3E ROUGE CLASSIQUE		
08	EXT-	16W 24X BLACK MC	16W 24X MICA NOIR		
09	EXT-	A3D PURE WHITE	A3D BLANC PURE		
15	EXT-	22K PASSION RED MC	22K ROUGE PASSION METALL		
27	EXT-	23F GALAXY GOLD M.	23F OR GALAXIE M.		
4F	EXT-	4F CHAMPAGNE SILVER MC	4F ARGENT CHAMPAGNE MICA		
46	EXT-	18J GRACE GREEN MC	18J VERT GRACIEUX MC		
52	EXT-	24A STARRY BLUE MC	24A BLUE ETOILE MICA		
67	EXT-	22V 24G SUNLIGHT SILVER M	22V 24G ARGENT METALL. SOLEIL		
91	EXT-	23G ORIENT GREEN MC	23G VERT ORIENT MC		
↑-----↑   50-992Y   ↑-----↑					
BJOE-50-692	1	PROTECTOR 'B' (L), SIDE (BLACK) (SPORT SUSP)	BAGUETTE 'B' (G), CO TE (SUSP. SPORTIVE)		
BJOF-50-692	1	(BODY COLOR) (SPORT SUSP)	(SUSP. SPORTIVE)		
HZ	EXT-	HZ SUNBURST YELLOW	HZ JAUNE BRULE		
SU	EXT-	A3E CLASSIC RED	A3E ROUGE CLASSIQUE		
08	EXT-	16W 24X BLACK MC	16W 24X MICA NOIR		
09	EXT-	A3D PURE WHITE	A3D BLANC PURE		
15	EXT-	22K PASSION RED MC	22K ROUGE PASSION METALL		
27	EXT-	23F GALAXY GOLD M.	23F OR GALAXIE M.		
4F	EXT-	4F CHAMPAGNE SILVER MC	4F ARGENT CHAMPAGNE MICA		
46	EXT-	18J GRACE GREEN MC	18J VERT GRACIEUX MC		
52	EXT-	24A STARRY BLUE MC	24A BLUE ETOILE MICA		
67	EXT-	22V 24G SUNLIGHT SILVER M	22V 24G ARGENT METALL. SOLEIL		
91	EXT-	23G ORIENT GREEN MC	23G VERT ORIENT MC		



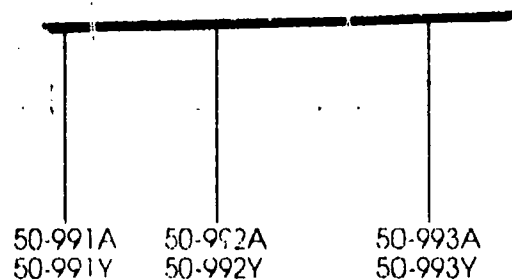

PART NO.	QTY	MODEL/RESTRICTION	MODEL/RESTRICTION	MODEL/RESTRICTION	FROM TO
↑-----↑   50-993A   ↑-----↑		PROTECTOR 'C' (R), SIDE	BAGUETTE PROTECTION 'C' (D)		
BJOE-50-683	1	(BLACK) (SPORT SUSP)	(SUSP. SPORTIVE)		
BJOF-50-683	1	(BODY COLOR) (SPORT SUSP)	(SUSP. SPORTIVE)		
HZ	EXT-	HZ SUNBURST YELLOW	HZ JAUNE BRULE		
SU	EXT-	A3E CLASSIC RED	A3E ROUGE CLASSIQUE		
08	EXT-	16W 24X BLACK MC	16W 24X MICA NOIR		
09	EXT-	A3D PURE WHITE	A3D BLANC PURE		
15	EXT-	22K PASSION RED MC	22K ROUGE PASSION METALL		
27	EXT-	23F GALAXY GOLD M.	23F OR GALAXIE M.		
4F	EXT-	4F CHAMPAGNE SILVER MC	4F ARGENT CHAMPAGNE MICA		
46	EXT-	18J GRACE GREEN MC	18J VERT GRACIEUX MC		
52	EXT-	24A STARRY BLUE MC	24A BLUE ETOILE MICA		
67	EXT-	22V 24G SUNLIGHT SILVER M	22V 24G ARGENT METALL. SOLEIL		
91	EXT-	23G ORIENT GREEN MC	23G VERT ORIENT MC		
↑-----↑   50-993Y   ↑-----↑		PROTECTOR 'C' (L), SIDE	BAGUETTE 'C' (G), CO TE		
BJOE-50-693	1	(BLACK) (SPORT SUSP)	(SUSP. SPORTIVE)		
BJOF-50-693	1	(BODY COLOR) (SPORT SUSP)	(SUSP. SPORTIVE)		
HZ	EXT-	HZ SUNBURST YELLOW	HZ JAUNE BRULE		
SU	EXT-	A3E CLASSIC RED	A3E ROUGE CLASSIQUE		
08	EXT-	16W 24X BLACK MC	16W 24X MICA NOIR		
09	EXT-	A3D PURE WHITE	A3D BLANC PURE		
15	EXT-	22K PASSION RED MC	22K ROUGE PASSION METALL		
27	EXT-	23F GALAXY GOLD M.	23F OR GALAXIE M.		
4F	EXT-	4F CHAMPAGNE SILVER MC	4F ARGENT CHAMPAGNE MICA		
46	EXT-	18J GRACE GREEN MC	18J VERT GRACIEUX MC		
52	EXT-	24A STARRY BLUE MC	24A BLUE ETOILE MICA		
67	EXT-	22V 24G SUNLIGHT SILVER M	22V 24G ARGENT METALL. SOLEIL		
91	EXT-	23G ORIENT GREEN MC	23G VERT ORIENT MC		

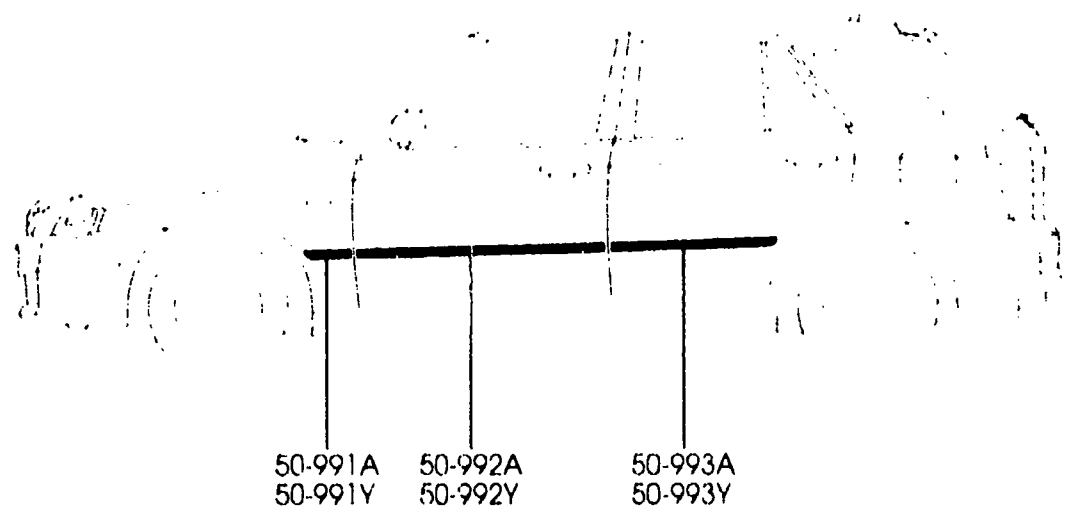

PART NO.	QTY	MODEL/RESTRICTION	MODEL/RESTRICTION	MODEL/RESTRICTION	FROM-TO
+-----+   50-991A   +-----+					
BJOF-50-681	1	PROTECTOR'A'(R),SIDE	BAGUETTE PROTECTION' A'(D)		
HZ	EXT-	HZ SUNBURST YELLOW	HZ JAUNE BRULE		
SU	EXT-	A3E CLASSIC RED	A3E RQUE CLASSIQUE		
08	EXT-	16W 24X BLACK MC	16W 24X MICA NOIR		
09	EXT-	A3D PURE WHITE	A3D BLANC PURE		
46	EXT-	18J GRACE GREEN MC	18J VERT GRACIEUX MC		
50	EXT-	22A SUPREME BLUE MC	22A ROUGE NEUF		
67	EXT-	22V 24G SUNLIGHT SILVER M	22V 24G ARGENT METALL. SOLEIL		
+-----+   50-991Y   +-----+					
BJOF-50-691	1	PROTECTOR'A'(L),SIDE	BAGUETTE 'A' (G), CO TE		
HZ	EXT-	HZ SUNBURST YELLOW	HZ JAUNE BRULE		
SU	EXT-	A3E CLASSIC RED	A3E RQUE CLASSIQUE		
08	EXT-	16W 24X BLACK MC	16W 24X MICA NOIR		
09	EXT-	A3D PURE WHITE	A3D BLANC PURE		
46	EXT-	18J GRACE GREEN MC	18J VERT GRACIEUX MC		
50	EXT-	22A SUPREME BLUE MC	22A ROUGE NEUF		
67	EXT-	22V 24G SUNLIGHT SILVER M	22V 24G ARGENT METALL. SOLEIL		
+-----+   50-992A   +-----+					
BJOF-50-682	1	PROTECTOR'B'(R),SIDE	BAGUETTE PROTECTION' B'(D)		
HZ	EXT-	HZ SUNBURST YELLOW	HZ JAUNE BRULE		
SU	EXT-	A3E CLASSIC RED	A3E RQUE CLASSIQUE		
08	EXT-	16W 24X BLACK MC	16W 24X MICA NOIR		
09	EXT-	A3D PURE WHITE	A3D BLANC PURE		
46	EXT-	18J GRACE GREEN MC	18J VERT GRACIEUX MC		
50	EXT-	22A SUPREME BLUE MC	22A ROUGE NEUF		
67	EXT-	22V 24G SUNLIGHT SILVER M	22V 24G ARGENT METALL. SOLEIL		
+-----+   50-992Y   +-----+					
BJOF-50-692	1	PROTECTOR'B'(L),SIDE	BAGUETTE 'B' (G), CO TE		
HZ	EXT-	HZ SUNBURST YELLOW	HZ JAUNE BRULE		
SU	EXT-	A3E CLASSIC RED	A3E RQUE CLASSIQUE		

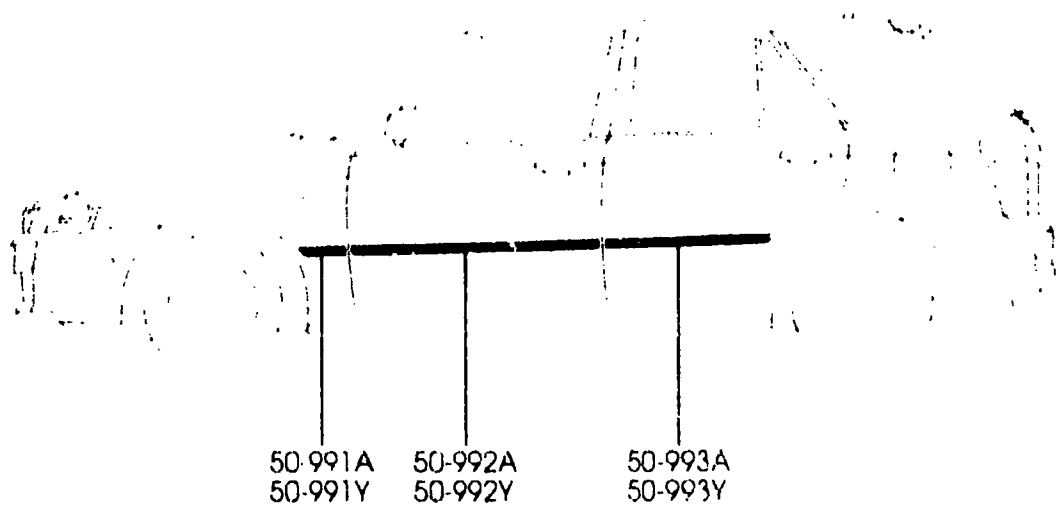

PART NO.	QTY	MODEL/RESTRICTION	MODEL/RESTRICTION	MODEL/RESTRICTION	FROM-TO
CONT'D					
08	EXT-	16W 24X BLACK MC	16W 24X MICA NOIR		
09	EXT-	A3D PURE WHITE	A3D BLANC PURE		
46	EXT-	18J GRACE GREEN MC	18J VERT GRACIEUX MC		
50	EXT-	22A SUPREME BLUE MC	22A ROUGE NEUF		
67	EXT-	22V 24G SUNLIGHT SILVER M	22V 24G ARGENT METALL. SOLEIL		
		+-----+   50-993A   +-----+			
BJOF-50-683	1	PROTECTOR 'C' (R), SIDE	BAGUETTE PROTECTION 'C' (D)		
HZ	EXT-	HZ SUNBURST YELLOW	HZ JAUNE BRULE		
SU	EXT-	A3E CLASSIC RED	A3E ROUGE CLASSIQUE		
08	EXT-	16W 24X BLACK MC	16W 24X MICA NOIR		
09	EXT-	A3D PURE WHITE	A3D BLANC PURE		
46	EXT-	18J GRACE GREEN MC	18J VERT GRACIEUX MC		
50	EXT-	22A SUPREME BLUE MC	22A ROUGE NEUF		
67	EXT-	22V 24G SUNLIGHT SILVER M	22V 24G ARGENT METALL. SOLEIL		
		+-----+   50-993Y   +-----+			
BJOF-50-693	1	PROTECTOR 'C' (L), SIDE	BAGUETTE 'C' (G), CO TE		
HZ	EXT-	HZ SUNBURST YELLOW	HZ JAUNE BRULE		
SU	EXT-	A3E CLASSIC RED	A3E ROUGE CLASSIQUE		
08	EXT-	16W 24X BLACK MC	16W 24X MICA NOIR		
09	EXT-	A3D PURE WHITE	A3D BLANC PURE		
46	EXT-	18J GRACE GREEN MC	18J VERT GRACIEUX MC		
50	EXT-	22A SUPREME BLUE MC	22A ROUGE NEUF		
67	EXT-	22V 24G SUNLIGHT SILVER M	22V 24G ARGENT METALL. SOLEIL		

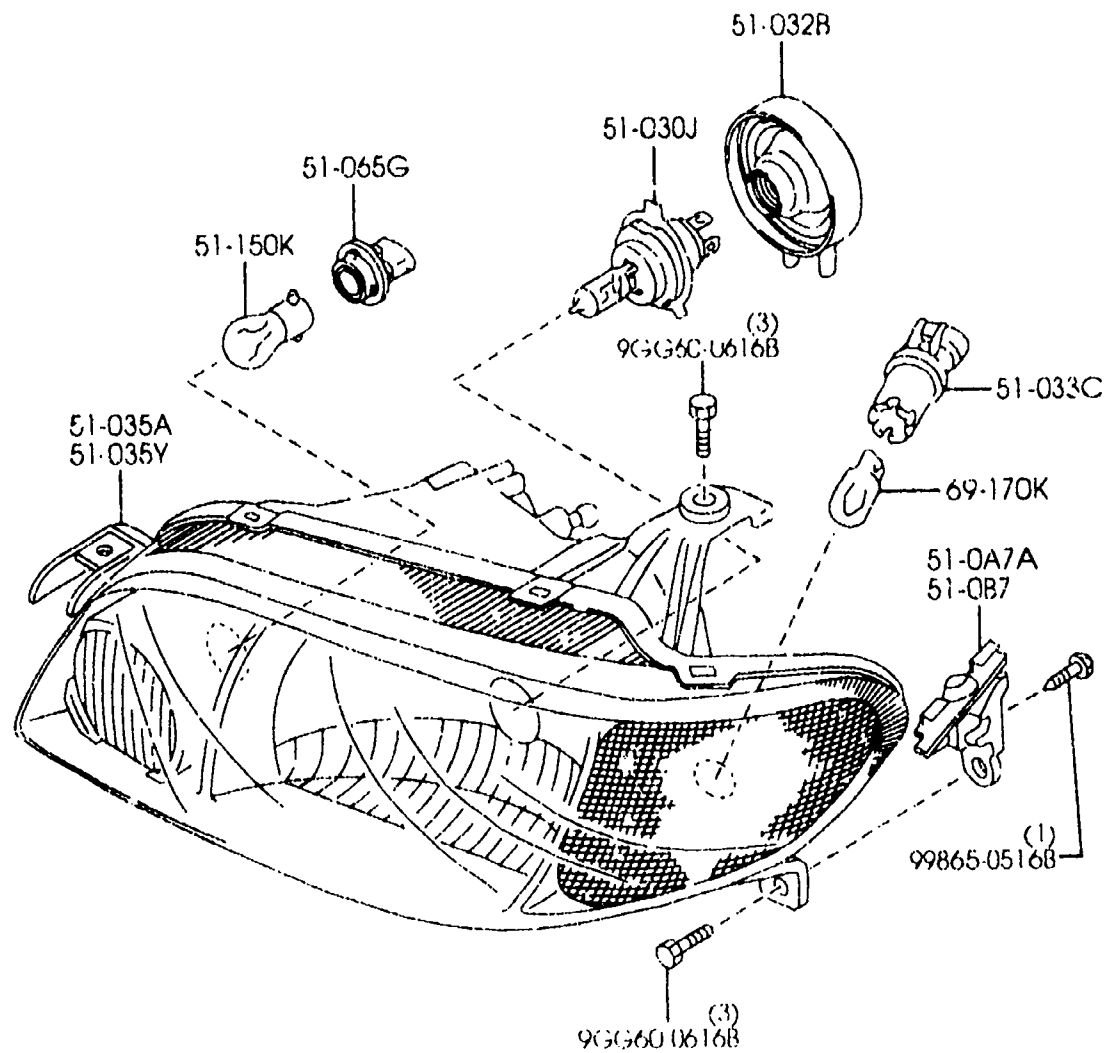

PART NO.	QTY	MODEL/RESTRICTION	MODEL/RESTRICTION	MODEL/RESTRICTION	FROM - TO
51-0A7A B30D-51-0A7A	1	BRACKET(R), HEAD LAMP	SUPPORT(D), PHARE		
51-0B7 B30D-51-0B7A	1	BRACKET(L), HEAD LAMP	SUPPORT(G), PHARE		
51-030J 99703-8605	2	BULB 12V 60/55W	AMPOULE 12V 60/55W		
51-032B A065-51-033	2	COVER	COUVERCLE		
51-033C B25D-51-0HB	2	SOCKET	DOUILLE		
51-035A BL8D-51-0K0D	1	UNIT(R), HEAD LAMP (ALUMI. BEZEL) (SPORT SUSP)	UNITE (SUSP. SPORTIVE)		
51-035Y BL8E-51-0K0D	1	UNIT(L), HEAD LAMP (ALUMI. BEZEL) (SPORT SUSP)	UNITE (SUSP. SPORTIVE)		
51-065G BL8D-51-064	2	SOCKET, F. COMB. LAMP	DOUILLE, FEU COMBINE AV		
51-150K 99701-4278Y	2	BULB A12V 27/8W	AMPOULE A12V 27/8W		
69-170K 99701-6050	2	BULB, INTERIOR MIRROR 12V 5W	AMPOULE 12V 5W		

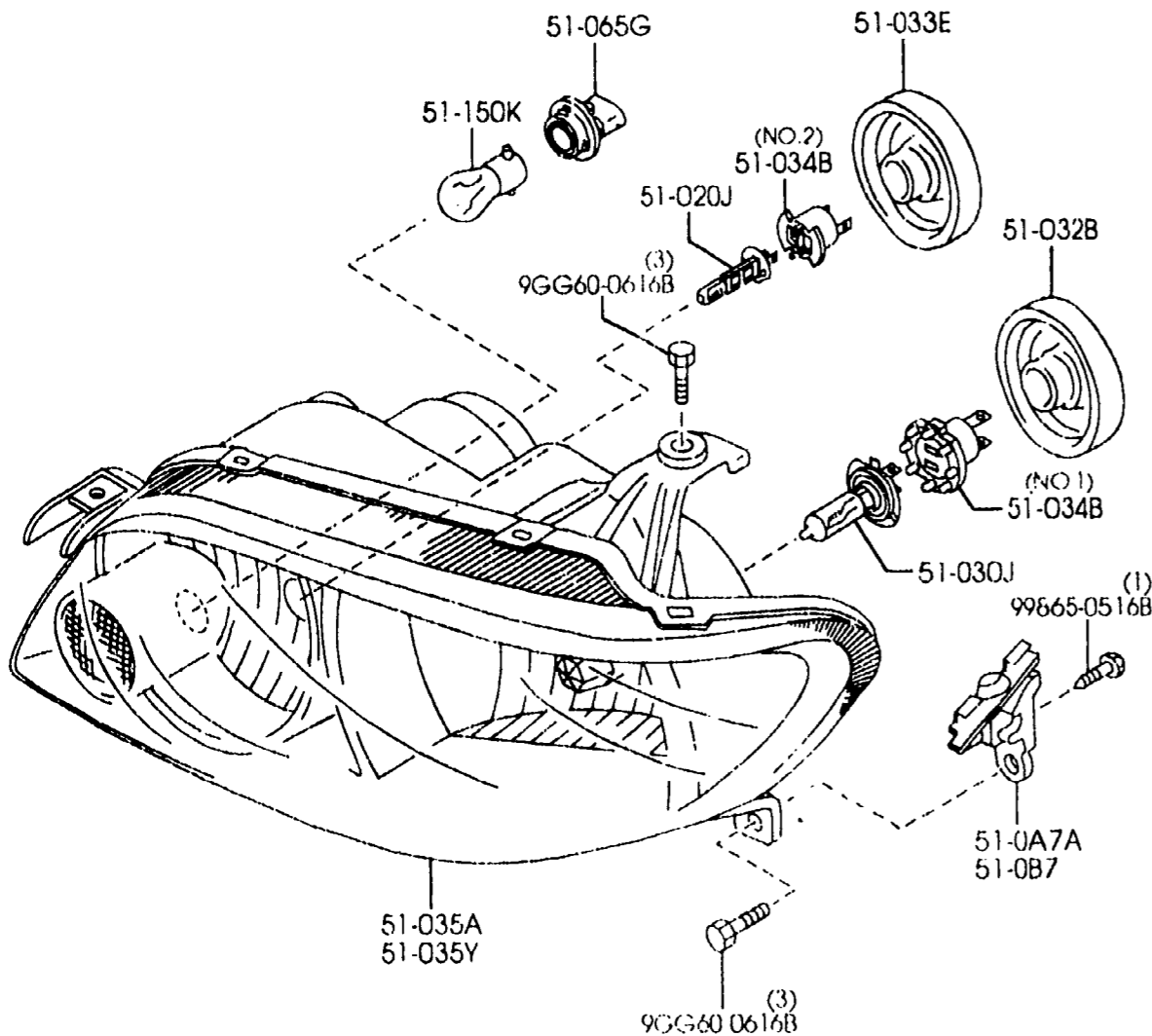

PART NO.	QTY	MODEL/RESTRICTION	MODEL/RESTRICTION	MODEL/RESTRICTION	FROM-TO
51-0A7A B30D-51-0A7A	1	BRACKET(R), HEAD LAMP	SUPPORT(D), PHARE		
51-0B7 B30D-51-0B7A	1	BRACKET(L), HEAD LAMP	SUPPORT(G), PHARE		
51-020J 99703-7650	2	BULB HEAD LAMP 12V 65W	AMPOULE 12V 65W		
51-030J 90703-2550	2	BULB 1H 12V 55W	AMPOULE 1H 12V 55W		
51-032B BN4G-51-0A1	2	COVER	COUVRICLÉ		
51-033E T061-51-0A1	2	COVER, SOCKET-NO. 2	COUVERCLE SOQUET NO.2		
51-034B B28V-51-0A3 B28W-51-0A3	2 2	HOLDER, BULB (ILLUST. NO.1) (ILLUST. NO.2)	PORTE-AMPOULE		
51-035A BN5V-51-0K0B A (BN5V-51-0K0C) *BN5V-51-0K0C	1 1 1	UNIT(R), HEAD LAMP	UNITE		-1511
51-035Y BN5V-51-0L0B A (BN5V-51-0L0C) *BN5V-51-0L0C	1 1 1	UNIT(L), HEAD LAMP	UNITE		-1511
51-065G GA2A-51-064	2	SOCKET, F. COMB. LAMP (G)	DOUILLE, FEU COMBINE AV (G)		
51-150K 99701-4278Y	2	BULB A12V 27/8W	AMPOULE A12V 27/8W		
1511 BJ22* -470477					



(SPORT SUSP)

★ This part is not serviced.

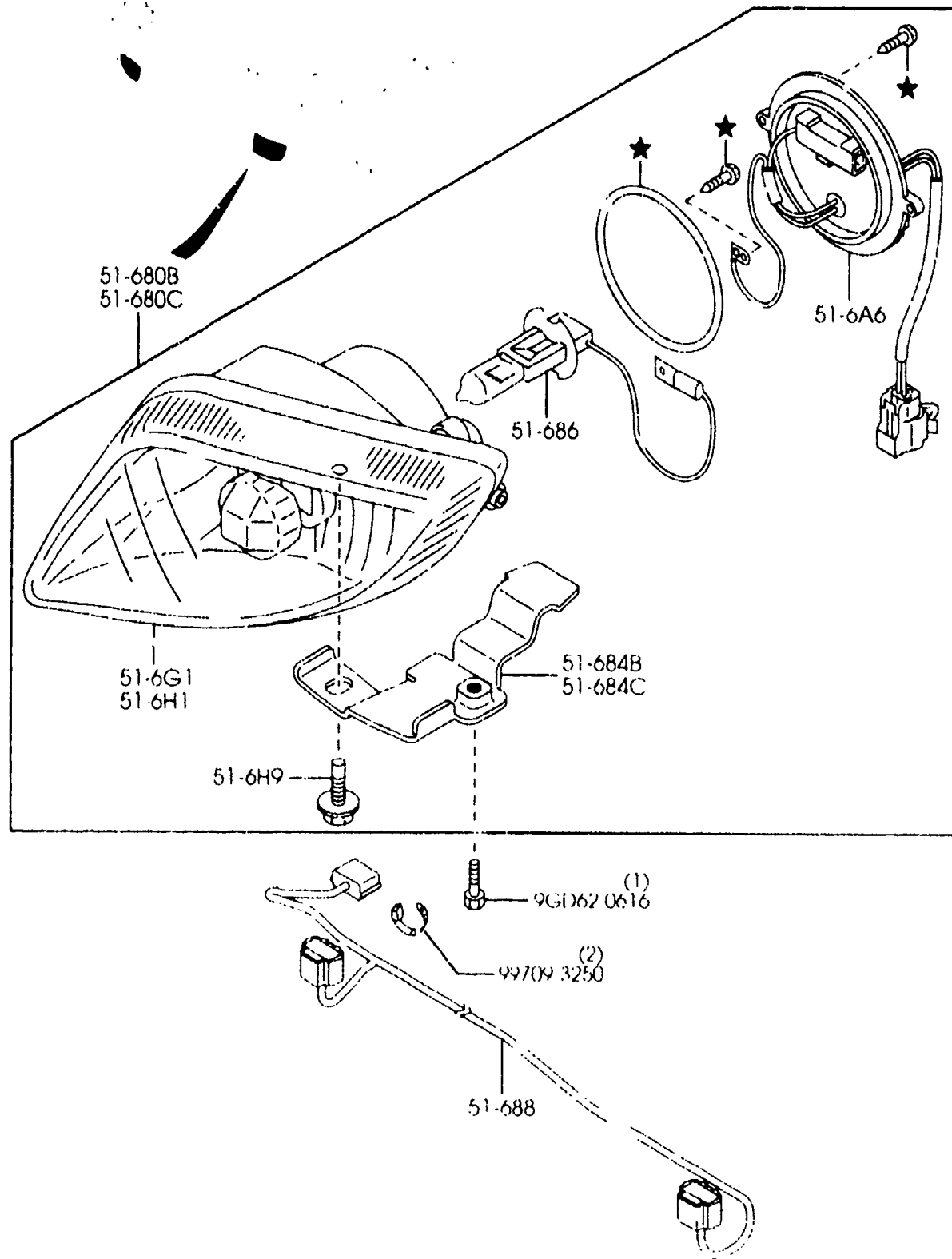

(MPS SUSP)

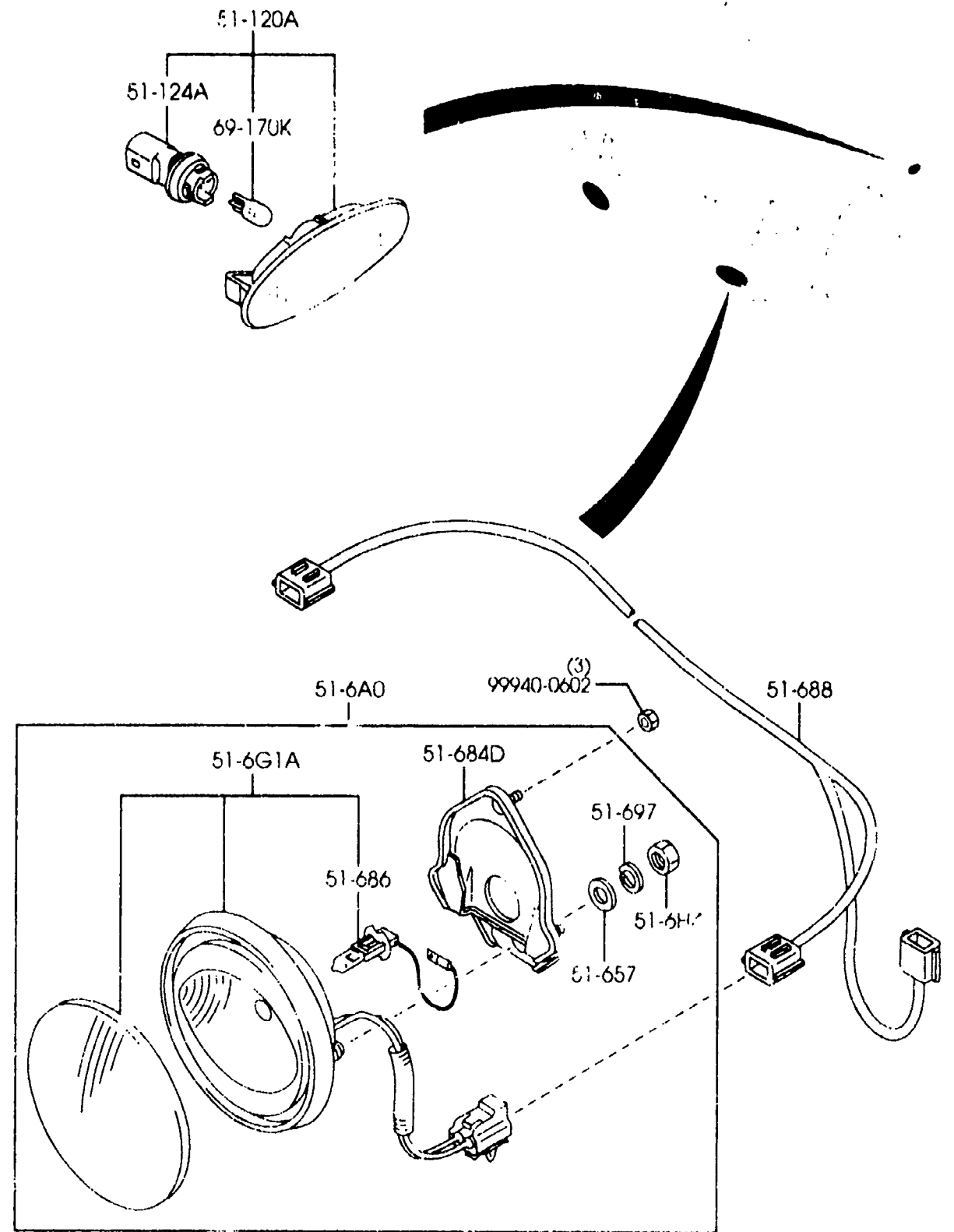

(SPORT SUSP)

★ This part is not serviced

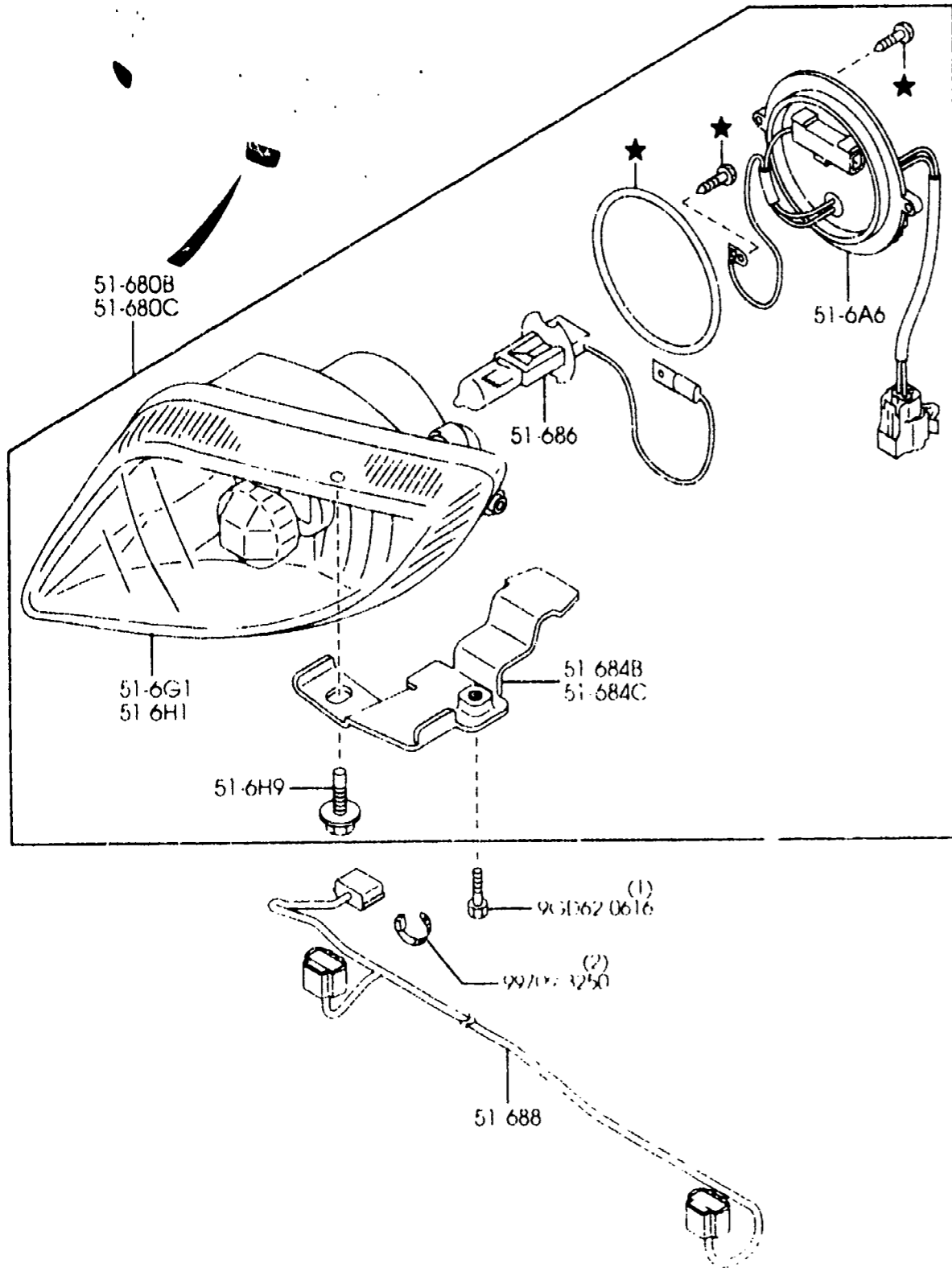

PART NO.	QTY	MODEL/RESTRICTION	MO-PL/RESTRICTION	MODEL/RESTRICTION	FROM-TO
51-120A B01W-51-120	2	LAMP, SIDE TURN (MPS SUSP)	CLIGNOTANT (SUSP. MPS)		
51-124A B01W-51-124	2	SOCKET, SIDE TURN (MPS SUSP)	DOUILLE, (SUSP. MPS)		
51-6A0 BN5V-51-680	2	LAMP, FRONT FOG (MPS SUSP)	PHARE, ANTI-BROUILLARD (SUSP. MPS)		
51-6A6 T060-51-664	2	COVER, SOCKET-F. FOG LAMP (SPORT SUSP)	COUVERCLE, DOUILLE-P. A. BRO (SUSP. SPORTIVE)		
51-6G1 TC86-51-68X	1	UNIT(R), FOG LAMP (SPORT SUSP)	GROUPE(D), PROJ. A. BROUIL (SUSP. SPORTIVE)		
51-6G1A BN5V-51-68X	2	UNIT, FOG LAMP (MPS SUSP)	UNITE, FEU BROUILLARD (SUSP. MPS)		
51-6H1 TC86-51-69X	1	UNIT(L), FOG LAMP (SPORT SUSP)	GROUPE(G), PROJ. A. BROUIL (SUSP. SPORTIVE)		
51-6H4 B28V-51-6H4	2	NUT (MPS SUSP)	ECROU (SUSP. MPS)		
51-6H9 GG2M-51-6H9	2	SCREW SET (SPORT SUSP)	JEU DE VIS (SUSP. SPORTIVE)		
51-657 B28V-51-657	2	WASHER, FOG LAMP-FRT (MPS SUSP)	RONDELLE, PHARE A. BROUIL- AV (SUSP. MPS)		
51-680B TC86-51-680	1	LAMP(R), F. FOG (SPORT SUSP)	PHARE(D), ANTI-BROUILLARD (SUSP. SPORTIVE)		
51-680C TC86-51-690	1	LAMP(L), F. FOG (SPORT SUSP)	PHARE(G), ANTI-BROUILLARD (SUSP. SPORTIVE)		
51-684B T060-51-684	1	BRACKET(R) F. FOG LAMP (SPORT SUSP)	SUPPORT(D), PHARE A. BROUIL (SUSP. SPORTIVE)		
51-684C T060-51-694	1	BRACKET(L), F. FOG LAMP (SPORT SUSP)	SUPPORT(G), PHARE-A. BROUIL (SUSP. SPORTIVE)		

5105A FRONT COMBINATION LAMPS  
(4-DOOR)

(2/2)

(MPS SUSP)

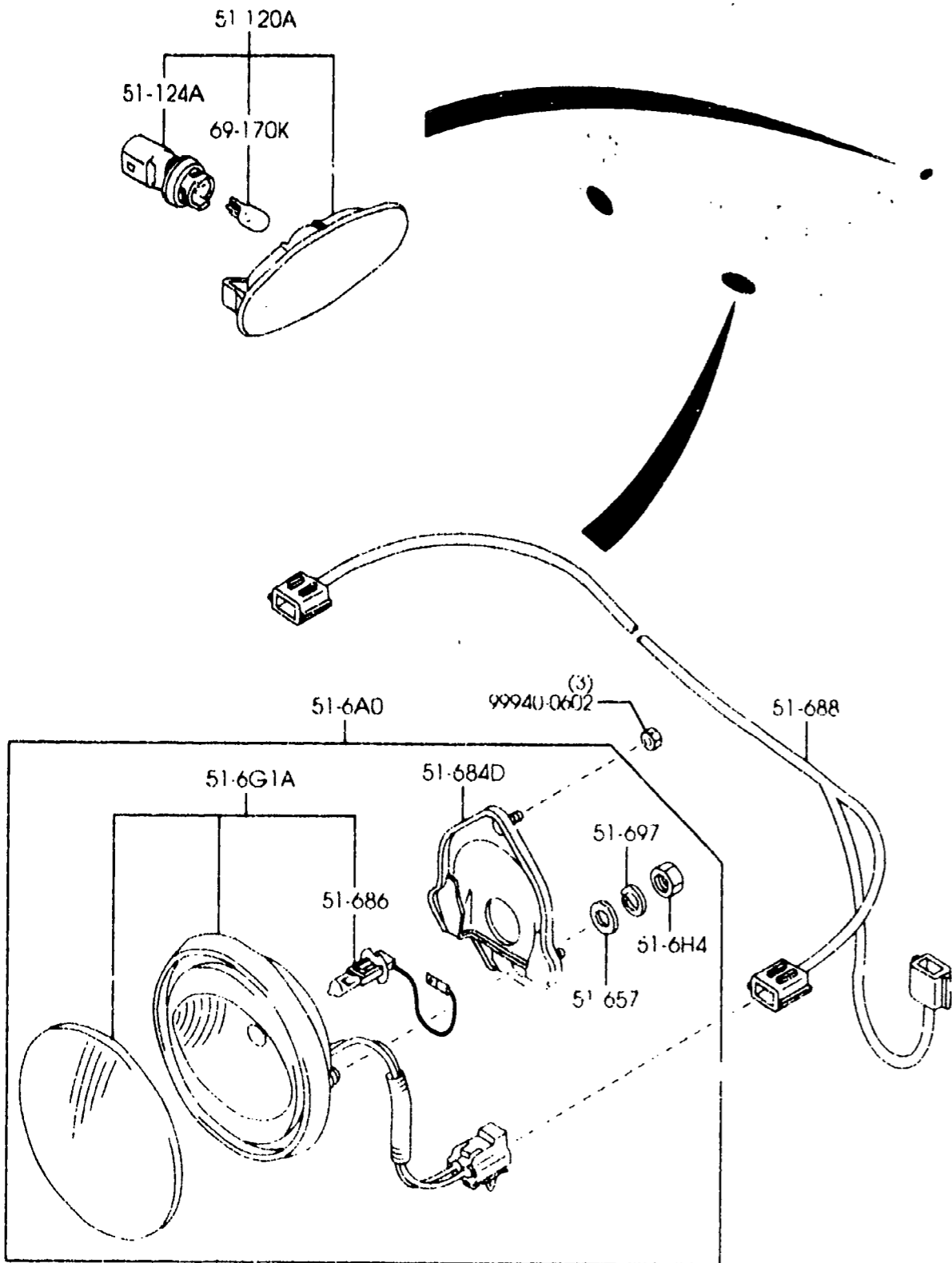

5105A -2 \* FRONT COMBINATION LAMPS  
(4-DOOR)

PART NO.	QTY	MODEL/RESTRICTION	MODEL/RESTRICTION	MODEL/RESTRICTION	FROM-TO
51-684D B28V-51-684A	2	BRACKET, F. FOG LAMP (MPS SUSP)	SUPPORT, PROJECT A. BR OU (SUSP. MPS)		
51-686 99703-4550	2	BULB, FRONT FOG LAMP 12V 55W	AMPOULE, PROJECT. ANT IBRO1 12V 55W		
51-688 BL8D-51-688B B30P-51-688A	1	CORD, FRONT FOG LAMP (SPORT SUSP)	CABLE, PROJECT. ANTIB ROUI. (SUSP. SPORTIVE)		
51-697 B28V-51-697	2	WASHER (MPS SUSP)	RONDELLE (SUSP. MPS)		
69-170K 99701-6050	2	BULB, INTERIOR MIRROR (MPS SUSP)	AMPOULE 12V 5W (SUSP. MPS)		

AUBA09

(2B56872)

CAT AUBA09-02

2001-07

3-E 6



5105B FRONT COMBINATION LAMPS  
(5-DOOR)

5105B -1 \* FRONT COMBINATION LAMPS  
(5-DOOR)

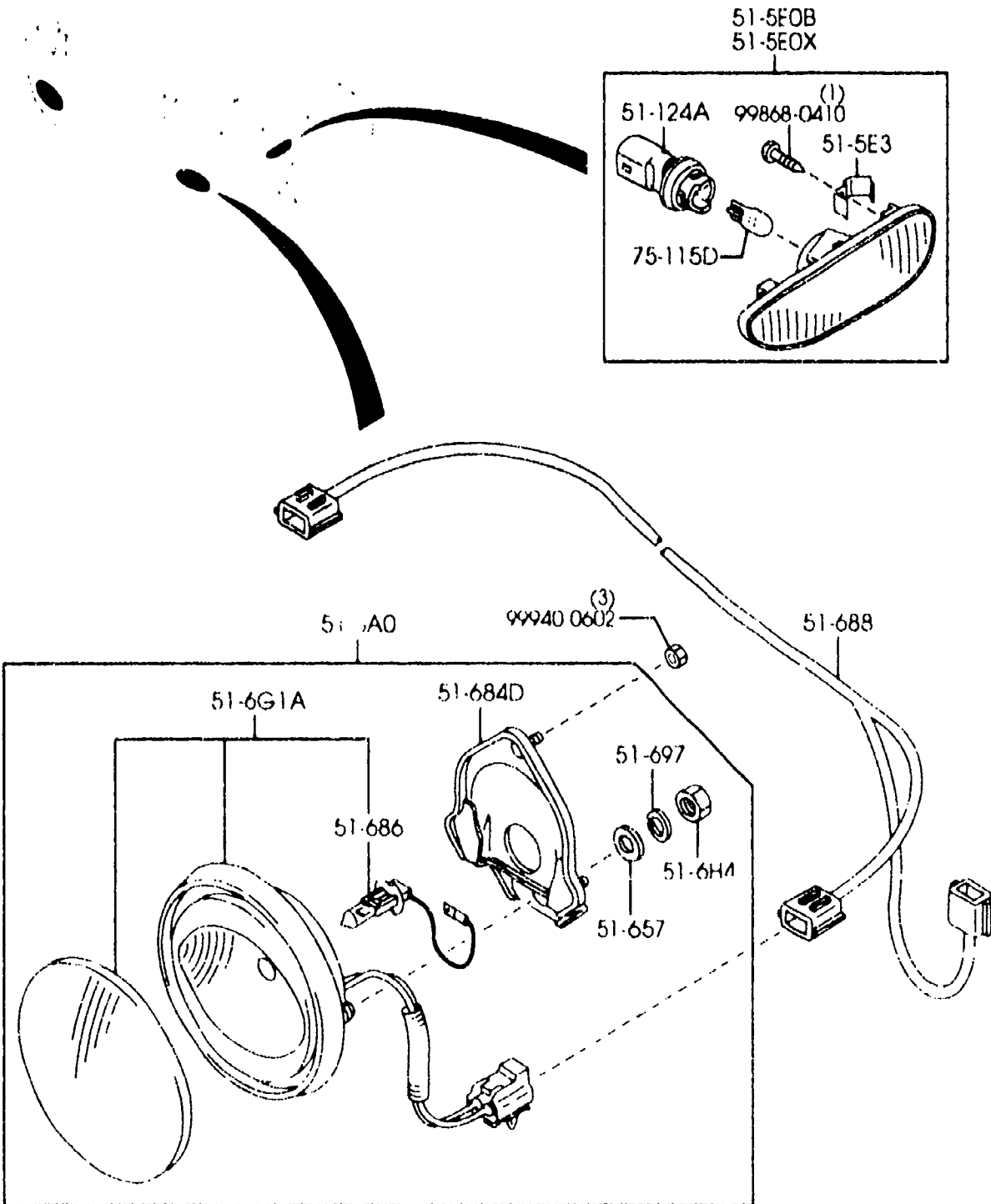

PART NO	QTY	MODEL/RESTRICTION	MODEL/RESTRICTION	MODEL/RESTRICTION	FROM-TO
51-124A H380-51-5E2	2	SOCKET, SIDE TURN	DOUILLE,		
51-5E0B BNSV-51-5E0B	1	LAMP(R), F. SIDE MARKE R			
51-5E0X BNSV-51-5F0B	1	LAMP(L), F. SIDE MARKE R			
51-5E3 BNSV-51-5E3B	2	SPRING, FRONT SIDE	RESSORT, LATERALE AV		
51-6A0 BNSV-51-680	2	LAMP, FRONT FOG	PHARE, ANTI-BROUILLAR D		
51-6G1A BNSV-51-68X	2	UNIT, FOG LAMP	UNITE, FEU BROUILLARD		
51-6H4 B28V-51-6H4	2	NUT	ECROU		
51-657 B28V-51-657	2	WASHER, FOG LAMP-FRT	RONDELLE, PHARE A. BRO UI-AV		
51-684D B28V-51-684A	2	BRACKET, F. FOG LAMP	SUPPORT, PROJECT A. BR OU		
51-686 99703-4550	2	BULB, FRONT FOG LAMP 12V 55W	AMPOULE, PROJECT. ANT IBROI 12V 55W		
51-688 BNSV-51-688A	1	CORD, FRONT FOG LAMP	CABLE, PROJECT. ANTIB ROUI.		
51-697 B28V-51-697	2	WASHER	RONDELLE		
75-115D 99701-6049	2	BULB 12V 3CP	AMPOULE 12V 3CP		

5110A REAR COMBINATION LAMPS  
(4-DOOR)

5110A -1 REAR COMBINATION LAMPS  
(4-DOOR)

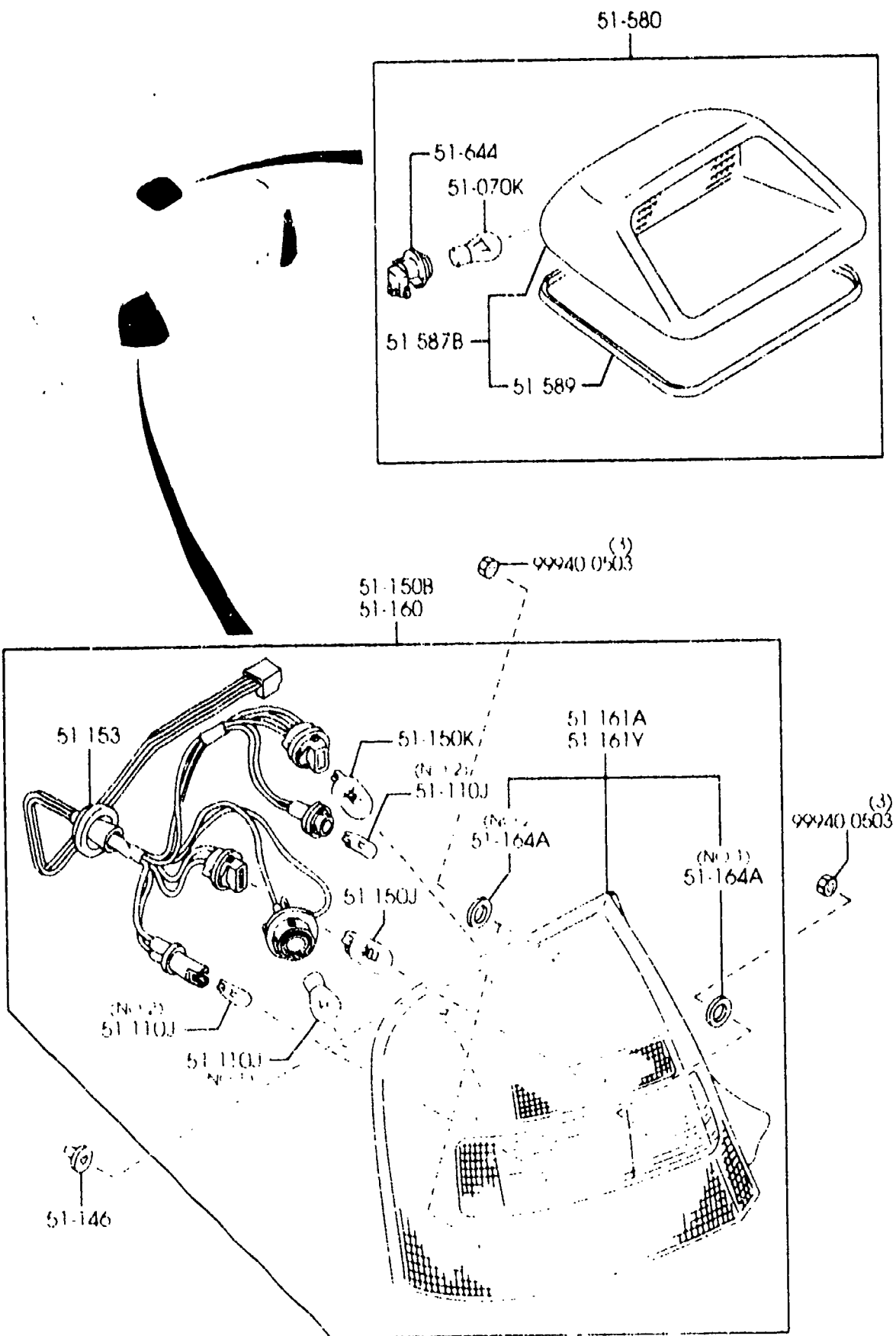

PART NO.	QTY	MODEL/RESTRICTION	MODEL/RESTRICTION	MODEL/RESTRICTION	FROM-TO
51-070K	1	BULB	AMPOULE		
99701-3210	1	12V 21W (W/O RR.SPOILER)	12V 21W		
51-110J	2	BULB	AMPOULE		
99701-3210Y	2	12V 21W YELLOW (ILLUST. NO.1)	12V 21W YELLOW		
51-146	4	GROMMET, SCREW-R.COMB	ANNEAU,		
GA7B-51-146	2				
51-150B	1	LAMP(R), RR COMB.	LAMPE(D), COMBINAISON ARR		
BJOE-51-150B	1				
51-150J	2	BULB	AMPOULE		
99700-6210	2	12V 21W	12V 21W		
51-150K	2	BULB	AMPOULE		
99700-8215	2	12V 21/5W	12V 21/5W		
51-153	2	SOCKET, RR.COMB.	DOUILLE		
BJOE-51-155A	2				
51-160	1	LAMP(L), RR COMB.	LAMPE(G), COMBIN. AR		
BJOE-51-160B	1				
51-161A	1	LENS & BODY(R), RR CO MB.	LENTILLE ET CORPS(D)		
BJOE-51-170B	1				
51-161Y	1	LENS & BODY(L), RR CO MB.	LENTILLE ET CORPS(G)		
BJOE-51-180B	1				
51-164A	2	GASKET, RR COMB.	JOINT, FEU COMBINE AR		
B25D-51-153	2	(ILLUST. NO.1)			
GD7A-51-153	4	(ILLUS. NO.2)			
51-580	1	LAMP, STOP-HI.MOUNT.	FEU, STOP-IN.ELEV.		
B25D-51-580A	1	(W/O RR.SPOILER)			

5110A REAR COMBINATION LAMPS  
(4-DOOR)

5110A -2 \* REAR COMBINATION LAMPS  
(4-DOOR)

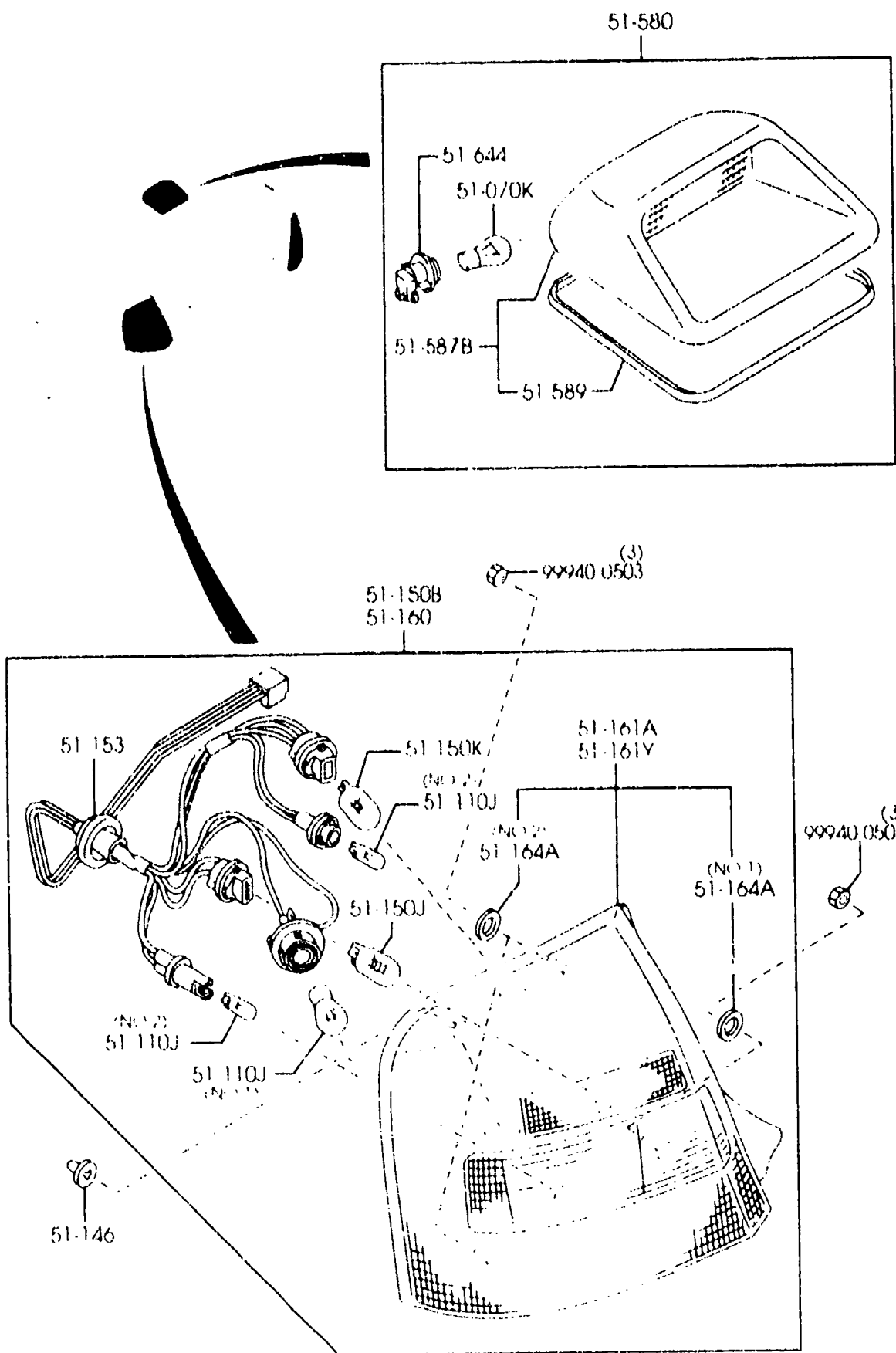

PART NO	QTY	MODEL/RESTRICTION	MODEL/RESTRICTION	MODEL/RESTRICTION	FROM-TO
CONT'D					
05	INT-	BN1 BN2 GRAY	BN1 BN2 GRIS		
65	INT-	BN4 OFF-BLACK	BN4 NOIR CLAIR		
80	INT-	BN3 BEIGE	BN3 BEIGE		
		↑-----↑			
		51-587B			
		↑-----↑			
B25D-51-58YA	1	COVER, STOP LAMP-HI. MOUNT (W/O RR.SPOILER)	COUVERCLE, FEUX STOP-M.H.		
05	INT-	BN1 BN2 GRAY	BN1 BN2 GRIS		
65	INT-	BN4 OFF-BLACK	BN4 NOIR CLAIR		
80	INT-	BN3 BEIGE	BN3 BEIGE		
		↑-----↑			
		51-589			
		↑-----↑			
B25D-51-582A	1	PROTECTOR, STOP LAMP-HI. MO (W/O RR.SPOILER)	PROTECT., FEU STOP-EL EVE		
		↑-----↑			
		51-644			
		↑-----↑			
B01A-51-644	1	SOCKET, REAR FOG LAMP (W/O RR.SPOILER)	DOUILLE, PHARE A-BROU ILL.		

5110B REAR COMBINATION LAMPS  
(5-DOOR)

5110B -1 \* REAR COMBINATION LAMPS  
(5-DOOR)

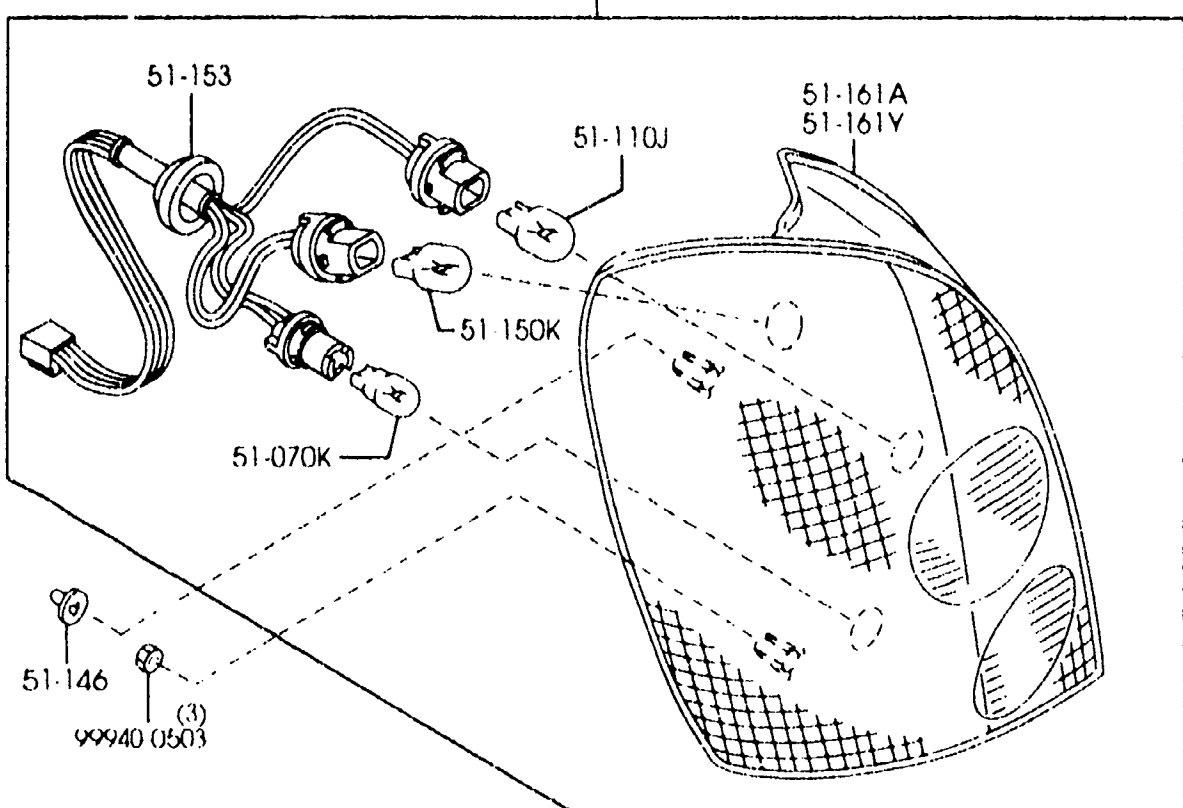
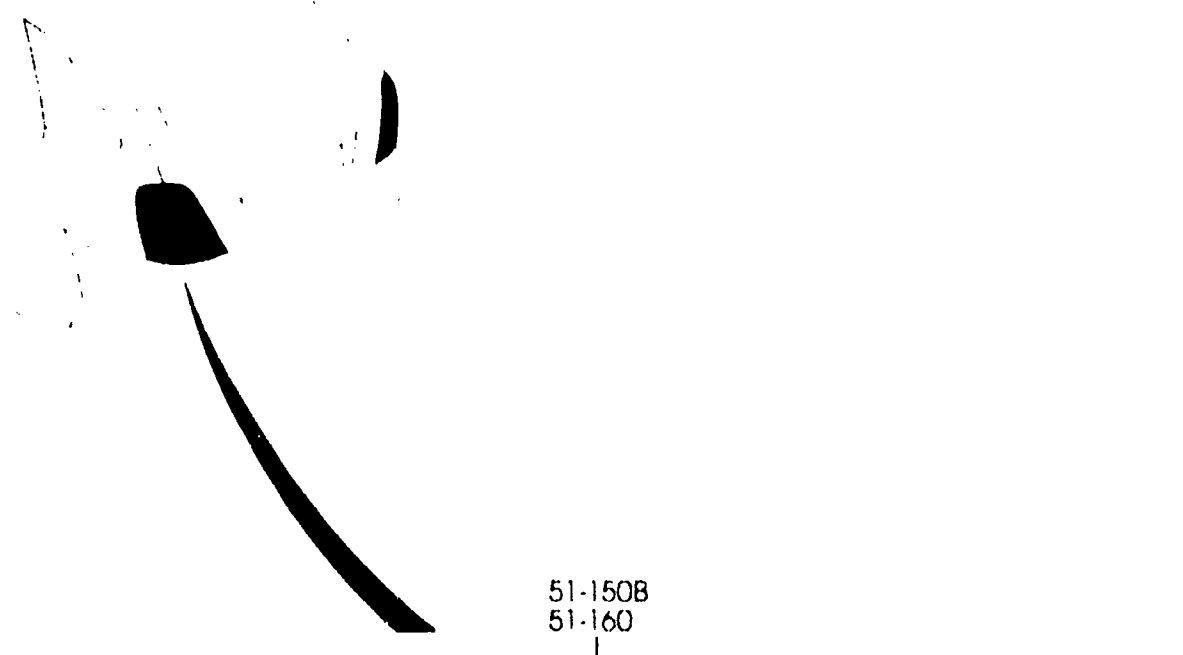

PART NO	QTY	MODEL/RESTRICTION	MODEL/RESTRICTION	MODEL/RESTRICTION	FROM-TO
51-070K 99700-7180	2	BULB A12V 18.4W	AMPOULE A12V 18.4W		
51-110J 99700-6210Y	2	BULB	AMPOULE		
51-146 GA7B-51-146	2	GROMMET, SCREW-R. COMB	ANNEAU,		
51-150B BN5V-51-150	1	LAMP(R), RR COMB.	LAMPE(D), COMBINAISON ARR		
51-150K 99700-8215	2	BULB 12V 21/5W	AMPOULE 12V 21/5W		
51-153 BN5V-51-155	2	SOCKET, RR. COMB.	DOUILLE		
51-160 BN5V-51-160	1	LAMP(L), RR COMB.	LAMPE(G), COMBIN. AR		
51-161A BN5V-51-170	1	LENS & BODY(R), RR CO MB.	LENTILLE ET CORPS(D) ,		
51-161Y BN5V-51-180	1	LENS & BODY(L), RR CO MB.	LENTILLE ET CORPS(G) ,		

AUBA09

(2B56890)

CAT. AUBA09-02

2001-07

(4DR)

51-270

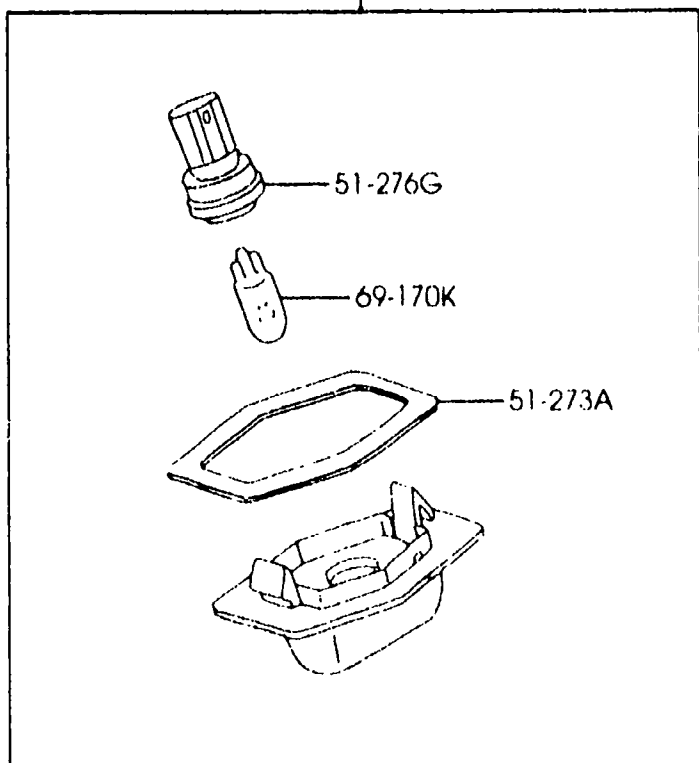

(5DR)

51-270

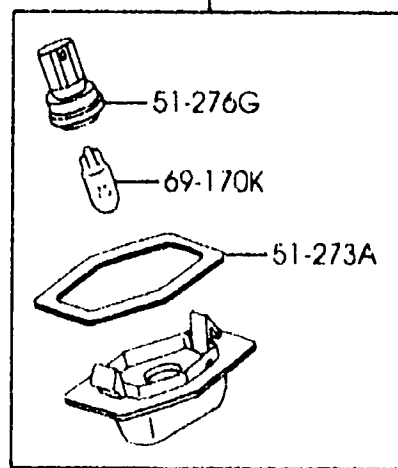

50-180K

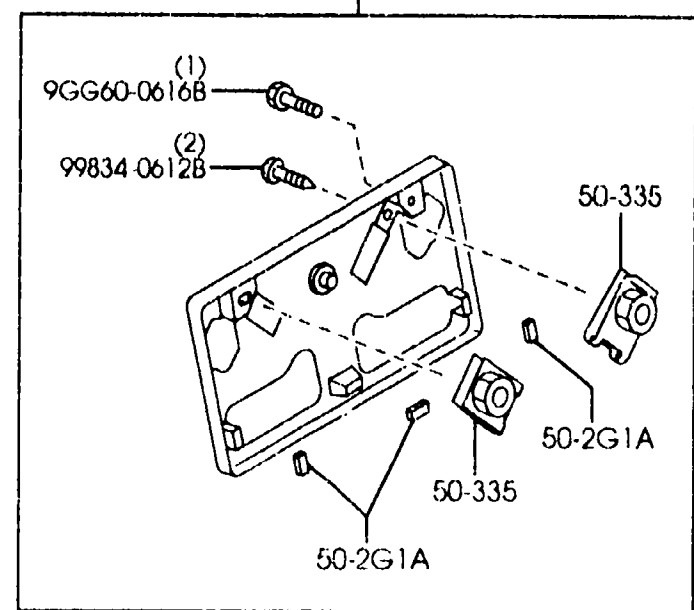

(4DR)

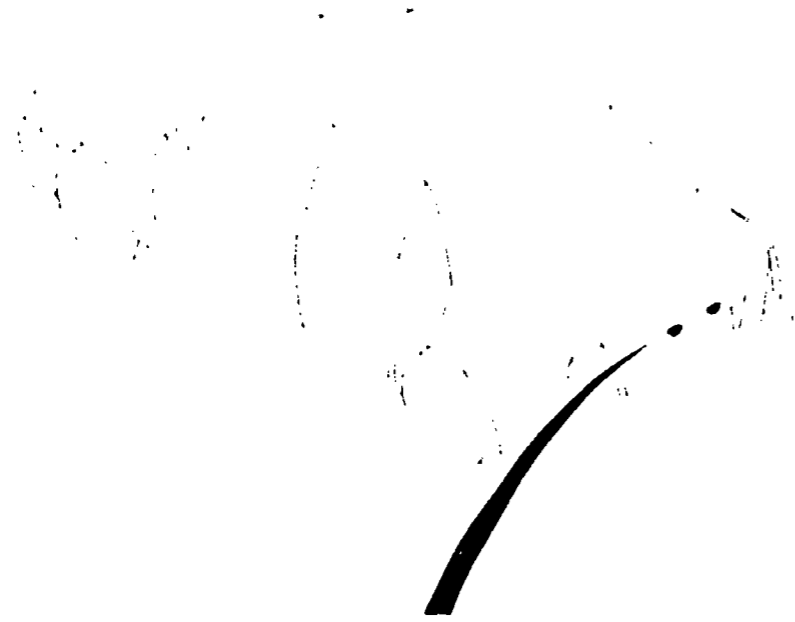

51-270

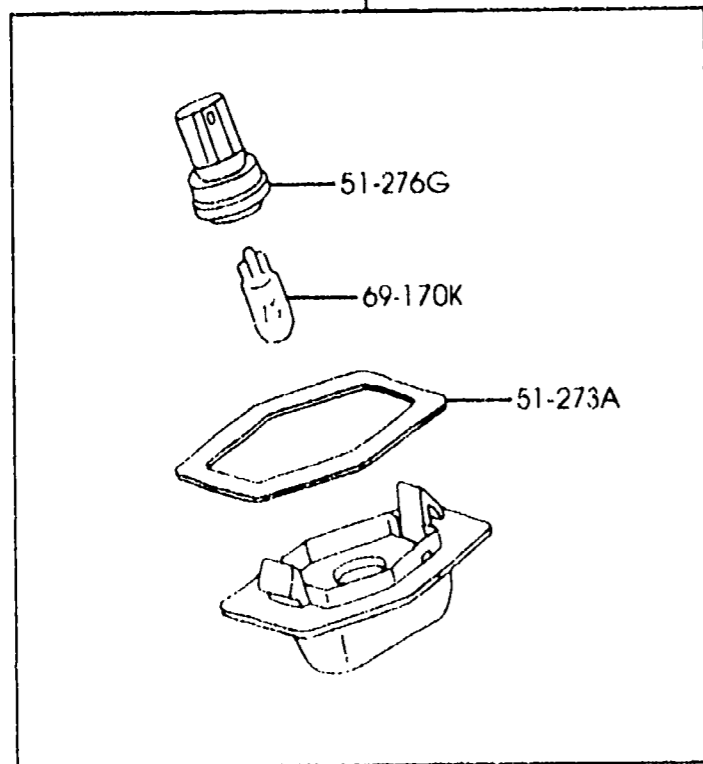

5120A -1 \* LICENSE LAMPS

PART NO.	QTY	MODEL/RESTRICTION	MODEL/RESTRICTION	MODEL/RESTRICTION	FROM-TO
50-180K BN5V-50-2N0	1	HOLDER, LICENSE PLATE (5DR)	SUPPORT, PLAQUE IMMATRICUL (5PRTS)		
50-261A BN5V-50-261	3	RUBBER, SEAL (5DR)	CAOUTCHOUC ETANCHEITE (5PRTS)		
50-335 FB01-50-133C	2	NUT, CLIP (5DR)	ECROU, CLIP (5PRTS)		
51-270 BN5V-51-270 NC10-51-270B	2 2	LAMP, LICENSE (5DR) (4DR)	FEU DE PLAQUE (5PRTS) (4PRTS)		
51-273A NC10-51-273A	2	GASKET, LICENSE	JOINT, FEU DE PLAQUE		
51-276G NC10-51-272	2	SOCKET, LICENSE LAMP	DOUILLE, FEU DE PLAQUE		
69-170K 99701-6050	2	BULB, INTERIOR MIRROR 12V 5W	AMPOULE 12V 5W		

5125A INTERIOR LAMPS  
(W/O SUNROOF)

5125A -1 \* INTERIOR LAMPS  
(W/O SUNROOF)

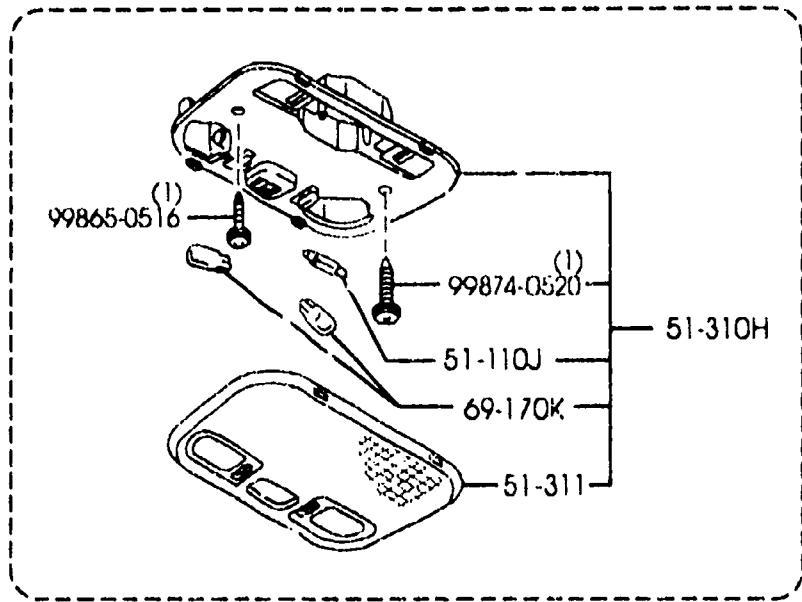

(5 DR)

(4 DR)

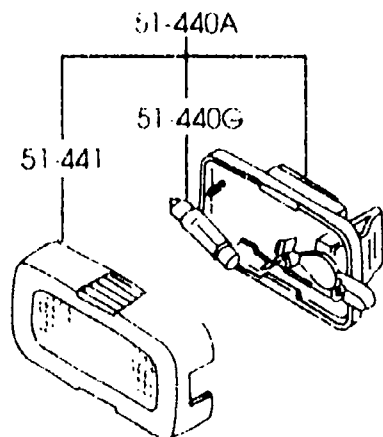
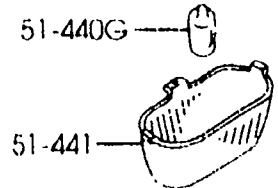

(2B56910)

PART NO.	QTY	MODEL/RESTRICTION	MODEL/RESTRICTION	MODEL/RESTRICTION	FROM-TO
51-110J		BULB	AMPOULE		
99700-5080L	1	12V/8W	12V/8W		
51-310H		LAMP, INTERIOR & MAP	PLAFONNIER ET LAMPE LECT.		
B30E-51-310	1				
03	INT-	BN1 BN2 BN4 LIGHT GRAY	BN1 BN2 BN4 GRIS CLAIR		
80	INT-	BN3 BEIGE	BN3 BEIGE		
51-311		LENS, INTERIOR LAMP	LENTILLE, PLAFONNIER		
B25F-51-311	1				
51-440A		LAMP, CARGO ROOM	LAMPE,		
BN0C-51-440A	1 (5DR)		(5PRTS)		
51-440G		BULB	AMPOULE		
BN0C-51-4C5	1 (5DR)		(5PRTS)		
99701-6050	1	12V 5W (W/LUGGAGE ROOM LAMP)	12V 5W		
		(4DR)	(4PRTS)		
51-441		LENS	VERRE		
BN0C-51-441A	1 (5DR)		(5PRTS)		
B130-51-441	1 (W/LUGGAGE ROOM LAMP)		(4PRTS)		
		(4DR)			
69-170K		BULB, INTERIOR MIRROR	AMPOULE		
99701-6050	2	12V 5W	12V 5W		

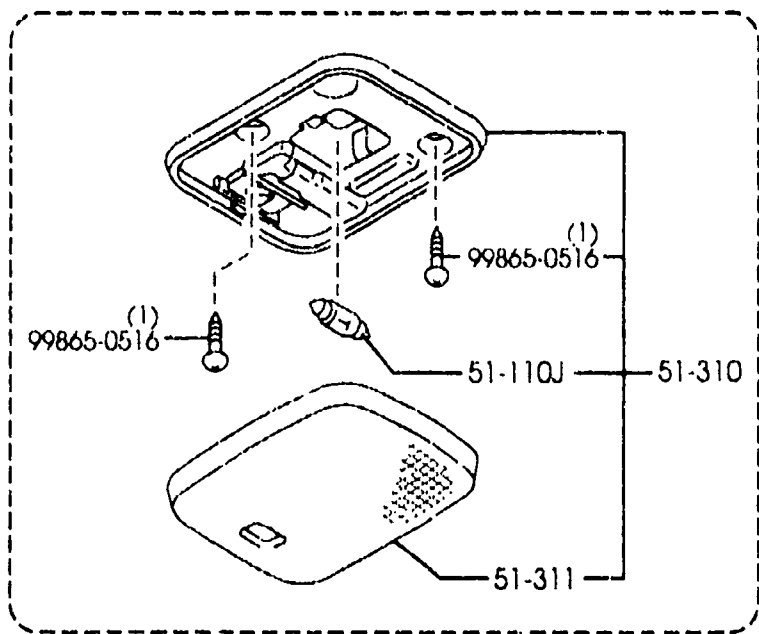

(4 DR)

(5 DR)

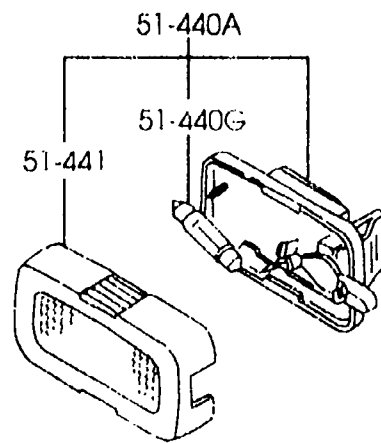
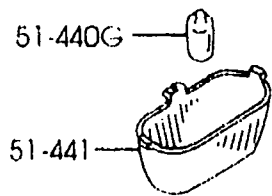

PART NO.	QTY	MODEL/RESTRICTION	MODEL/RESTRICTION	MODEL/RESTRICTION	FROM-TO
51-110J		BULB	AMPOULE		
99700-5100L	1	12V 10W	12V 10W		
51-310		LAMP, INTERIOR	PLAFONNIER		
BL2A-51-310	1				
03	INT-	BN1 BN2 BN4 LIGHT GRAY	BN1 BN2 BN4 GRIS CLAIR		
80	INT-	BN3 BEIGE	BN3 BEIGE		
51-311		LENS, INTERIOR LAMP	LENTILLE, PLAFONNIER		
B25K-51-311	1				
51-440A		LAMP, CARGO ROOM	LAMPE,		
BN0C-51-440A	1 (5DR)		(5PRTS)		
51-440G		BULB	AMPOULE		
BN0C-51-4C5	1 (5DR)		(5PRTS)		
99701-6050	1	12V 5W (W/LUGGAGE ROOM LAMP)	12V 5W		
		(4DR)	(4PRTS)		
51-441		LENS	VERRE		
BN0C-51-441A	1 (5DR)		(5PRTS)		
B130-51-441	1	(W/LUGGAGE ROOM LAMP)			
		(4DR)	(4PRTS)		



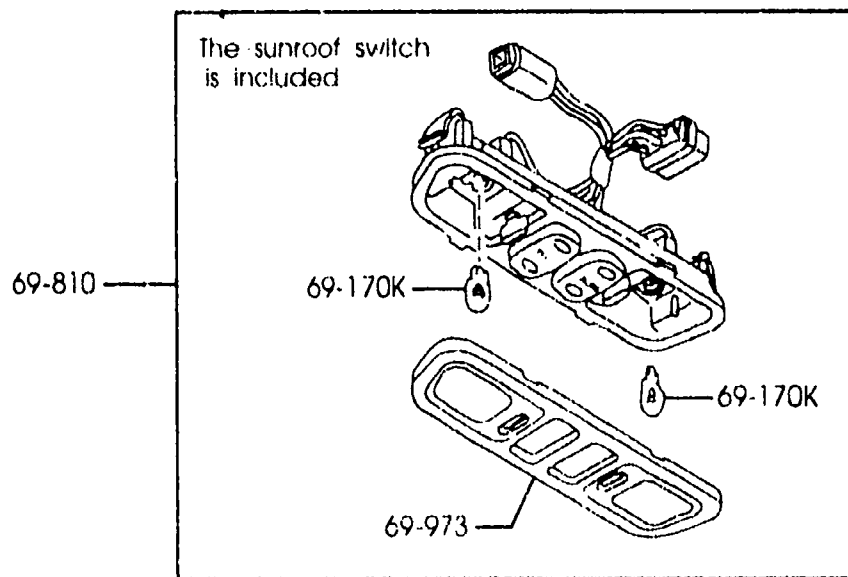
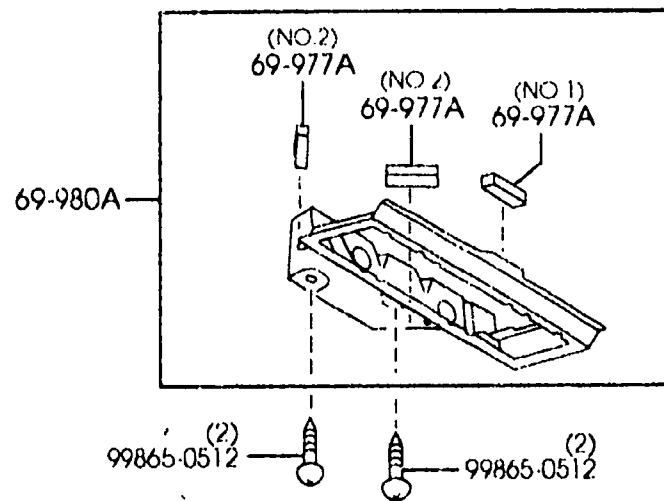

PART NO.	QTY	MODEL/RESTRICTION	MODEL/RESTRICTION	MODEL/RESTRICTION	FROM-TO
69-17CK		BULB, INTERIOR MIRROR	AMPOULE		
99701-6050	2	12V 5W	12V 5W		
69-810		CONSOLE, OVERHEAD	CONSOLE		
BL2A-69-970	1				-1601
03	INT-	BN1 BN2 BN4 LIGHT GRAY	BN1 BN2 BN4 GRIS CLAIR		
80	INT-	BN3 BEIGE	BN3 BEIGE		
*BL2A-69-970A	1				1601-
* 03	INT-	BN1 BN2 BN4 LIGHT GRAY	BN1 BN2 BN4 GRIS CLAIR		
* 80	INT-	BN3 BEIGE	BN3 BEIGE		
69-973		LENS, OVERHEAD CONSOL E	VERRE, CONSOLE AERIEN NE		
GA2L-69-877A	1				
69-977A		STOPPER	PATIN, SUPPORT CONSOL E		
GE4V-69-977	1	(ILLUST. NO.1)			
GE5B-69-977	2	(ILLUST. NO.2)			
69-780A		BRACKET, OVERHEAD CON SOLE	SUPPORT		
GE4V-69-98XD	1				

1601 BJ22\* -480682

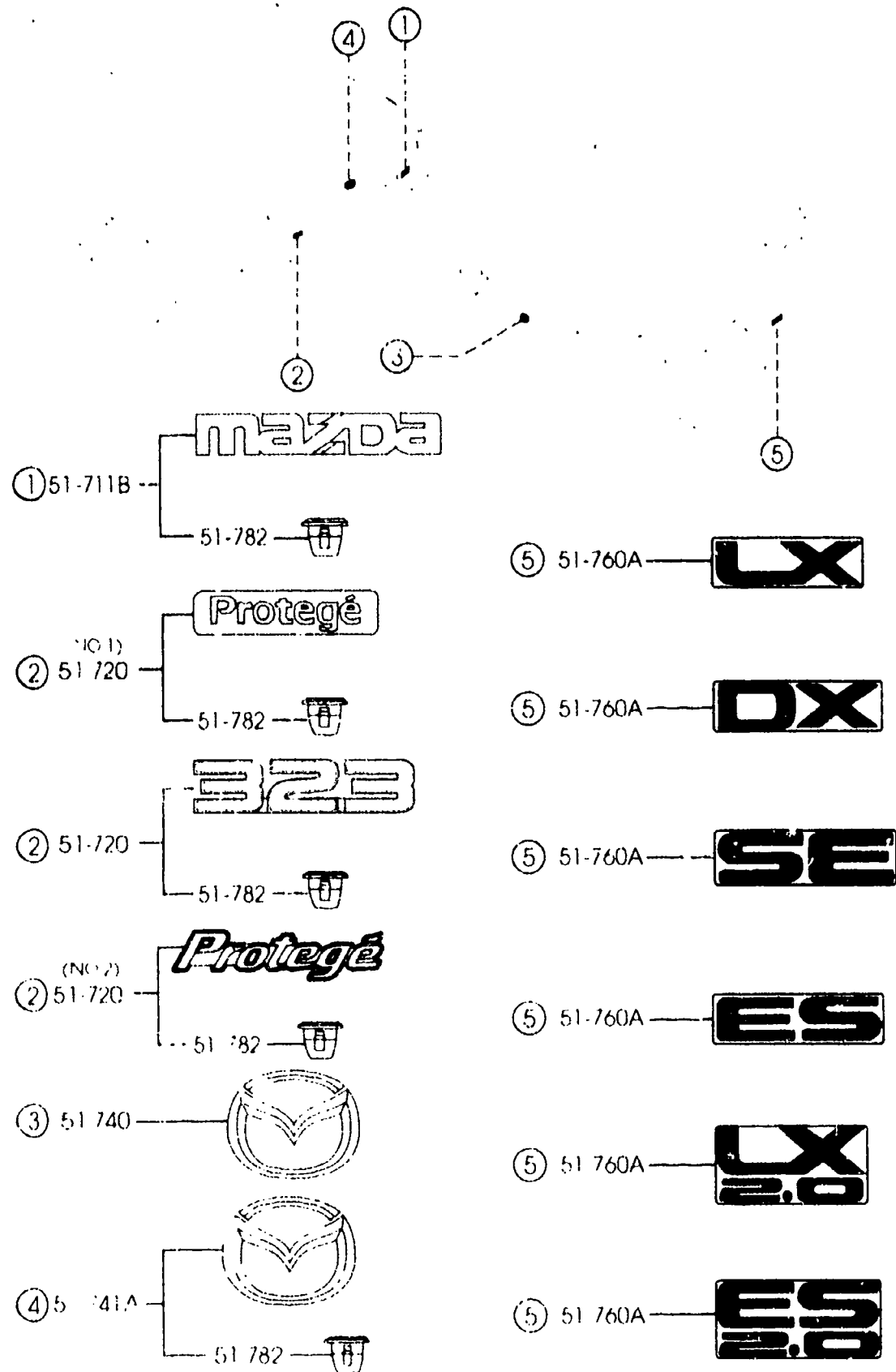

PART NO.	QTY	MODEL/RESTRICTION	MODEL/RESTRICTION	MODEL/RESTRICTION	FROM-TO
51-711B B25D-51-710A	1	ORNAMENT, MAKER NAME-REAR (SPORT SUSP)	ORNEMENT, NOM DE FAB ARR (SUSP. SPORTIVE)		
51-720 BJOE-51-720A	1	ORNAMENT, CAR NAME-REAR (ILLUST. NO.1) (PROTEGE) (SPORT SUSP)	ORNEMENT, NOM DE AUTO ARR (SUSP. SPORTIVE)		
BJ1V-51-720A	1	(323) (SPORT SUSP)	(SUSP. SPORTIVE)		
*BL8E-51-720	1	(ILLUST. NO.2) (PROTEGE) (SPORT SUSP)	(SUSP. SPORTIVE)		1701-
51-740 S41A-51-731A	1	MASCOT, FRONT (SPORT SUSP)	MASCOTTE AV (SUSP. SPORTIVE)		
51-741A B25D-51-730B	1	MASCOT, REAR (SPORT SUSP)	MASCOTTE, AR (SUSP. SPORTIVE)		
51-760A BJOE-51-761A	2	ORNAMENT, GRADE-SIDE (LX)	ORNEMENT, QUALITE-LATERALE		
80	EXT-	A3D A3E HZ 16W 18J 20P 22A 22K 22L 22V 23F 4F 24A 24G 24X 26H GRAY METALLIC	A3D A3E HZ 16W 18J 20P 22A 22K 22L 22V 23F 4F 24A 24G 24X 26H GRIS METALLIQUE		
85	EXT-	23G SILVER METALLIC	23G ARGENT METALLIQUE		
BJOF-51-761A	2	(DX)			
80	EXT-	A3D A3E HZ 16W 18J 20P 22A 22K 22L 22V 23F 4F 24A 24G 24X 26H GRAY METALLIC	A3D A3E HZ 16W 18J 20P 22A 22K 22L 22V 23F 4F 24A 24G 24X 26H GRIS METALLIQUE		
85	EXT-	23G SILVER METALLIC	23G ARGENT METALLIQUE		
BJOG-51-761A	2	(SE)			
80	EXT-	A3D A3E HZ 16W 18J 20P 22A 22K 22L 22V 23F 4F 24A 24G 24X 26H GRAY METALLIC	A3D A3E HZ 16W 18J 20P 22A 22K 22L 22V 23F 4F 24A 24G 24X 26H GRIS METALLIQUE		
85	EXT-	23G SILVER METALLIC	23G ARGENT METALLIQUE		
BJON-51-761A	2	(ES)			
80	EXT-	A3D A3E HZ 16W 18J 20P 22A 22K 22L 22V 23F 4F 24A 24G 24X 26H GRAY METALLIC	A3D A3E HZ 16W 18J 20P 22A 22K 22L 22V 23F 4F 24A 24G 24X 26H GRIS METALLIQUE		

1701 BJ22\* -493151

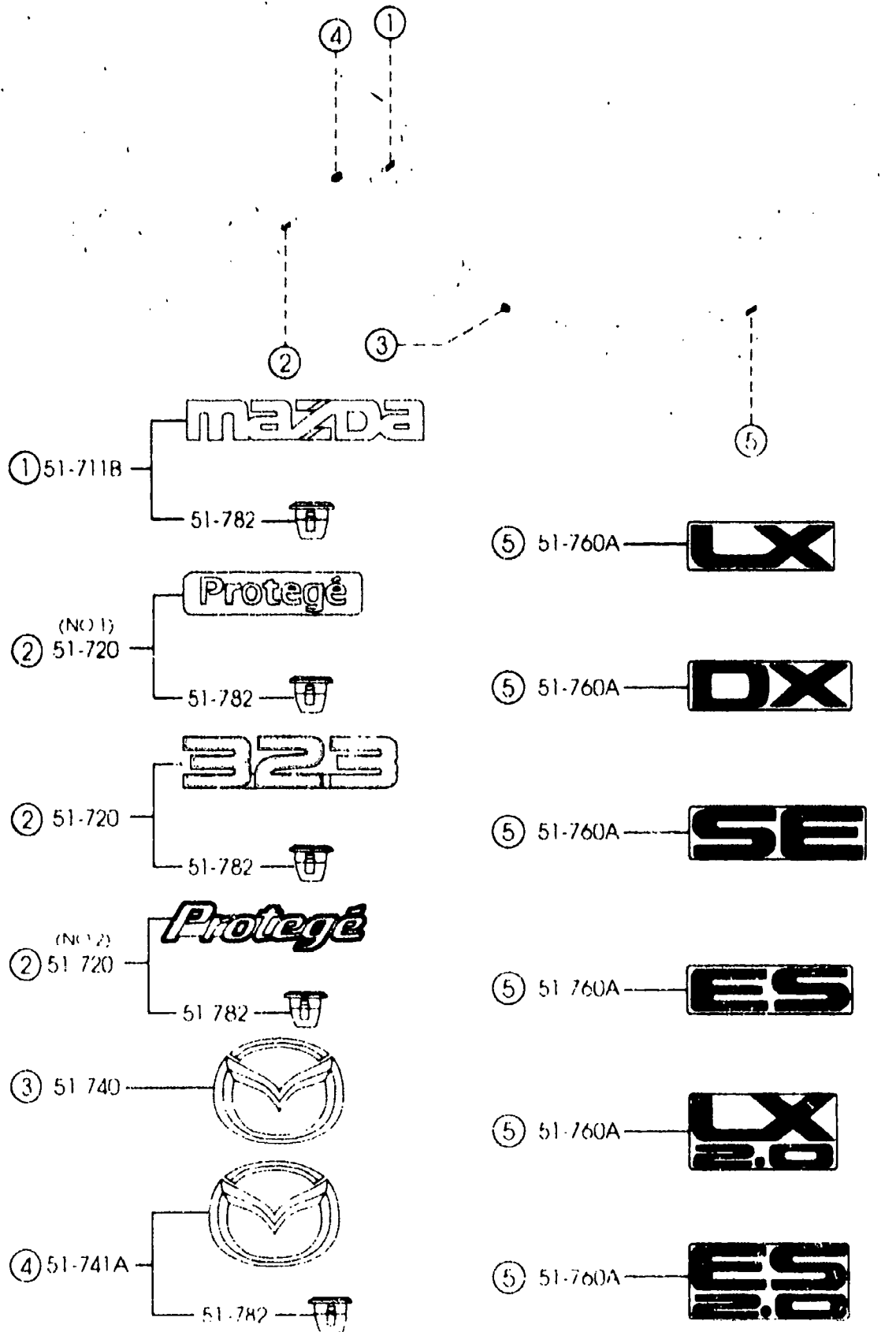

PART NO.	QTY	MODEL/RESTRICTION	MODEL/RESTRICTION	MODEL/RESTRICTION	FROM-TO
CONT'D 85	EXT-	23G SILVER METALLIC	23G ARGENT METALLIQUE		
BL8D-51-761	2	(LX-2,0)			
80	EXT-	A3D A3E HZ 16W 18J 20P 22A 22K 22L 22V 23F 4F GRAY METALLIC	A3D A3E HZ 16W 18J 20P 22A 22K 22L 22V 23F 4F GRIS METALLIQUE		
85	EXT-	23G SILVER METALLIC	23G ARGENT METALLIQUE		
BL8E-51-761	2	(ES-2,0)			
80	EXT-	A3D A3E HZ 16W 18J 20P 22A 22K 22L 22V 23F 4F GRAY METALLIC	A3D A3E HZ 16W 18J 20P 22A 22K 22L 22V 23F 4F GRIS METALLIQUE		
85	EXT-	23G SILVER METALLIC	23G ARGENT METALLIQUE		
51-782		CLIP, TUBULAR	ATTACHE		
LA01-51-958	6				

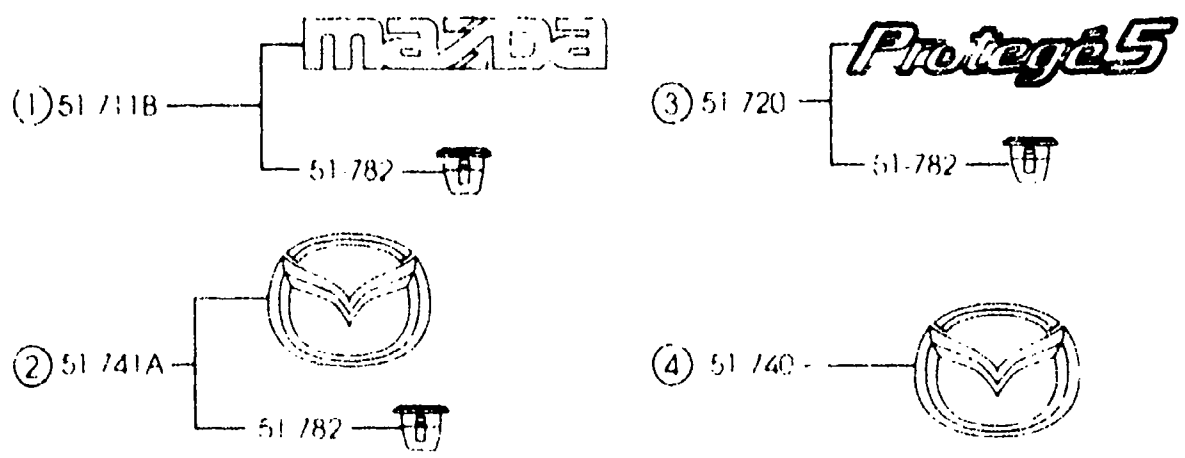
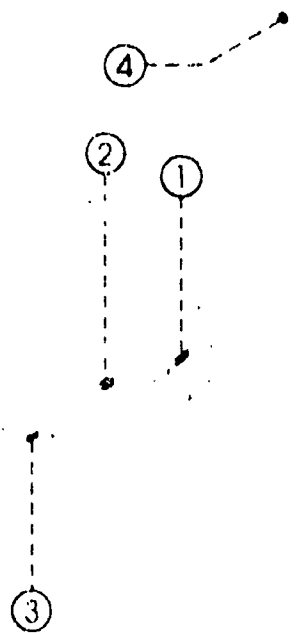

PART NO.	QTY	MODEL/RESTRICTION	MODEL/RESTRICTION	MODEL/RESTRICTION	FROM-TO
51-711B B25R-51-710	1	ORNAMENT, MAKER NAME-REAR	ORNEMENT, NOM DE FAB ARR		
51-720 BN5W-51-720	1	ORNAMENT, CAR NAME-REAR	ORNEMENT, NOM DE AUTO ARR		
51-740 S41A-51-731A	1	MASCOT, FRONT	MASCOTTE AV		
51-741A DC01-51-730A	1	MASCOT, REAR	MASCOTTE .AR		
51-782 LA01-51-958	6	CLIP, TUBULAR	ATTACHE		

5180A COWL & EXTRACTOR GRILLES  
(4-DOOR)

5180A -1 COWL & EXTRACTOR GRILLES  
(4-DOOR)

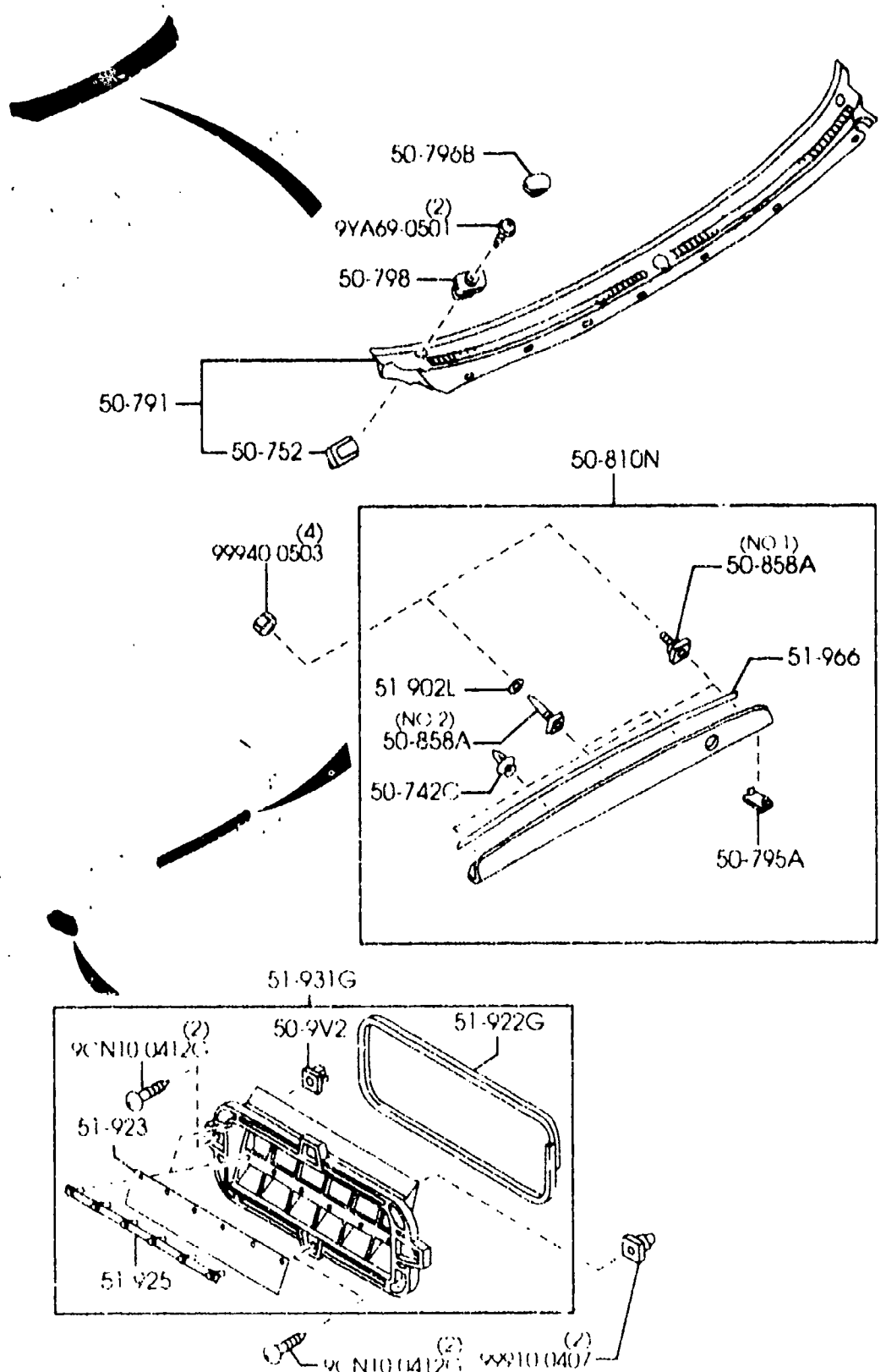

PART NO	QTY	MODEL/RESTRICTION	MODEL/RESTRICTION	MODEL/RESTRICTION	FROM-TO
50-742C		CLIP	ATTACHE		
G043-50-742	1				
50-752		CLIP	ATTACHE		
GA7B-50-797A	5				
50-791		GRILLE,COWL	PROTECTION, RADIATEUR		
BJ0J-50-790A	1				
50-795A		CAP	BOUCHON		
B25D-50-819B	1	(RR GARNISH-B.COLOR)			
HZ	EXT-	HZ SUNBURST YELLOW	HZ JAUNE BRULE		
08	EXT-	16W 24X BLACK MC	16W 24X MICA NOIR		
09	EXT-	A3D PURE WHITE	A3D BLANC PURE		
10	EXT-	A3E CLASSIC RED CLE	A3E ROUGE ETERNEL		
15	EXT-	22K PASSION RED MC	22K ROUGE PASSION METALL		
27	EXT-	23F GALAXY GOLD M.	23F OR GALAXIE M.		
4F	EXT-	4F CHAMPAGNE SILVER MC	4F ARGENT CHAMPAGNE MICA		
46	EXT-	18J GRACE GREEN MC	18J VERT GRACIEUX MC		
52	EXT-	24A STARRY BLUE MC	24A BLUE ETOILE MICA		
67	EXT-	22V 24G SUNLIGHT SILVER M	22V 24G ARGENT METALL. SOLEIL		
91	EXT-	23G ORIENT GREEN MC	23G VERT ORIENT MC		
*BK2H-50-819	1	(RR GARNISH-BRIGHT)			1701-
50-796B		CAP	BOUCHON		
E016-50-796	2				
50-798		SCREW,GROMMET	VIS,BAGUE		
BJ0J 50-798	2				
50-810N		GARNISH,LIFT GATE	GARNITURE,PORTE LEVAGE		
B25F-50-810B	1	(RR GARNISH-B.COLOR)			
HZ	EXT-	HZ SUNBURST YELLOW	HZ JAUNE BRULE		
08	EXT-	16W 24X BLACK MC	16W 24X MICA NOIR		
09	EXT-	A3D PURE WHITE	A3D BLANC PURE		

1701 BJ22\* -493151

5180A COWL & EXTRACTOR GRILLES  
(4-DOOR)

5180A -2 \* COWL & EXTRACTOR GRILLES  
(4-DOOR)

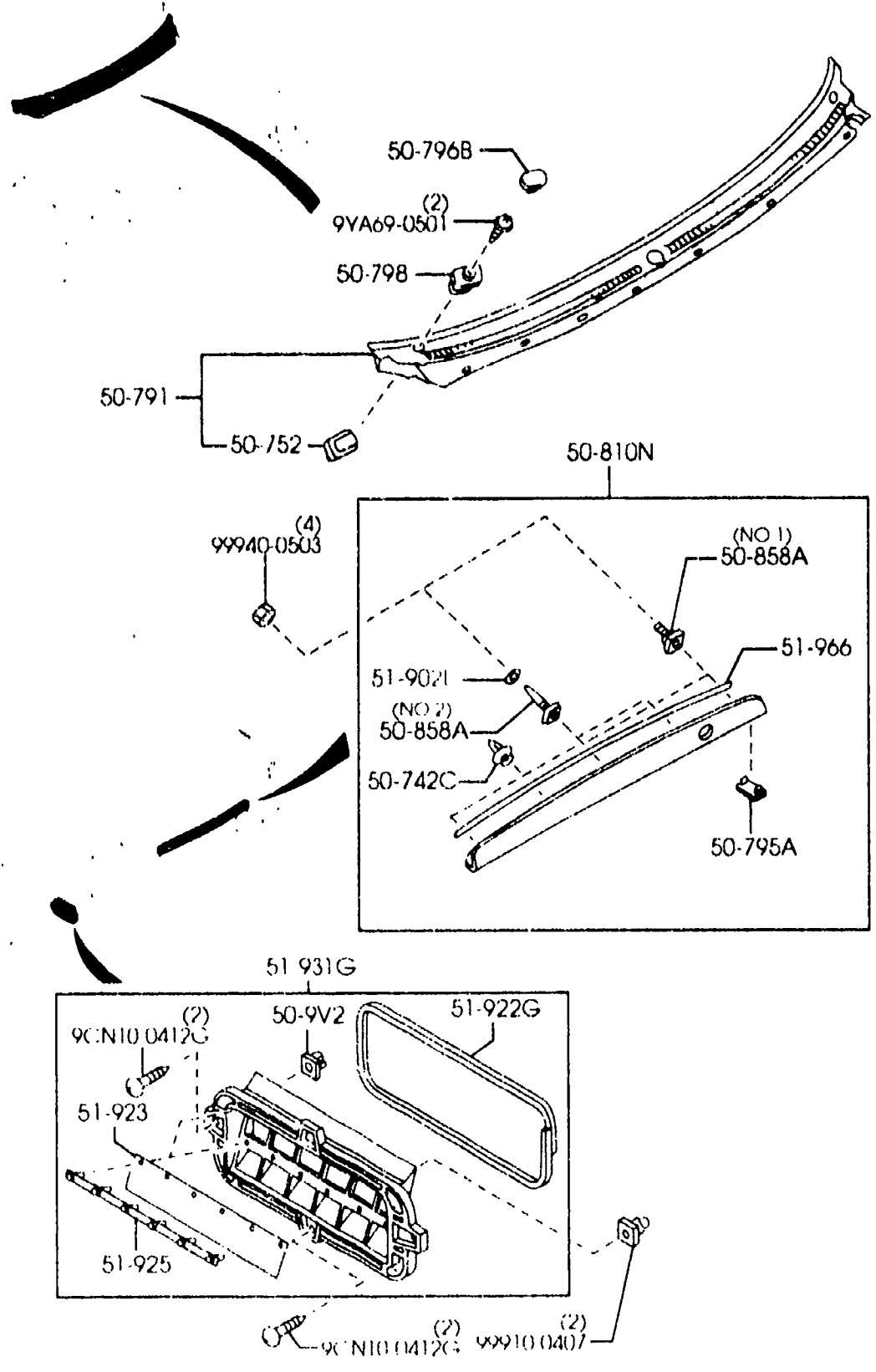

PART NO.	QTY	MODEL/RESTRICTION	MODEL/RESTRICTION	MODEL/RESTRICTION	FROM-TO
CONT'D					
10	EXT-	A3E CLASSIC RED CLE	A3E ROUGE ETERNEL		
15	EXT-	22K PASSION RED MC	22K ROUGE PASSION METALL		
27	EXT-	23F GALAXY GOLD M.	23F OR GALAXIE M.		
4F	EXT-	4F CHAMPAGNE SILVER MC	4F ARGENT CHAMPAGNE MICA		
46	EXT-	18J EXCELLENT GREEN MC	18J VERT EXCELLENT MC		
52	EXT-	24A STARRY BLUE MC	24A BLUE ETOILE MICA		
67	EXT-	22V 24G SUNLIGHT SILVER M	22V 24G ARGENT METALL. SOLEIL		
91	EXT-	23G ORIENT GREEN MC	23G VERT ORIENT MC		
*BK2H-50-810	1	(RP. GARNISH-B. IGH)			1701-
50-858A		COLLAR, REAR FINISHER	COLLET, FINISSEUR ARR. IERE.		
BW1N-51-SF4	2	(ILLUST. NO.1)			
M001-51-3F4	2	(ILLUST. NO.2)			
50-9V2		GROMMET, SCREW-ROLL B. GARN	BAGUE, VIS-GARNIT. BA RRE.		
B250-50-9V2	2				
51-902L		GASKET	JOINT		
G030-51-914	2				
51-922G		GASKET, CHAMBER-EXTRACTOR	JOINT		
GE4T-51-922	1				
51-923		VALVE, EXTRACT CHAMBER	SOUPAPE, CHAMBRE EXTRACT.		
GE4T-51-923	2				
51-925		RETAINER, CHAMBER-EXTRACTOR	RESSORT ARRET-CHAM-EXTRT		
GE4T-51-924	2				
51-931G		CHAMBER, EXTRACTOR	CHAMBRE, EXTRACTEUR		
C001-51-920B A (C001-51-920D)	1				-1401
C001-51-920D	1				1401-
51-966		PROTECTOR	PROTECTEUR		
B25D-50-814A	1				

1401 BJ22\* -452569  
1701 BJ22\* -493151

5180B COWL & EXTRACTOR GRILLES  
(5-DOOR)

5180B -1 COWL & EXTRACTOR GRILLES  
(5-DOOR)

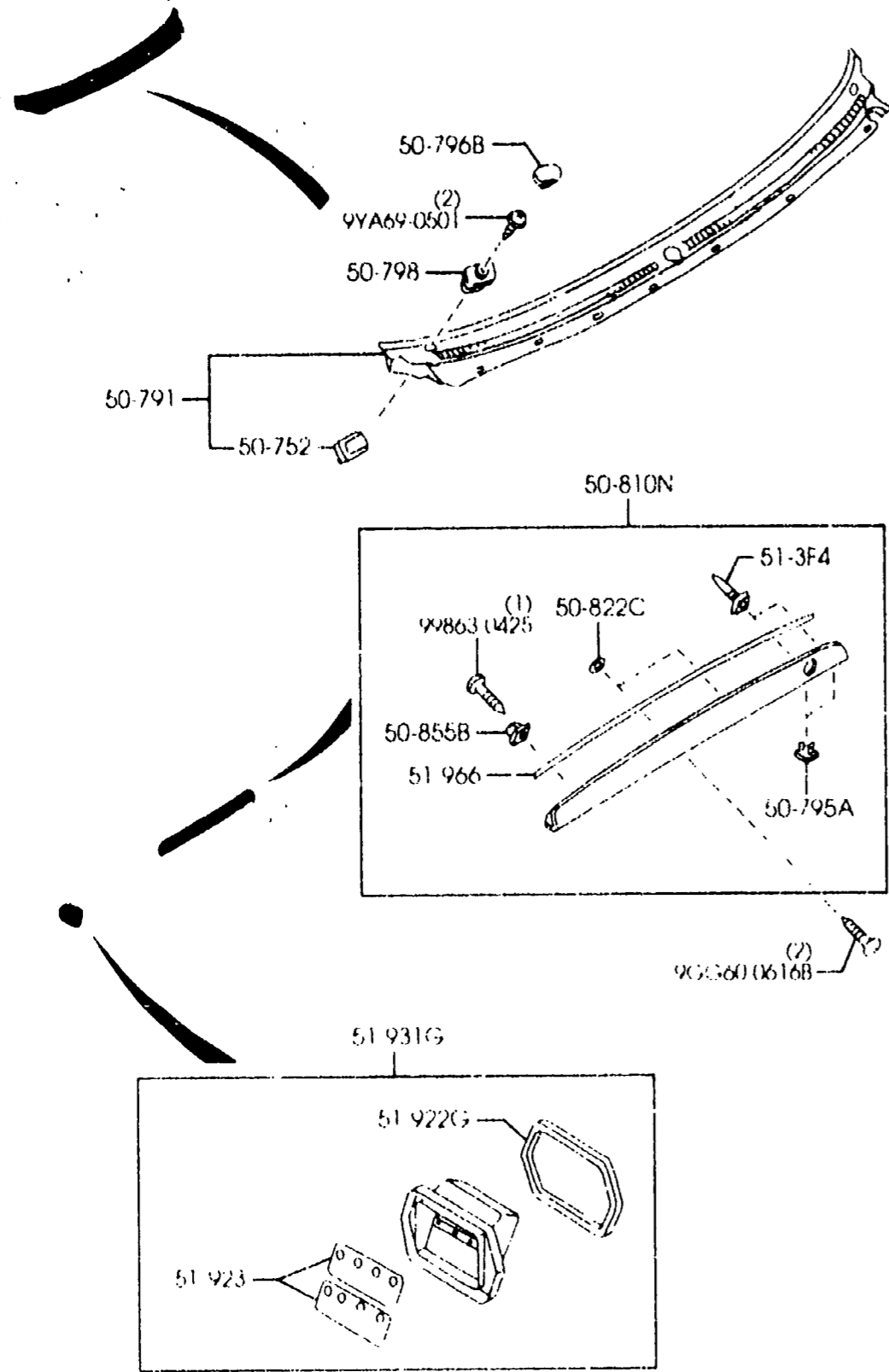

PART NO.	QTY	MODEL/RESTRICTION	MODEL/RESTRICTION	MODEL/RESTRICTION	FROM-TO
50-752		CLIP	ATTACHE		
GA7B-50-797A	5				
50-791		GRILLE,COWL	PROTECTION, RADIATEUR		
BJ0J-50-790A	1				
50-795A		CAP	BOUCHON		
B25R-50-819B	2				
HZ	EXT-	HZ SUNBURST YELLOW	HZ JAUNE BRULE		
08	EXT-	16W 24X BLACK MC	16W 24X MICA NOIR		
09	EXT-	A3D PURE WHITE	A3D BLANC PURE		
10	EXT-	A3E CLASSIC RED CLE	A3E ROUGE ETERNEL		
46	EXT-	18J GRACE GREEN MC	18J VERT GRACIEUX MC		
50	EXT-	22A SUPREME BLUE MC	22A ROUGE NEUF		
67	EXT-	22V 24G SUNLIGHT SILVER M	22V 24G ARGENT METALL. SOLEIL		
50-796B		CAP	BOUCHON		
E016-50-796	2				
50-798		SCREW,GROMMET	VIS,BAGUE		
BJ0J-50-798	2				
50-810N		GARNISH,LIFT GATE	GARNITURE,PORTE LEVAGE		
B25R-50-810B	1				
HZ	EXT-	HZ SUNBURST YELLOW	HZ JAUNE BRULE		
08	EXT-	16W 24X BLACK MC	16W 24X MICA NOIR		
09	EXT-	A3D PURE WHITE	A3D BLANC PURE		
10	EXT-	A3E CLASSIC RED CLE	A3E ROUGE ETERNEL		
46	EXT-	18J GRACE GREEN MC	18J VERT GRACIEUX MC		
50	EXT-	22A SUPREME BLUE MC	22A ROUGE NEUF		
67	EXT-	22V 24G SUNLIGHT SILVER M	22V 24G ARGENT METALL. SOLEIL		
50-822C		GASKET	JOINT		
B22H-50-818	2				
50-855B		FASTENER	AGRAFE		
B173-50-852A	1				

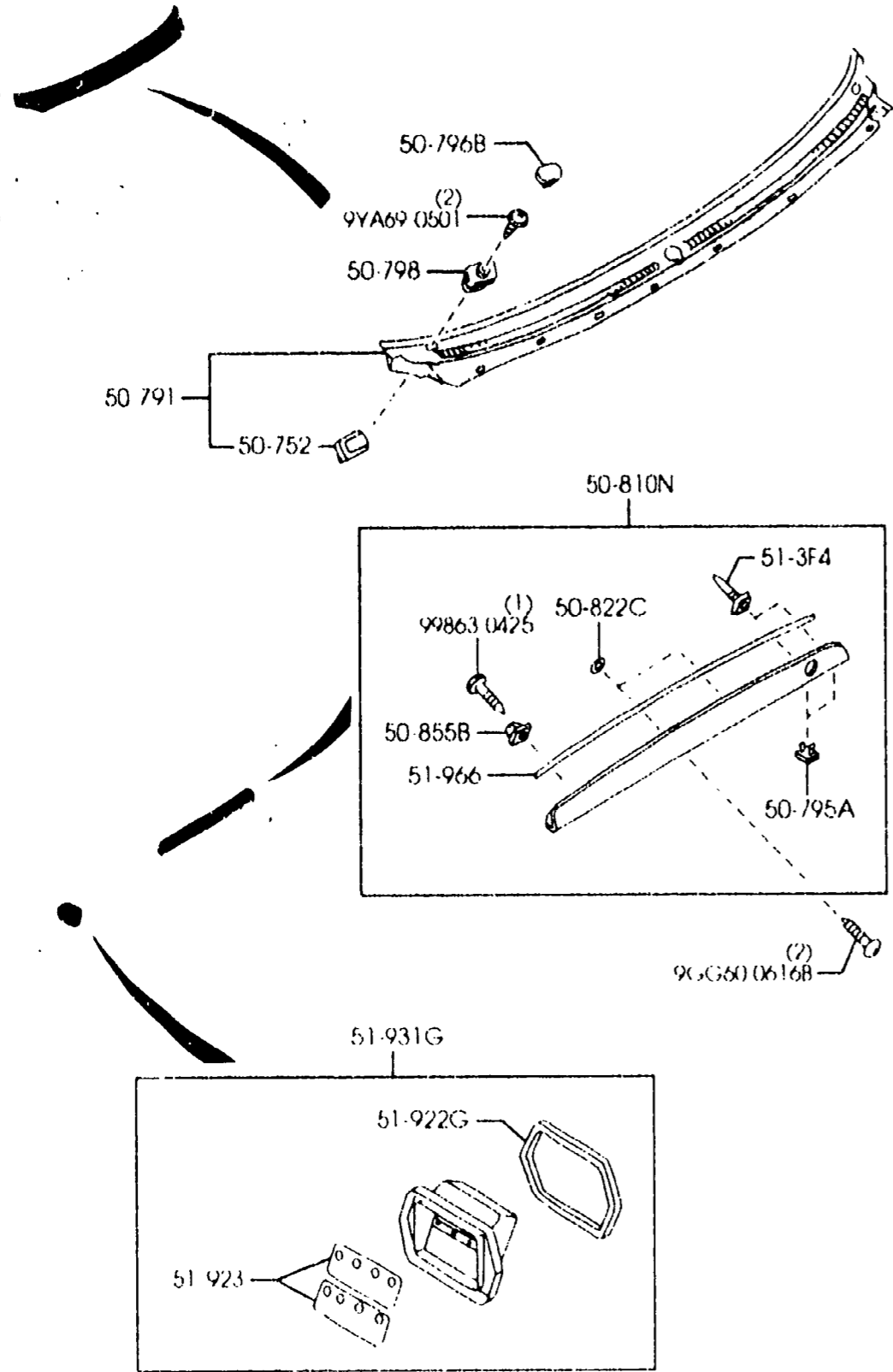

PART NO	QTY	MODEL/RESTRICTION	MODEL/RESTRICTION	MODEL/RESTRICTION	FROM TO
51-3F4		COLLAR	BAGUE		
B25R-51-3F4	2				
51-922G		GASKET, CHAMBER-EXTRACTOR	JOINT		
E016-51-922	2				
51-923		VALVE, EXTRACT CHAMBER	SOUPAPE, CHAMBRE EXTRACT.		
E016-51-923C	4				
51-931G		CHAMBER, EXTRACTOR	CHAMBRE, EXTRACTEUR		
E016-51-920G	2				
51-966		PROTECTOR	PROTECTEUR		
B25R-50-814A	1				



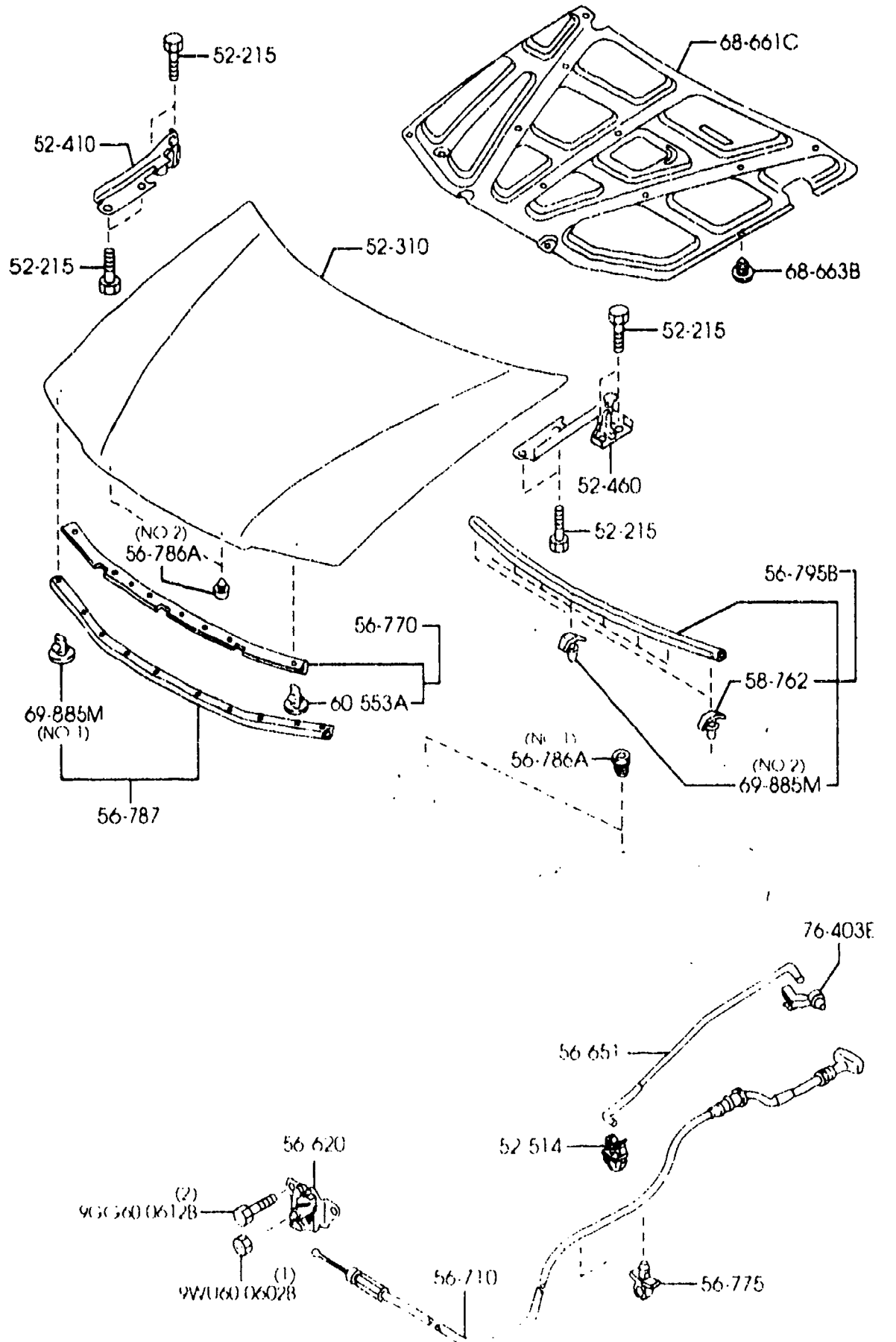

PART NO	QTY	MODEL/RESTRICTION	MODEL/RESTRICTION	MODEL/RESTRICTION	FROM-TO
52-215		BOLT, BONNET HINGE	BOULON DE CHARNIERE		
GA2A-52-403A	8				
52-310		BONNET	CAPOT, AV		
B30D-52-310C	1				
52-410		HINGE(R), BONNET	CHARNIERE(D), CAPOT		
B25D-52-410A	1				
52-460		HINGE(L), BONNET	CHARNIERE(G), CAPOT		
B25D-52-420A	1				
52-514		HOLDER, ROD	SUPPORT, TRINGLE		
G030-56-693A	1				
56-620		LOCK, BONNET	VERROUILLAGE CAPOT		
BL4C-56-620	1				
56-651		STAY, LOCK-BONNET	SUPPORT, VERROU-CAPUCHON		
B25D-56-651	1				
56-710		WIRE, RELEASE-BONNET	CABLE DE DECLENCHEMENT		
B25D-56-720	1				
56-770		RUBBER(C), SEAL-BONNET	CAOUTCHOUC(G), JOINT-CAPU.		
B25D-56-750B	1				
56-775		CLIP, WIRE-BONNET	PINCE, FIL-CAPUCHON. D ECHAR		
D001-56-731	2				
56-786A		RUBBER, CUSHION	SILENT BLOC		
BC1M-56-786	2 (ILLUST. NO.1)				
H043-56-786	2 (ILLUST. NO.2)				
56-787		WEATHERSTRIP, BONNET	PROFILE D'ETANCH., CAPOT		
B30D-56-770A	1				
56-795B		WEATHERSTRIP, BONNET-REAR	BURRELET, CAPOT-MOTEUR AR		
B30D-56-760	1				

3-J 7

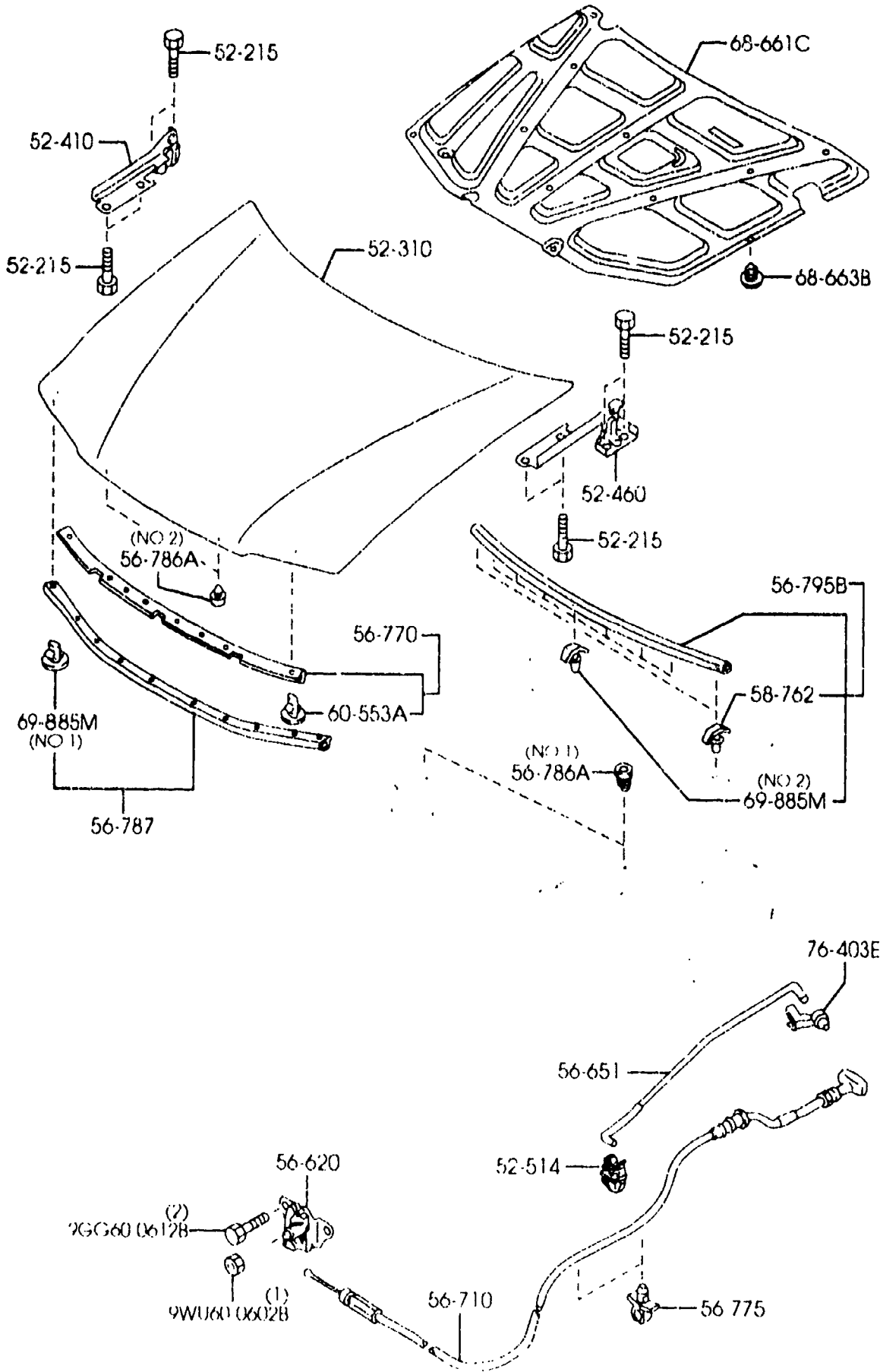

PART NO.	QTY	MODEL/RESTRICTION	MODEL/RESTRICTION	MODEL/RESTRICTION	FROM-TO
58-762		FASTENER	AGRAFE		
G031-58-762	2				
60-553A		RIVET	RIVET		
UB39-56-741A	9				
68-661C		INSULATOR, BONNET	INSOLATEUR, CAPOT		
B25N-56-681H	1				
68-663B		FASTENER, BONNET	AGRAFE, CAPOT		
GA2A-56-694	14				
69-885M		FASTENER, SEAL RUBBER	AGRAFE,		
M01A-56-741	13	(ILLUST. NO.1)			
T001-56-742	7	(ILLUST. NO.2)			
76-403E		HOLDER, ROD	SUPPORT, TRINGLE		
B092-52-518	1				

3-K 7

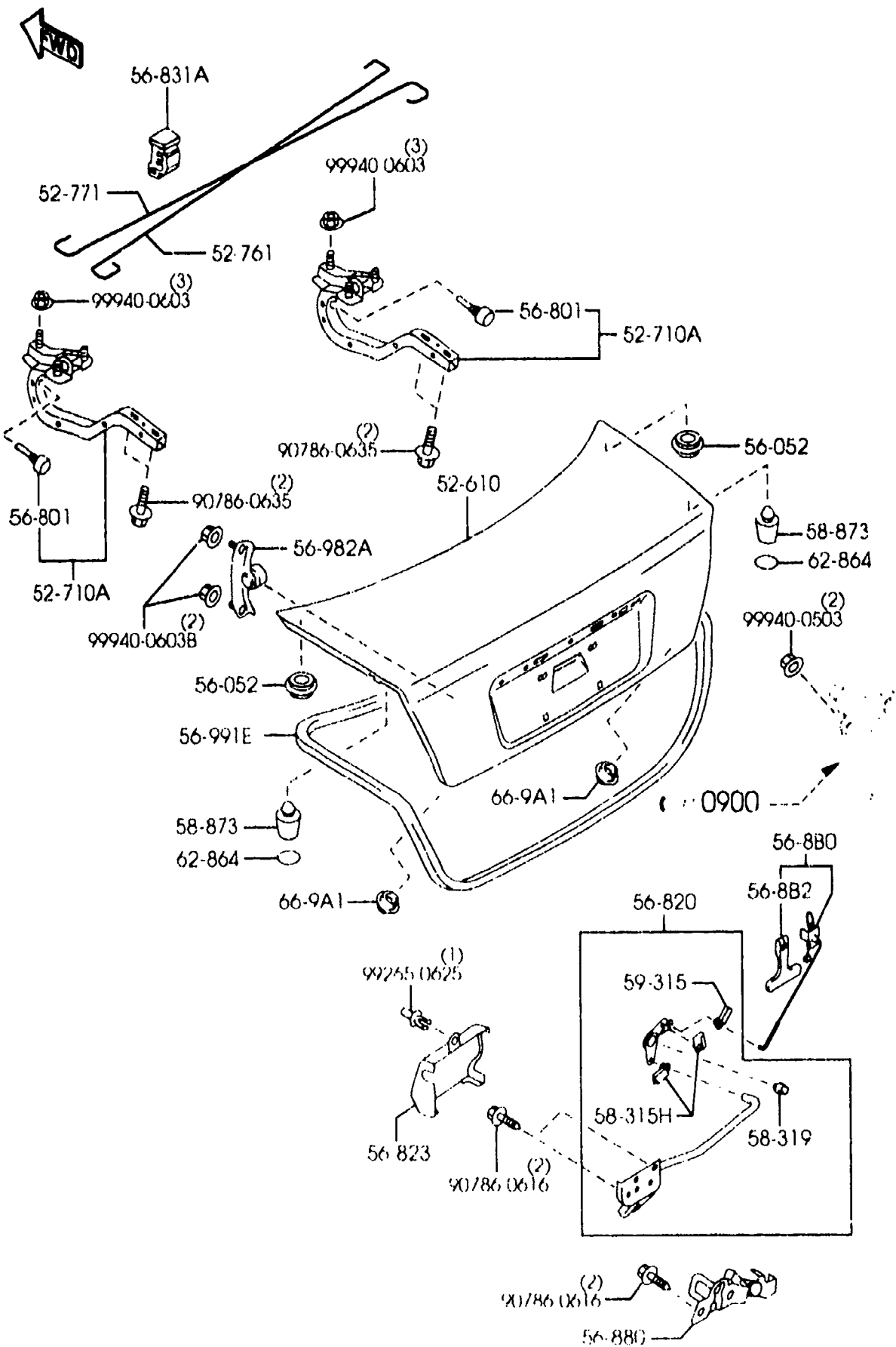

PART NO.	QTY	MODEL/RESTRICTION	MODEL/RESTRICTION	MODEL/RESTRICTION	FRM-TU
52-610		LID, TRUNK	COUVERCLE DE MALLE		
BJOE-52-610B	1	(W/O RR. SPOILER)			
BJOF-52-610	1	(W/RR. SPOILER)			
52-710A		HINGE, TRUNK LID	CHARNIERE,		
B25D-52-710C	2				
52-761		SPRING(R), BALANCE	RESSORT (D), DE COMPENSAT		
B25D-52-791C	1	(W/O RR. SPOILER) (SPORT SUSP)	(SUSP. SPORTIVE)		
B25E-52-791C	1	(W/RR. SPOILER) (SPORT SUSP)	(SUSP. SPORTIVE)		
*BNYH-52-791	1	(MPS SUSP)	(SUSP. MPS)		1401-
52-771		SPRING(L), BALANCE	RESSORT (G), DE COMPENSAT		
B25D-52-792C	1	(W/O RR. SPOILER) (SPORT SUSP)	(SUSP. SPORTIVE)		
B25E-52-792C	1	(W/RR. SPOILER) (SPORT SUSP)	(SUSP. SPORTIVE)		
*BNYH-52-792	1	(MPS SUSP)	(SUSP. MPS)		1401-
56-052		PLUG, DRAIN	BOUCHON DE V'DANGE		
B092-56-052	2	D=12MM	D=12MM		
56-880		CABLE, RELEASE	CABLE DECLENCHEUR		
BJOE-56-880C	1				
56-882		HANDLE, RELEASE	MANETTE, DECHARGE		
BJOE-56-882B	1				
56-801		CUSHION, LID HINGE	COUSSIN, CHARNIERE DE COUVERCLE		
GJ21-56-802A	2				
56-820		LOCK, LID	VERROUILLAGE COFFRE		
BL8D-56-820	1	(W/O LUGGAGE ROOM LAMP)			
BL8E-56-820	1	(W/LUGGAGE ROOM LAMP)			
56-823		PROTECTOR, LOCK-TRUNK LID	PROTECTEUR, VERR.-POR. COF		
BC1M-56-823A	1				

1401 BJ22\* -452569

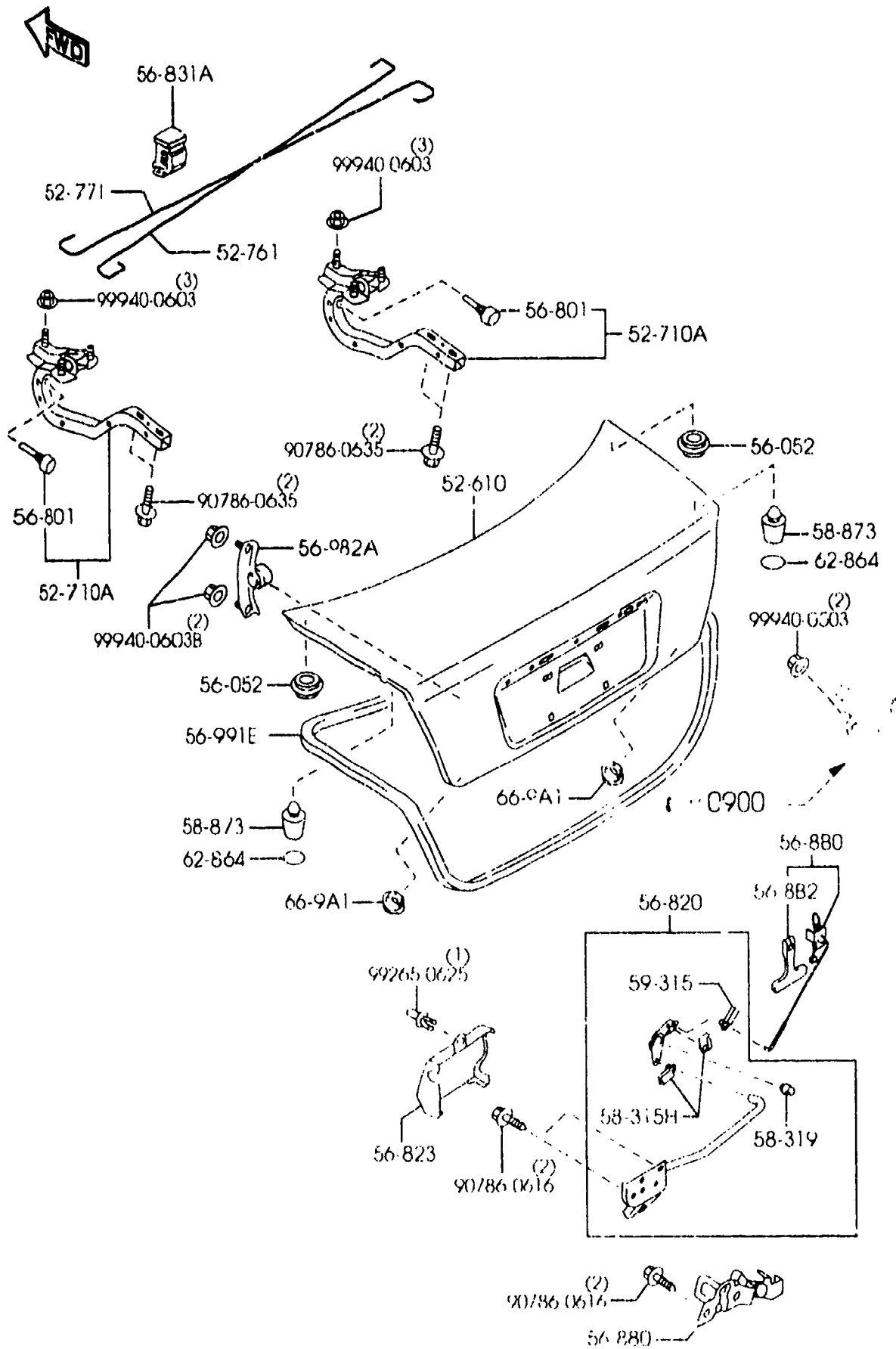

PART NO.	QTY	MODEL/RESTRICTION	MODEL/RESTRICTION	MODEL/RESTRICTION	FROM-TO
56-831A		CLIP	ATTACHE		
BC1M-56-894C	1				
56-880		STRIKER, LID	GACHE, COFFRE		
B25D-56-840A	1				
56-982A		LID, DYNAMIC DAMPER	CAPOT, AMORTISS. DYNAMIQUE		
B25D-56-982B	1 (W/O RR. SPOILER)				
56-991E		WEATHERSTRIP, LID	PROFILE DISTANCH.,		
B25D-56-951B	1				
58-315H		CLIP	CLIP		
G030-58-315	2				
58-319		BUSH	BUSELURE		
H001-58-318	1				
58-873		RUBBER, CUSHION-F DOOR UP.	CAOUT. COUSS PORTE A V SUP		
KA01-58-873A	2				
59-315		CLIP	ATTACHE		
G030-59-315	1				
62-864		TAPE, PROTECTOR-STRIPPER	BANDE, PROTECT. - PASTILLE		
G043-62-864A	2				
66-9A1		COVER, HOLE-ANTENNA	COUVERCLE, TROU-ANTENNE		
KA01-66-9A1	2				

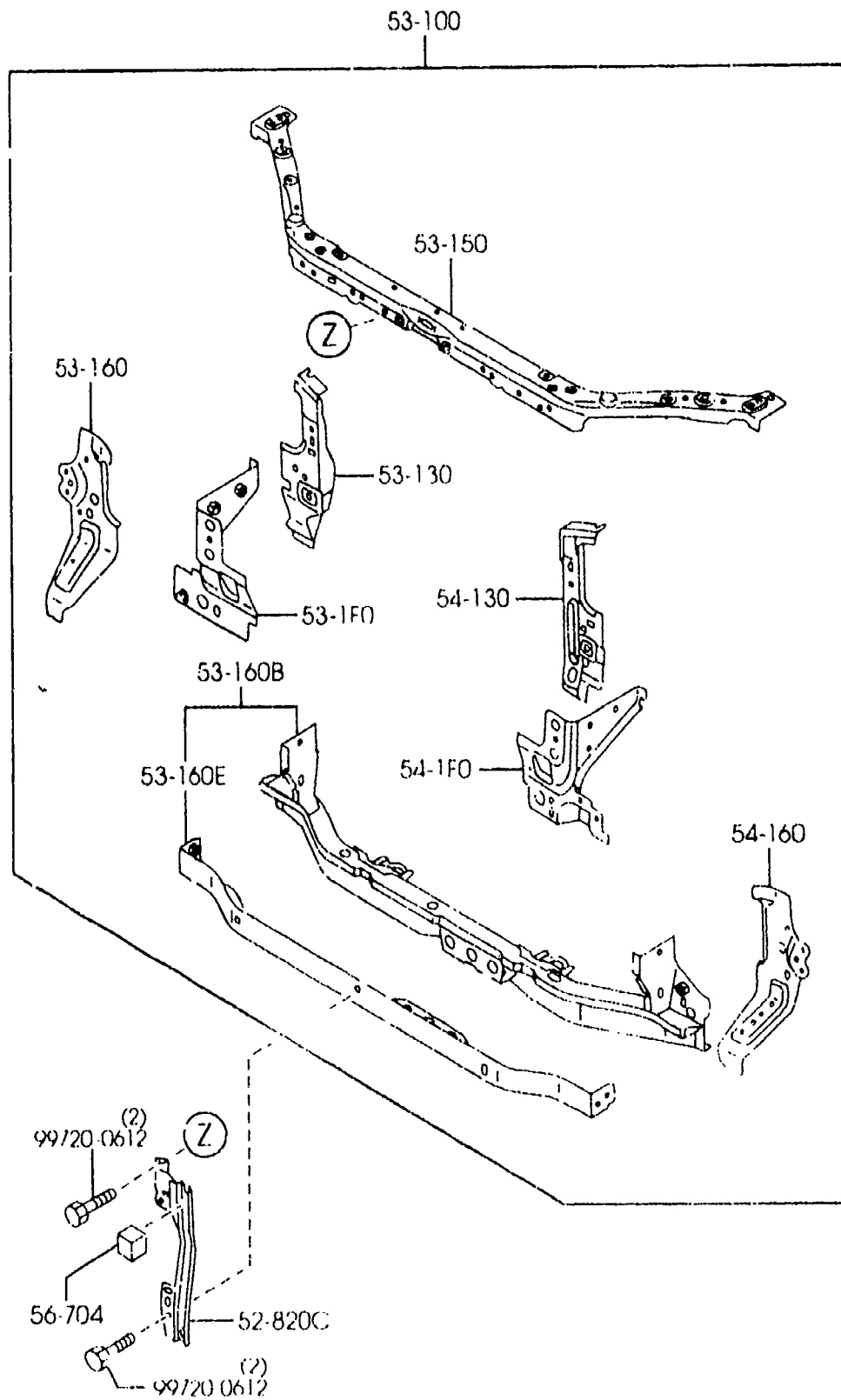

PART NO.	QTY	MODEL/RESTRICTION	MODEL/RESTRICTION	MODEL/RESTRICTION	FROM TO
52-820C		STAY, LOCK	ETAI DE BLOCAGE		
B25D-52-15YD	1				
53-1F0		SIDE NO. 1(R), CROSS	COTE NO. 1(D), CROIX		
BJ0J-53-1F0B	1				
53-100		PANEL, SHROUD	TOLE DE RADIATEUR		
BL2A-53-100C	1				
53-130		STAY(R), SHROUD-SIDE	TRAVERSE(D), COTE-DEFLECTE		
BJ0J-53-130	1				
53-150		MEMBER, SHROUD-UPPER	PLAQUE SUP., DEFLECTEUR		
BJ0J-53-150D	1				
53-160		PANEL(R), SHROUD	PANNEAU(D), DEFLECTEUR		
BL2A-53-120	1				
53-160B		MEMBER, CROSS	TRAVERSE		
B25D-53-16XA	1				
53-160E		MEMBER NO. 1, CROSS	TRAVERSE NO 1		
B25D-53-160	1				
54-1F0		SIDE NO. 1(L), CROSS	COTE NO. 1(G), CROIX		
BJ0J-54-1F0	1				
54-130		STAY(L), SHROUD-SIDE	TRAVERSE(G), COTE-DEFLECTE		
BJ0J-54-130	1				
54-160		PANEL(L), SHROUD	PANNEAU(G), DEFLECTEUR		
BL2A-54-120	1				
56-704		PROTECTOR	PROTECTEUR		
B25D-56-395	1 (4DR)		(4PRTS)		



5320A FENDER & WHEEL APRON PANELS  
(4-DOOR)

5320A -1 FENDER & WHEEL APRON PANELS  
(4-DOOR)

★ This part is not serviced.

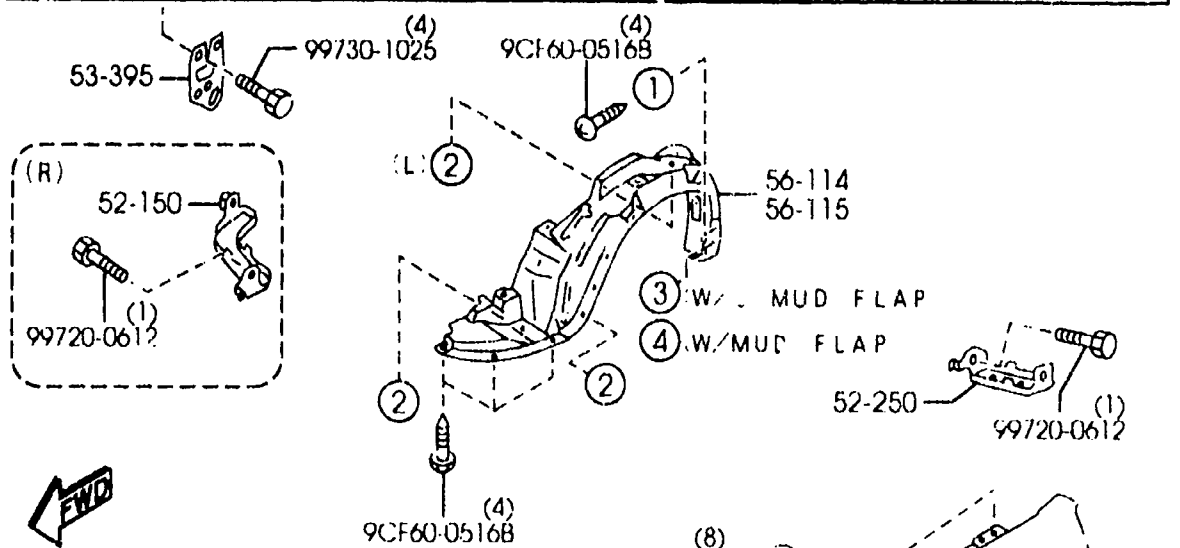
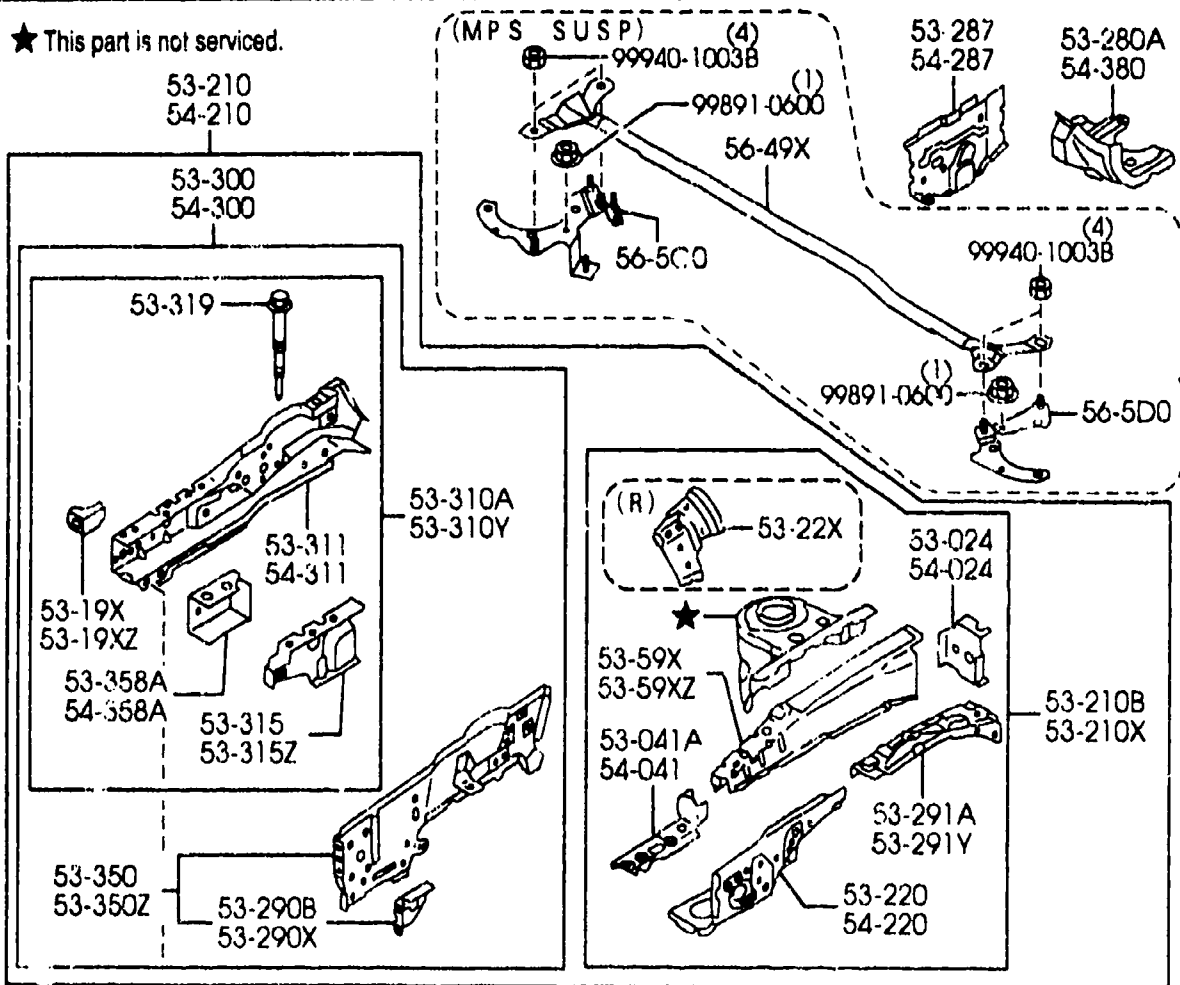

①	②	③	④
56-055A	56-145C	69-885D	76-724

AUBA09

(2B58900)

PART NO.	QTY	MODEL/RESTRICTION	MODEL/RESTRICTION	MODEL/RESTRICTION	FROM-TO
52-110		PANEL(R), FENDER-FRT.	AILE AVANT (D)		
BL8D-52-111B	1	(SPORT SUSP)	(SUSP. SPORTIVE)		
B30D-52-111B	1	(MPS SUSP)	(SUSP.MPS)		
52-150		STAY(R), FENDER	ETAI(D), AILE		
B25D-52-140A	1				
52-210		PANEL(L), FENDER-FRT.	AILE AVANT (G)		
BL8D-52-211B	1	(SPORT SUSP)	(SUSP. SPORTIVE)		
B30D-52-211B	1	(MPS SUSP)	(SUSP.MPS)		
52-250		STAY(L), FENDER	ETAI(G), AILE		
B25D-52-240A	1				
53-024		GUSSET(R), WHEEL APRON	GOUSSET(D), TABLIER R		
B25D-53-263	1		QUES		
53-041A		REINF.(R), WHEEL APRON	RENFORT(D), TABLIER R		
BJ0J-53-272A	1	N-UP.	QUE-S		
53-19X		BRKT(R), BUMPER-F. FR	SUPPORT(D), AMORT.-CH		
B25D-53-335A	1	AME	AS.AV		
53-19XZ		BRKT(L), BUMPER-F. FR	SUPPORT(G), AMORT.-CH		
B25D-54-335A	1	AME	AS.AV		
53-210		PANEL(R), APRON & FRA	PASSAGE DE ROUE (D)		
B2YD-53-20YB	1	ME			
53-210B		PANEL(R), WHEEL APRON	PANNEAU(D), TABLIER R		
B2YD-53-21YC	1	QUE			
53-210X		PANEL(L), WHEEL APRON	PANNEAU(G), TABLIER R		
B2YD-54-21YF	1	QUE			
53-22X		REINF-NO.3, ENG. MTG.	RENFORT NO.3 MONTAG		
BL2A-53-22X	1		MOTEU		
53-220		PANEL(R), WHEEL APRON	PANNEAU(AV.D), TABLIE		
BJ0J-53-220B	1	FRT	R		

CAT. AUBA09-02

2001-07

5320A FENDER & WHEEL APRON PANELS (4-DOOR)

5320A -2 FENDER & WHEEL APRON PANELS (4-DOOR)

★ This part is not serviced.

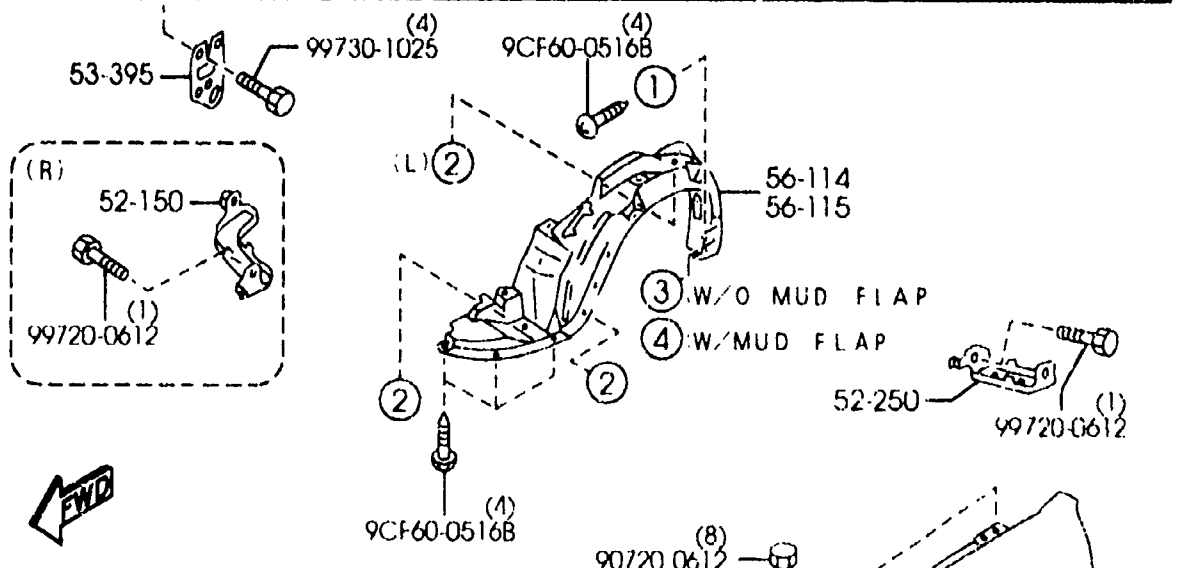
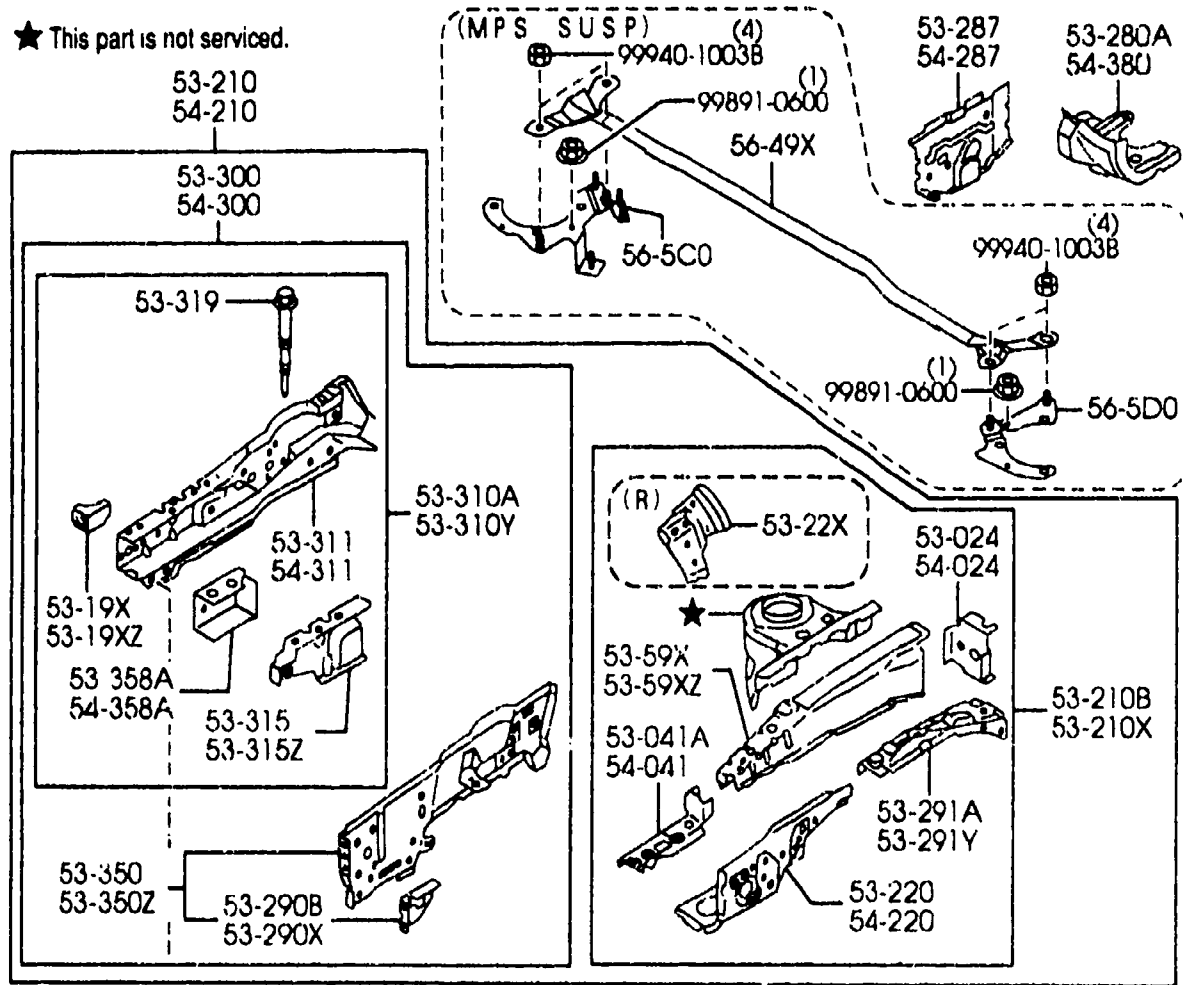

①	②	③	④
56-055A	56-145C	69-885D	76-724

AUBA09

(2B58900)

PART NO.	QTY	MODEL/RESTRICTION	MODEL/RESTRICTION	MODEL/RESTRICTION	FROM-TO
53-280A	1	FRAME(R), FRONT-REAR	CADRE(D), AV-AR		
GA5R-53-390F	1				
53-287	1	REINF.(R), COWL SIDE PANEL	REINF.(D), CAPOT PANN .COTE		
B25D-53-281	1				
53-290B	1	BRKT(R), BUMPER-WHL A PRON	SUPPORT(D), AMORT.-TA B.ROU		
B25D-53-336	1				
53-290X	1	BRKT(L), BUMPER-WHL A PRON	SUPPORT(R), AMORT.-TA B.ROU		
B25D-54-336	1				
53-291A	1	REINF.(R), WHL APRON-LOW.	RENFORT(D), TABL. ROU E-INF		
GE4T-53-270B	1				
53-291Y	1	REINF.(L), WHL APRON-LOW.	RENFORT(G), TABL. ROU E-INF		
GE4T-54-270D A (GE4T-54-270E)	1				
GE4T-54-270E	1				
53-300	1	FRAME(R), SIDE-FRONT	CADRE LATERAL AV(D)		
B25D-53-31XE	1				
53-310A	1	FRAME(R), SIDE-INNER	CADRE LATERAL INT.(D)		
B25D-53-310D	1				
53-310Y	1	FRAME(L), SIDE-INNER	CADRE LATERAL INT.(G)		
B25D-54-310C	1				
53-311	1	FRAME(R), INNER	CADRE(D), INT.		
B25D-53-311A	1				
53-315	1	REINF.(R), FRAME-FRT SIDE	RENFORT(D), CHASSIS-A UANT.		
B25D-53-35Y	1				
53-315Z	1	REINF.(L), FRAME-FRT SIDE	RENFORT(D), CHASSIS-A UANT		
B25D-54-35Y	1				
53-319	2	BOLT, MOUNTING	BOULON, MONTAGE-MEMBR E		
B25D-53-317	2				

1601 BJ22\* -400682

CAT. AUBA09-02

2001-07

5320A FENDER & WHEEL APRON PANELS (4-DOOR)

5320A -3 FENDER & WHEEL APRON PANELS (4-DOOR)

★ This part is not serviced.

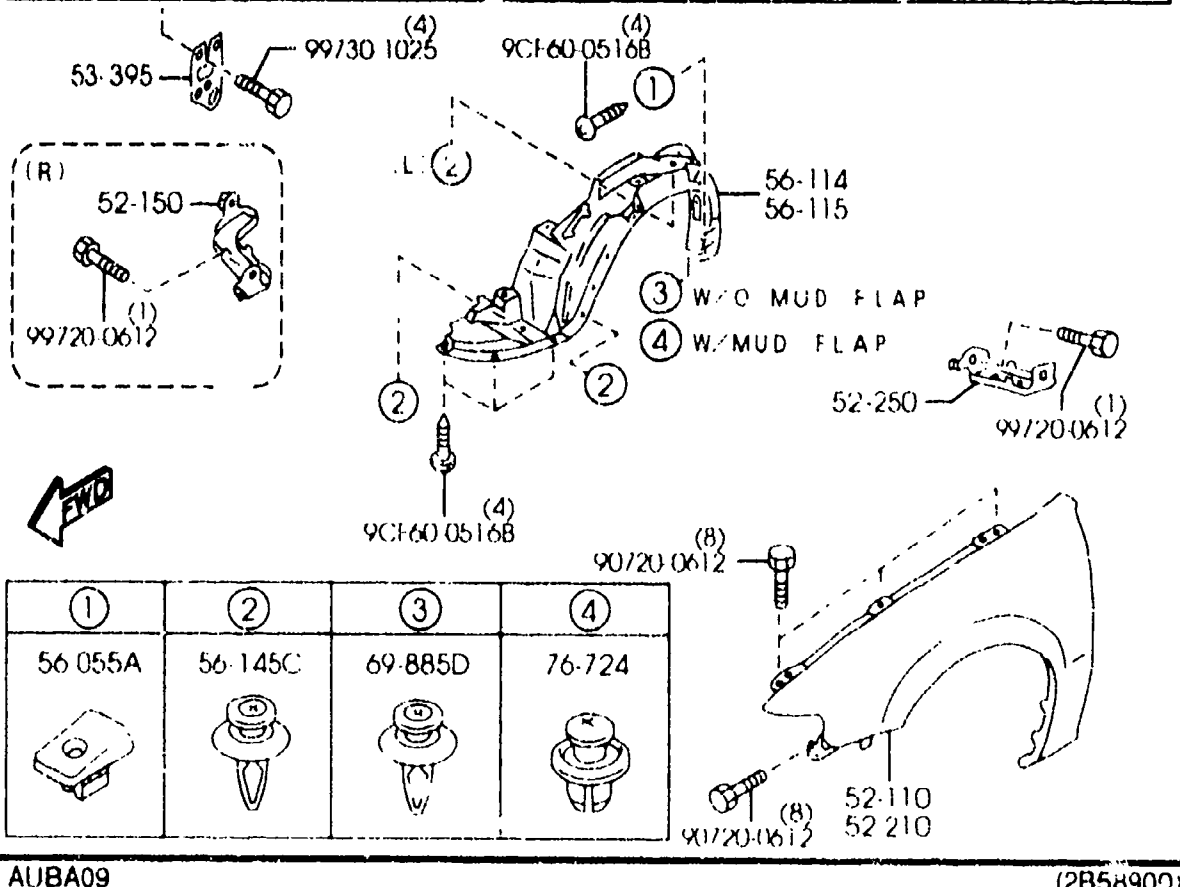
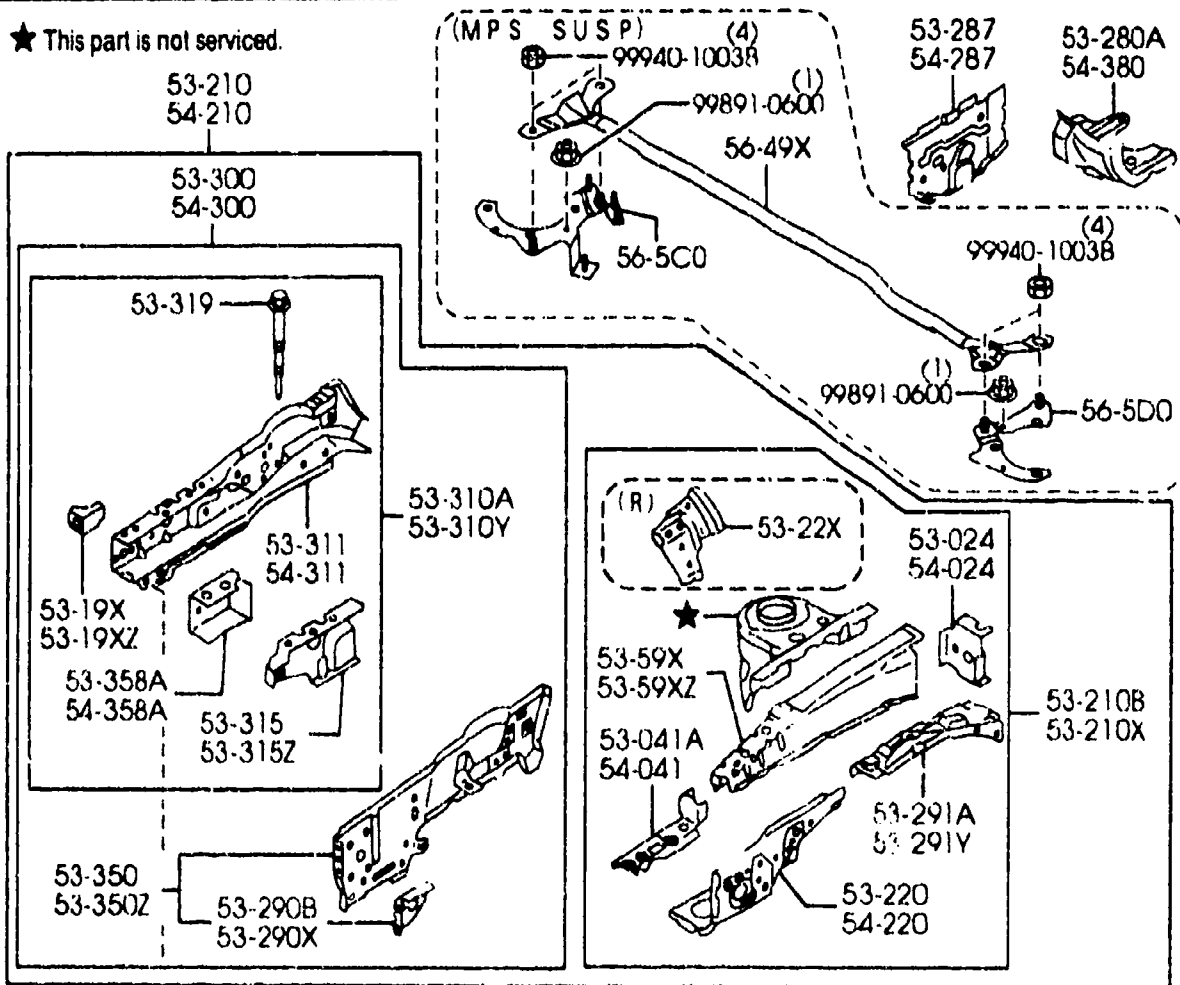

PART NO.	QTY	MODEL/RESTRICTION	MODEL/RESTRICTION	MODEL/RESTRICTION	FROM-TG
53-350 B25D-53-320A	1	FRAME(R),SIDE-OUTER	CADRE LATERAL EXT.(D)		
53-350Z B25D-54-320A	1	FRAME(L),SIDE-OUTER	CADRE LATERAL EXT.(G)		
53-358A B25D-53-351	1	REINFORCEMENT(R)	ARMATURE (D)		
53-395 B25D-53-361A	2	HOOK,TIE DOWN-FRT FR AME	CROCHET,P.FIXAT.-CHA SSIS		
53-59X BL2A-53-260	1	REINF.(R),WHEEL APRON	RENFORT(D),TABLIER		
53-59XZ BL2A-54-260	1	REINF.(L),WHEEL APRON	RENFORT(G),TABLIER		
54-024 B25D-54-263	1	GUSSET(L),WHEEL APRON	GOUSSET(G),TAB-LIER ROUES		
54-041 BJ0J-54-272A	1	REINF.(L),WHEEL APRON- UP.	RENFORT(G),TABLIER R QUE-S		
54-210 B2YD-54-20YD	1	PANEL(L),APRON & FRA ME	PASSAGE DE ROUE (G)		
54-220 BJ0J-54-220C	1	PANEL(L),WHEEL APRON -FRT	PANNEAU(AV G),TABLIER R		
54-287 B25D-54-281	1	REINF.(L),COWL SIDE PANEL	REINF.(G),CAPOT PANN .COTE		
54-300 B25D-54-31XD	1	FRAME(L),SIDE-FRONT	ARMATURE (G), COTE A V.		
54-311 B25D-54-311B	1	FRAME(L),INNER	CADRE(G),INT.		
54-358A B25D-54-351A	1	REINFORCEMENT(L)	ARMATURE (G)		

AUBA09

(2B58900)

CAT. AUBA09-02

2001-07



5320A FENDER & WHEEL APRON PANELS  
(4-DOOR)

5320A -4 \* FENDER & WHEEL APRON PANELS  
(4-DOOR)

★ This part is not serviced.

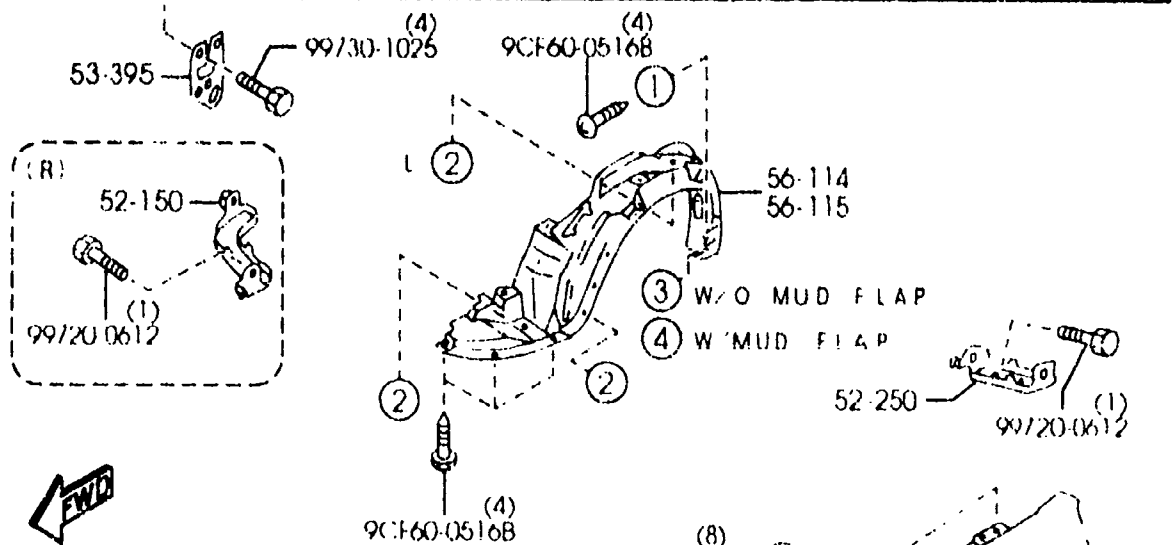
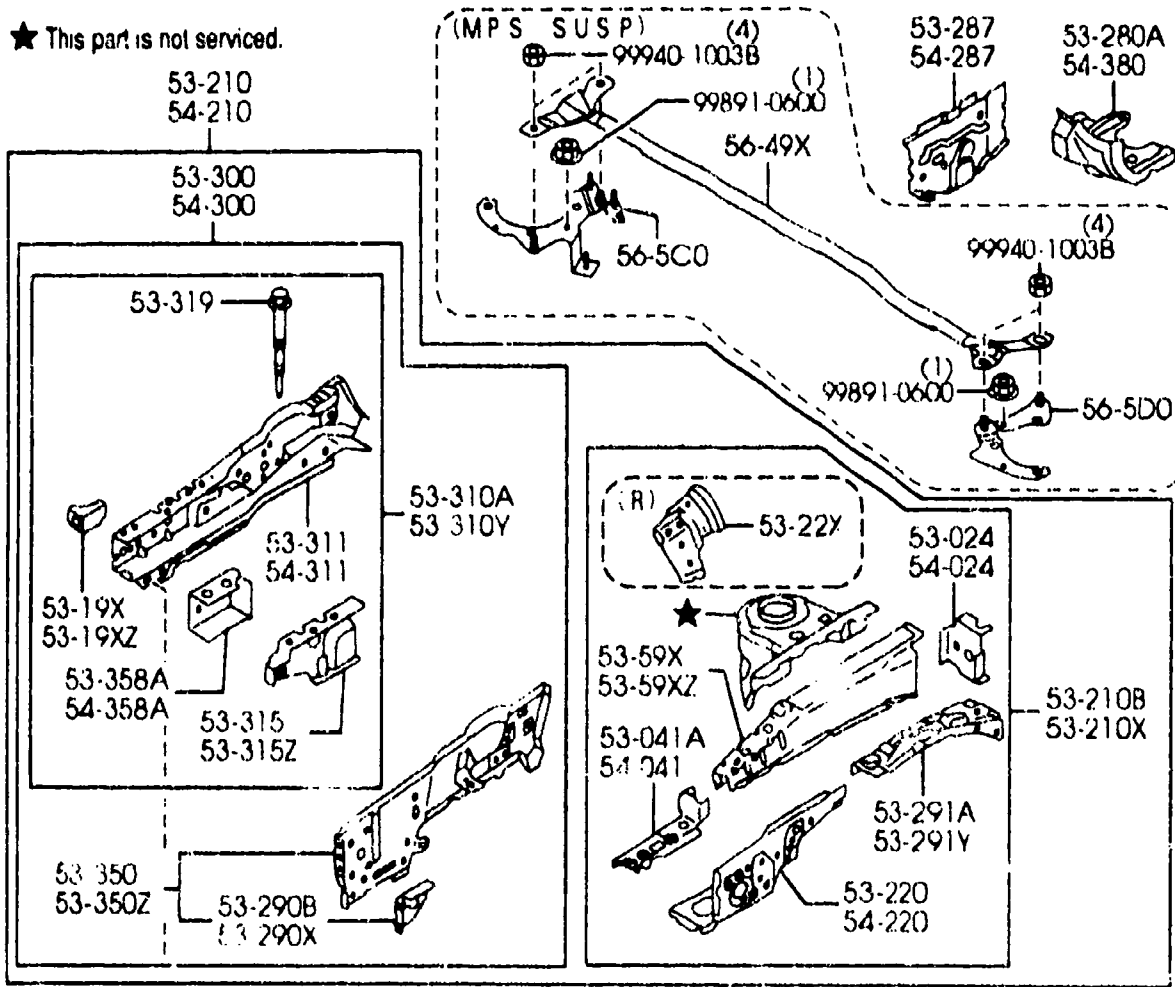

①	②	③	④
56-055A	56-145C	69-885D	76-724

AUBA09

(2B58900)

PART NO.	QTY	MODEL/RESTRICTION	MODEL/RESTRICTION	MODEL/RESTRICTION	FROM-TO
54-380		FRAME(L), FRONT-REAR	CADRE(G), AV-AR		
GA5R-54-390F	1				
56-055A		GROMMET	ANNEAU		
B25D-51-832	2				
56-114		GUARD(R), MUD	GARDE-BOUD(D)		
B30P-56-130A	1	(MPS SUSP)	(SUSP. MPS)		
B30D-56-131A	1	(SPORT SUSP)	(SUSP. SPORTIVE)		
56-115		GUARD(L), MUD	GARDE-BOUE(G)		
B30P-56-140A	1	(W/O MUD FLAP) (MPS SUSP)	(SUSP. MPS)		
B30D-56-141A	1	(SPORT SUSP)	(SUSP. SPORTIVE)		
56-145C		CLIP, MUD GUARD	ETRIER, GARDE BOUE		
BC1D-56-145	23				
56-49X		BAR, STRUT	BARE, RENFORT-TABLIER ROUE		
BN7H-56-49X	1	(W/STRUT BAR) (MPS SUSP)	(SUSP. MPS)		
*B28V-56-49XE	1	(W/STRUT BAR) (SPORT SUSP)	(SUSP. SPORTIVE)		1601-
56-500		STAY(R), SIDE STEP	ETAI(D), MARCHEPIED L ATRAL		
BN5V-56-50X	1	(W/STRUT BAR)			
56-500		STAY(L), SIDE STEP	ETAI(G), MARCHEPIED L ATRAL		
B28V-56-50X	1	(W/STRUT BAR)			
69-885D		FASTENER	AGRAFE		
NA01-56-145	4	(W/O MUD FLAP) (SPORT SUSP)	(SUSP. SPORTIVE)		
76-724		RIVET	RIVET		
B092-51-833	4	(W/MUD FLAP) (SPORT SUSP)	(SUSP. SPORTIVE)		
B092-51-833	4	(MPS SUSP)	(SUSP. MPS)		

1601 BJ22\* -480682

CAT. AUBA09-02

2001-07

5320AA FENDER & WHEEL APRON PANELS  
(5-DOOR)

5320AA-1 FENDER & WHEEL APRON PANELS  
(5-DOOR)

★ This part is not serviced.

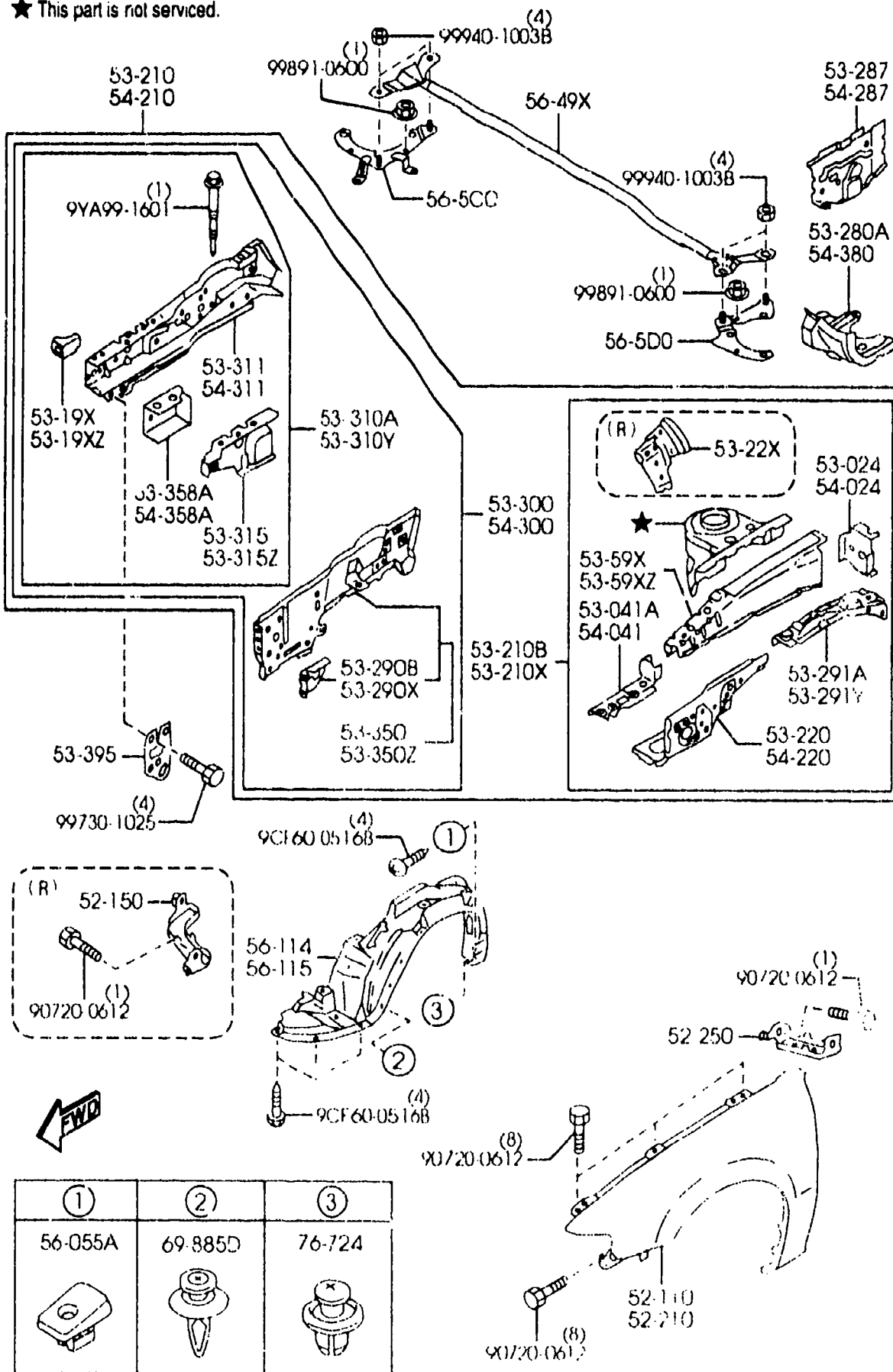

PART NO.	QTY	MODEL/RESTRICTION	MODEL/RESTRICTION	MODEL/RESTRICTION	FROM-TO
52-110		PANEL(R), FENDER-FRT.	AILE AVANT (D)		
BN5V-52-111	1				
52-150		STAY(R), FENDER	ETAI(D), AILE		
B25D-52-140A	1				
52-210		PANEL(L), FENDER-FRT.	AILE AVANT (G)		
BN5V-52-211	1				
52-250		STAY(L), FENDER	ETAI(G), AILE		
B25D-52-240A	1				
53-024		GUSSET(R), WHEEL APRON	GOUSSET(D), TABLIER R		
B25D-53-263	1		QUES		
53-041A		REINF.(R), WHEEL APRON-UP.	RENFORT(D), TABLIER R		
BJ0J-53-272A	1		QUE-S		
53-19X		BRKT(R), BUMPER-F. FR	SUPPORT(D), AMORT.-CH		
B25D-53-335A	1		AS.AV		
53-19XZ		BRKT(L), BUMPER-F. FR	SUPPORT(G), AMORT.-CH		
B25D-54-335A	1		AS.AV		
53-210		PANEL(R), APRON & FRAME	PASSAGE DE ROUE (D)		
B2YD-53-20YB	1				
53-210B		PANEL(R), WHEEL APRON	PANNEAU(D), TABLIER R		
B2YD-53-21YB	1		QUE		
53-210X		PANEL(L), WHEEL APRON	PANNEAU(G), TABLIER R		
B2YD-54-21YE	1		QUE		
53-22X		REINF-NO.3, ENG. MTG.	RENFORT NO.3 MONTAG		
BL2A-53-22X	1		MOTEU		
53-220		PANEL(R), WHEEL APRON-FRT	PANNEAU(AV.D), TABLIER		
BJ0J-53-220B	1		R		
53-280A		FRAME(R), FRONT-REAR	CADRE(D), AV-AR		
GA5R-53-390F	1				

AUBA09

(2B58790)

CAT. AUBA09-02

2001-07



5320AA FENDER & WHEEL APRON PANELS  
(5-DOOR)

★ This part is not serviced.

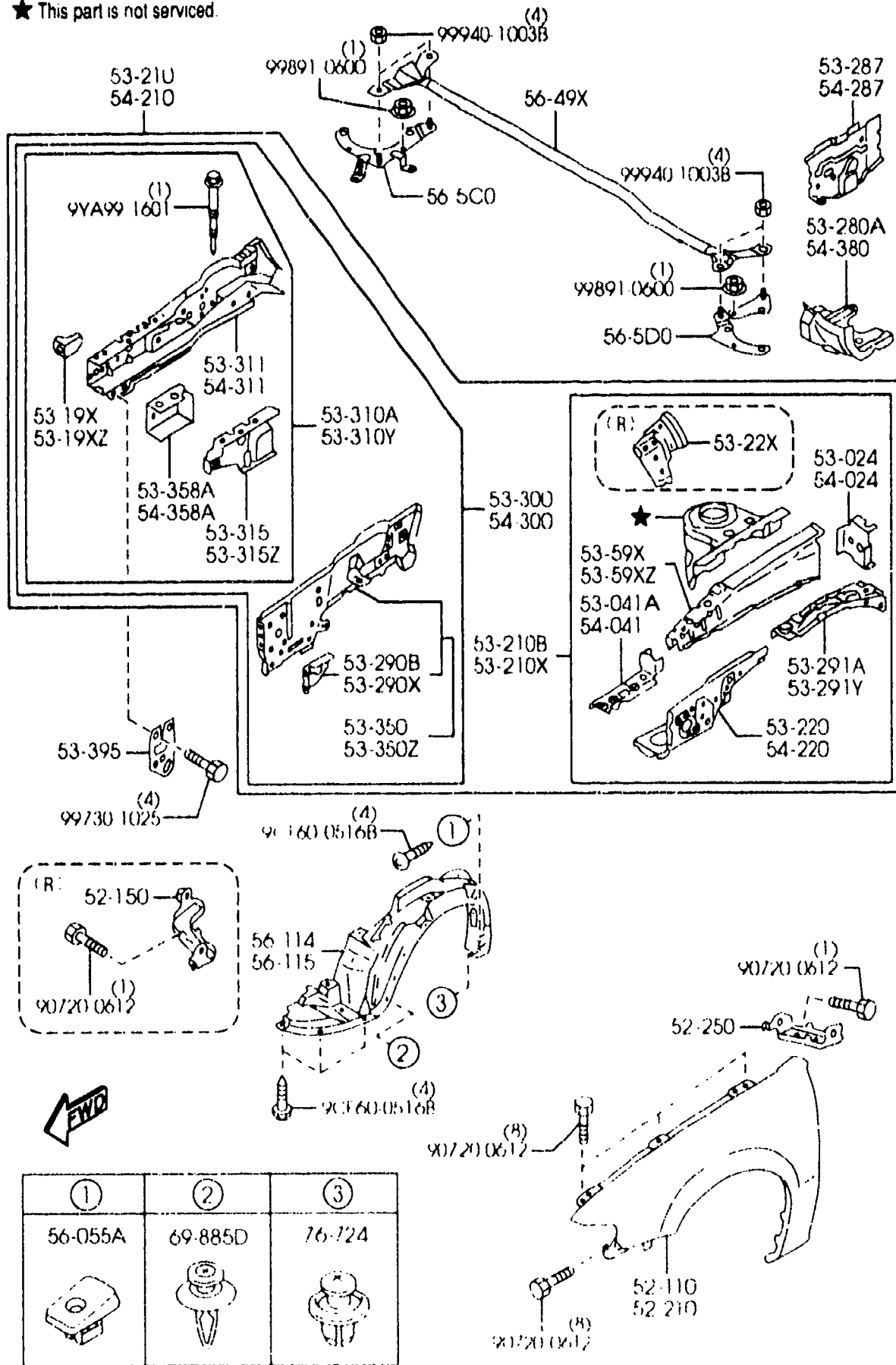

AUBA09

(2B58790)

5320AA-3 FENDER & WHEEL APRON PANELS  
(5-DOOR)

PART NO.	QTY	MODEL/RESTRICTION	MODEL/RESTRICTION	MODEL/RESTRICTION	FROM-TO
53-358A	1	REINFORCEMENT(R)	ARMATURE (D)		
B25D-53-351	1				
53-395	2	HOOK,TIE DOWN-FRT FR	CROCHET,P.FIXAT.-CHA		
B25D-53-361A	2		SSIS		
53-59X	1	REINF.(R),WHEEL APRO	RENFORT(D),TABLIER		
BL2A-53-260	1		N		
53-59XZ	1	REINF.(L),WHEEL APRO	RENFORT(G),TABLIER		
BL2A-54-260	1		N		
54-024	1	GUSSET(L),WHEEL APRO	GOUSSET(G),TAB-LIER		
B25D-54-263	1		ROUES		
54-041	1	REINF.(L),WHEEL APRO	RENFORT(G),TABLIER R		
BJ0J-54-272A	1		N-UP-S		
54-210	1	PANEL(L),APRON & FRA	PASSAGE DE ROUE (G)		
B2YD-54-20YD	1		ME		
54-220	1	PANEL(L),WHEEL APRON	PANNEAU(AV.G),TABLIE		
BJ0J-54-220C	1		-FRT		
54-287	1	REINF.(L),COWL SIDE	REINF.(G),CAPOT PANN		
B25D-54-281	1		PANEL		
54-300	1	FRAME(L),SIDE-FRONT	ARMATURE (G), COTE A		
B25H-54-31XC	1		V.		
54-311	1	FRAME(L),INNER	CADRE(G),INT.		
B25D-54-311B	1				
54-358A	1	REINFORCEMENT(L)	ARMATURE (G)		
B25D-54-351A	1				
54-380	1	FRAME(L),FRONT-REAR	CADRE(G),AV-AR		
GA5R-54-390F	1				
56-055A	2	GROMMET	ANNEAU		
B25D-51-832	2				

CAT. AUBA09-02

2001-07

5320AA FENDER & WHEEL APRON PANELS  
(5-DOOR)

5320AA-4 \* FENDER & WHEEL APRON PANELS  
(5-DOOR)

★ This part is not serviced.

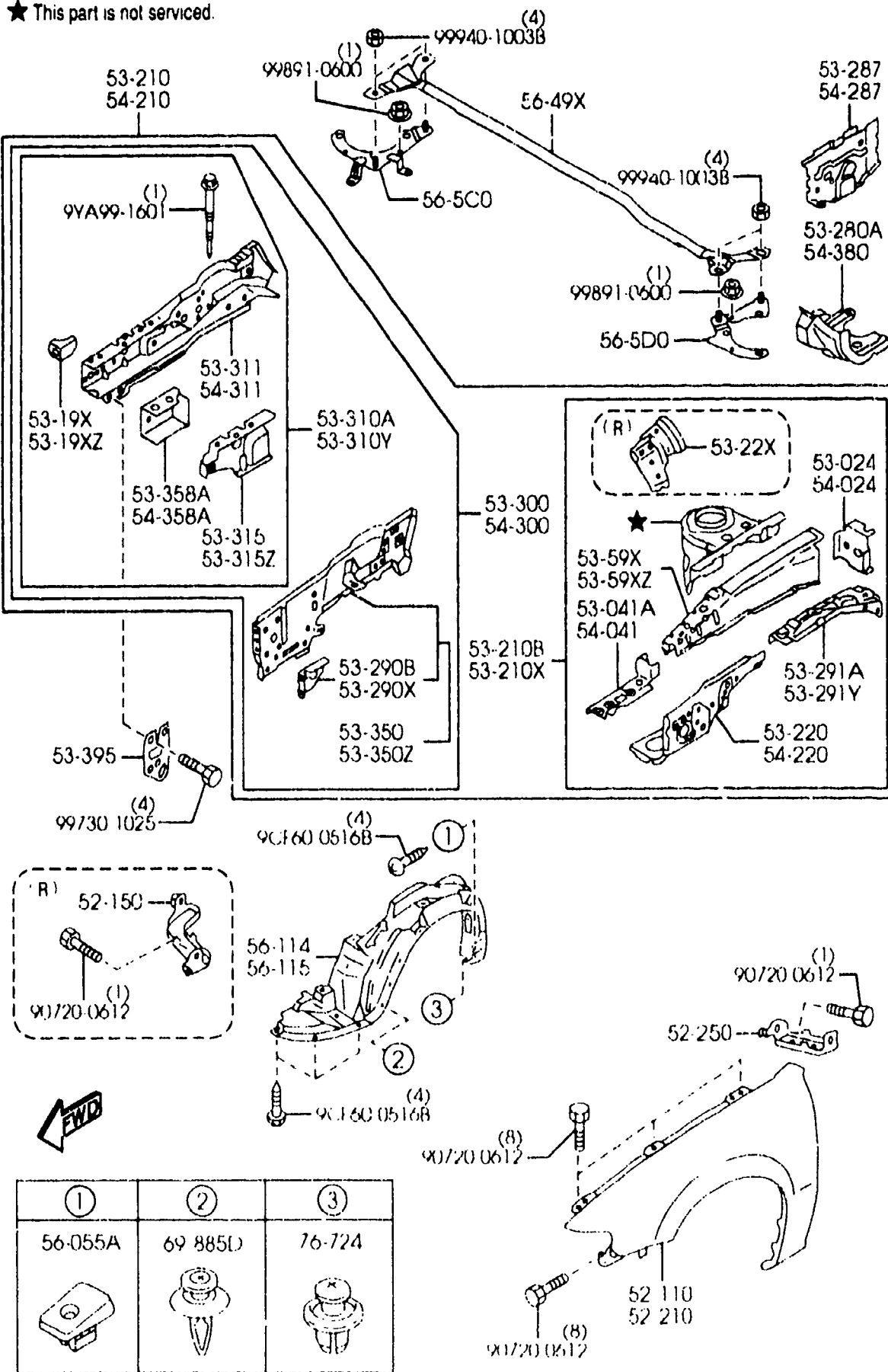

PART NO.	QTY	MODEL/RESTRICTION	MODEL/RESTRICTION	MODEL/RESTRICTION	FROM-TO
56-114		GUARD(R),MUD	GARDE-BOUD(D)		
B30P-56-130A	1				
56-115		GUARD(L),MUD	GARDE-BOUE(G)		
B30P-56-140A	1				
56-49X		BAR,STRUT	BARE,RENFORT-TABLIER ROUE		
B28V-56-49XE	1 (W/STRUT BAR)				
56-5C0		STAY(R),SIDE STEP	ETAI(D),MARCHEPIED L ATRAL		
BN5V-56-5CX	1 (W/STRUT BAR)				
56-5D0		STAY(L),SIDE STEP	ETAI(G),MARCHEPIED L ATRAL		
B28V-56-5DX	1 (W/STRUT BAR)				
69-885D		FASTENER	AGRAFE		
NA01-56-145	23				
76-724		RIVET	RIVET		
B092-51-833	4				

AUJBA09

(2B58790)

CAT. AUJBA09-02

2001-07

PART NO.	QTY	MODEL/RESTRICTION	MODEL/RESTRICTION	MODEL/RESTRICTION	FROM-TO
+-----+   53-400   +-----+ BJYJ-53-4A0B	1	PANEL, DASH-LOWER	TRAVERSE INFERIEURE		
+-----+   54-510   +-----+ BJQJ-53-500J A (BJQJ-53-500K)	1	PANEL, COWL & DASH	PANNEAU, CAPOTAGE & TABLIE		-1301
BJQJ-53-500K	1				1301-
1301 BJ22* -440775					

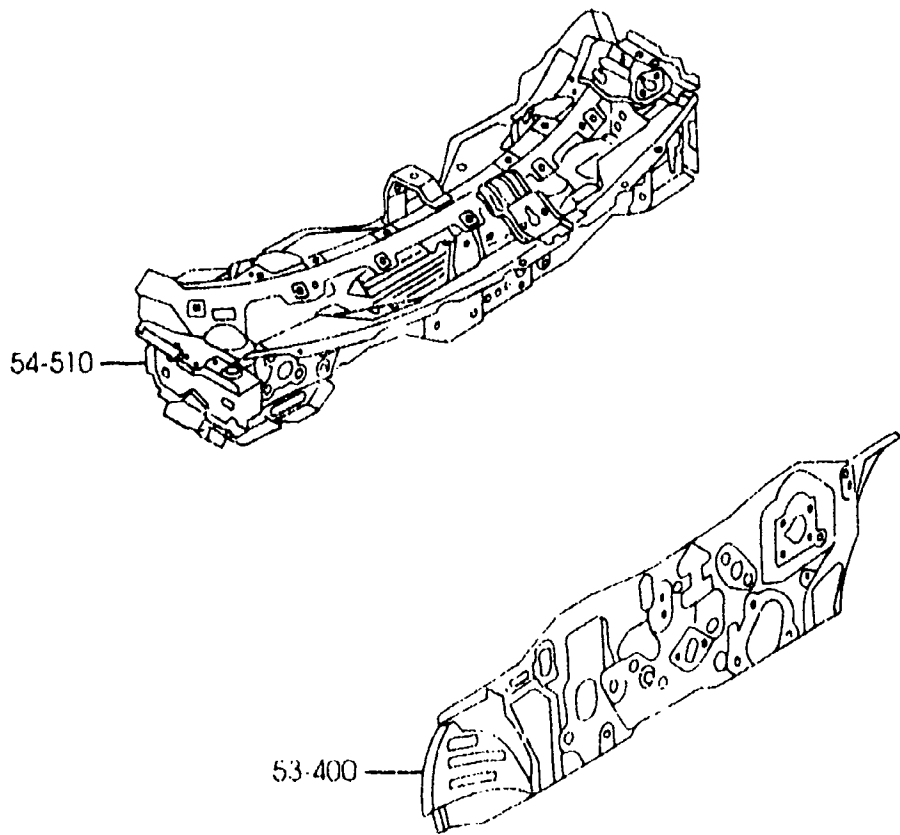

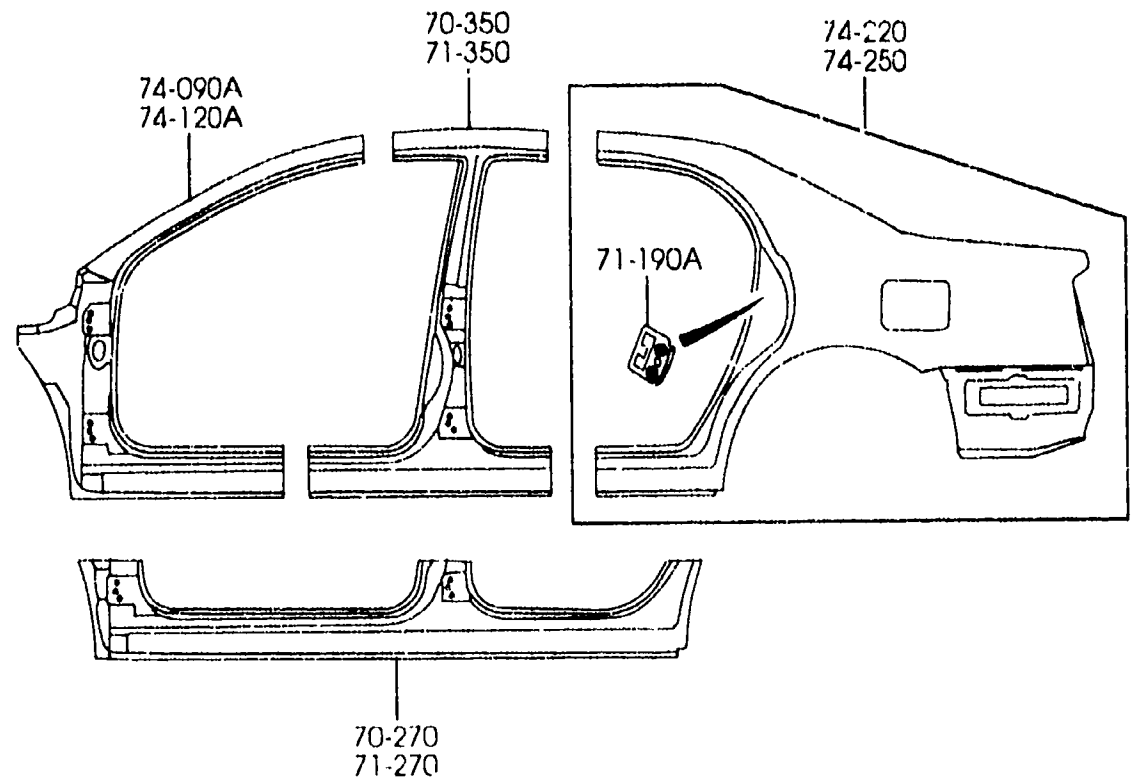
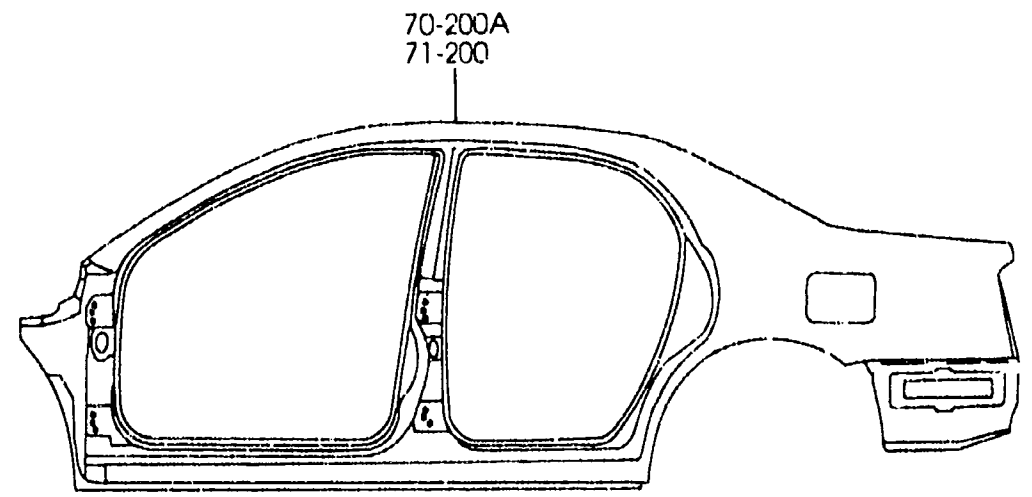
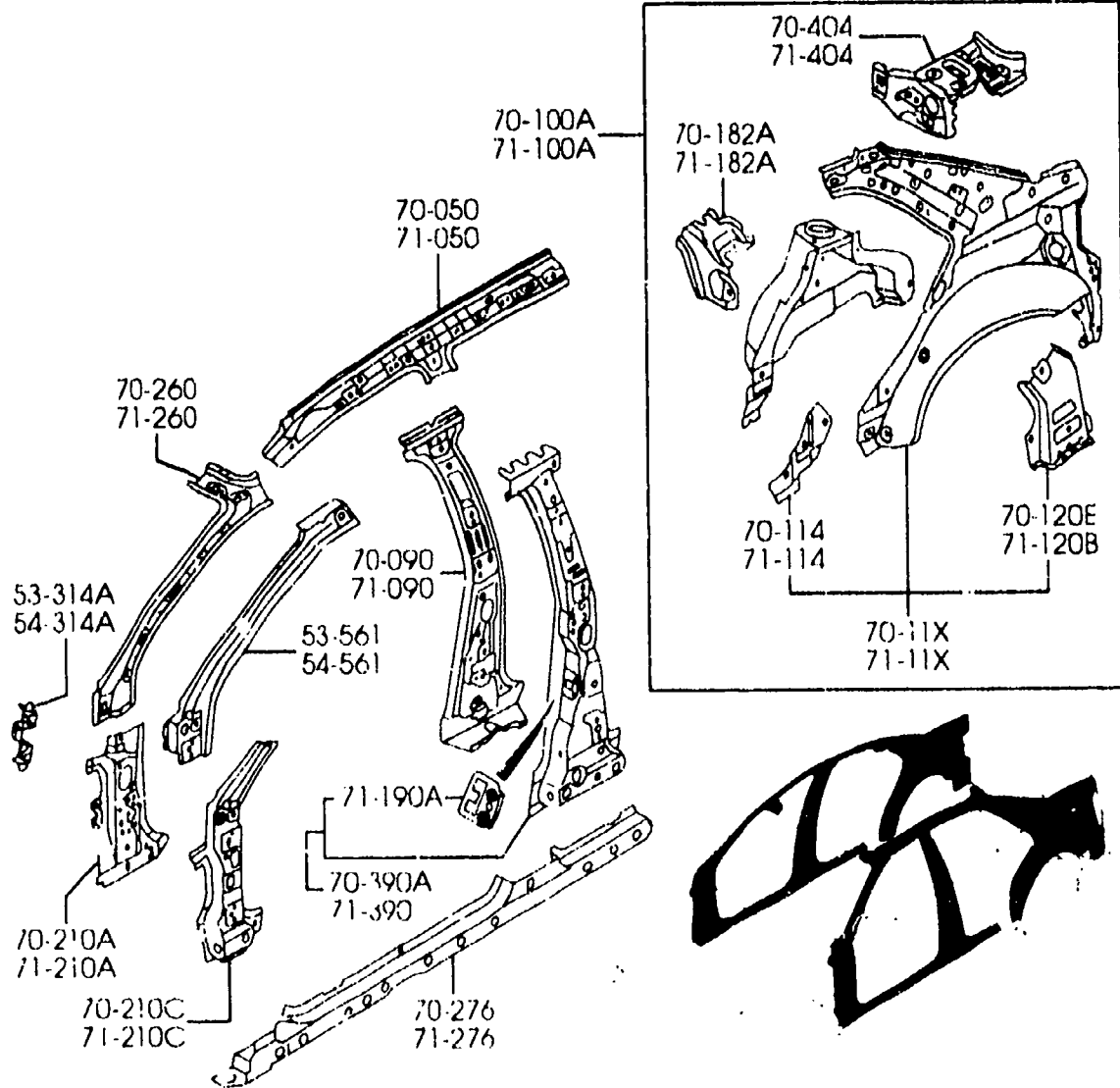
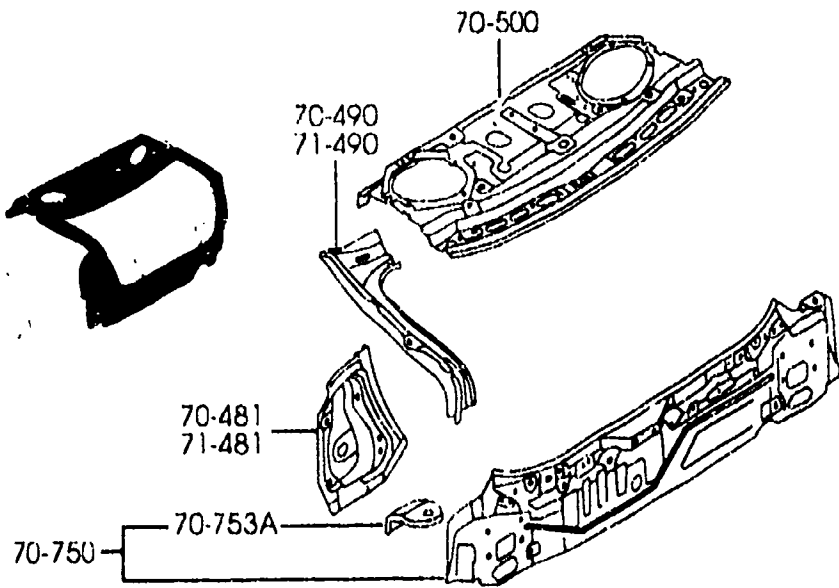

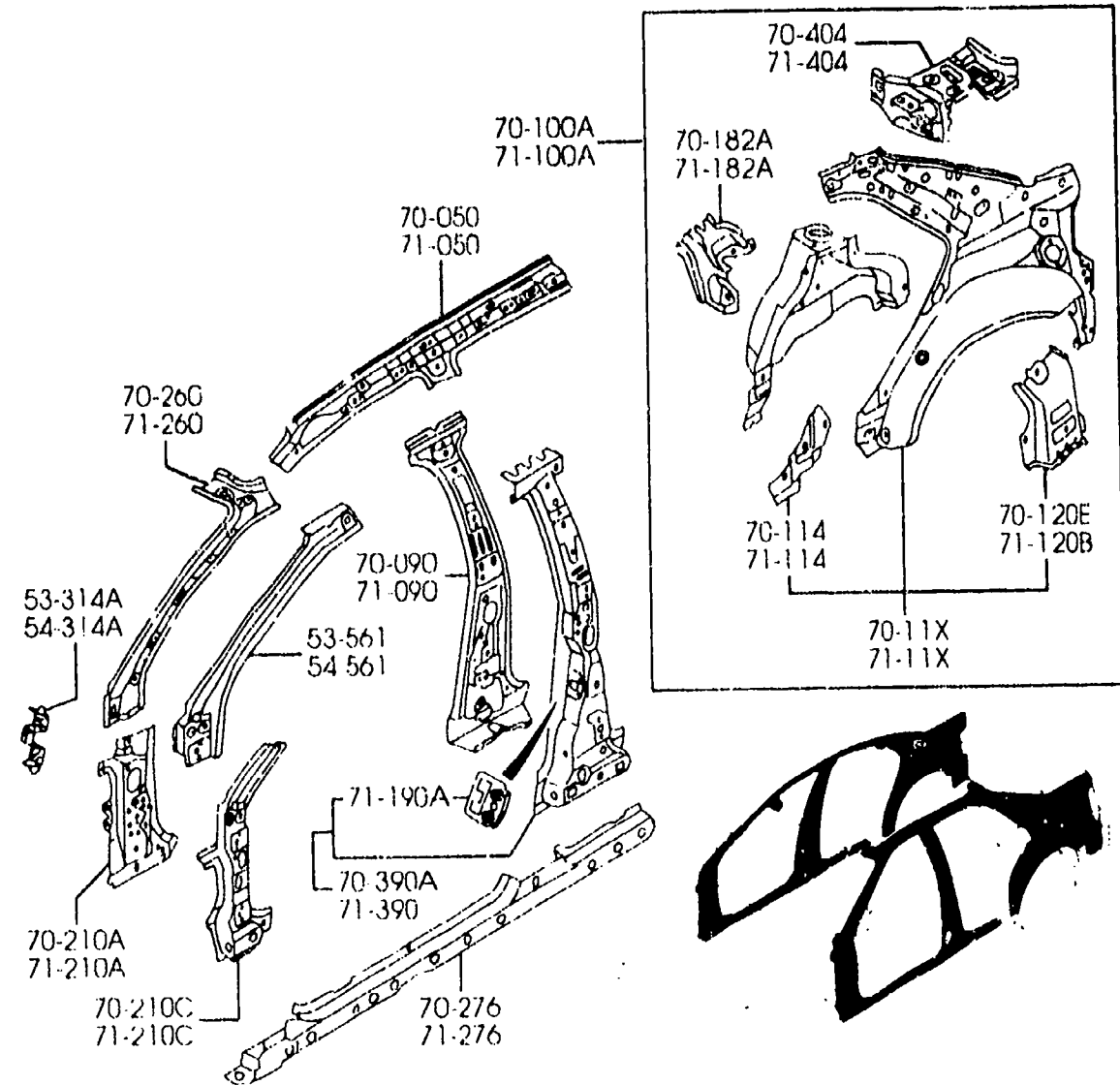
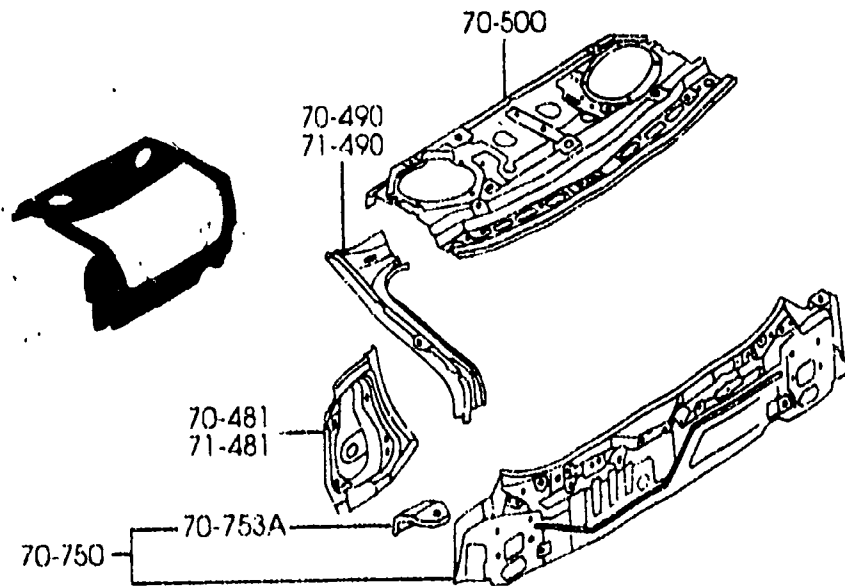

PART NO.	QTY	MODEL/RESTRICTION	MODEL/RESTRICTION	MODEL/RESTRICTION	FROM-TO
53-314A B25D-70-260C	1	BRACKET(R), INST.	SUPPORT INSTRUMENTS(D)		
53-561 B25D-70-242	1	REINF.(R), F. PILLAR INNER	RENFORCE.(R)MONTANT-AVANT		
54-314A B25D-71-260C	1	BRACKET(L), INST.	SUPPORT INSTRUMENTS(G)		
54-561 B25D-71-242	1	REINF.(L), F. PILLAR INNER	RENFORCE(G)MONTANT, AVANT		
70-050 B25D-70-050D	1	RAIL(R), ROOF-INNER	GOUTTIERE (D), INTERIEUR T		
70-090 BJ0J-70-080	1	PILLAR(R), C.-INNER	MONTANT (D), CENTRAL INTE		
70-100A BJ0J-70-100	1	PANEL(R), REAR PILLAR	PANNEAU(D), MONTANT AR		
70-11X BJ0J-70-11X	1	PILLAR(R), REAR-INNER	PILIER(D), AR.-INT		
70-114 B25D-70-112	1	PLATE(R), END	FLASQUE ARR (D)		
70-120E B25D-70-120	1	REINF.(R), REAR PILLAR IN.	RENFORT(D), PILIER AR		
70-182A B25D-70-182A	1	GUSSET(R), PACKAGE	GOUSSET(D), EMBALLAGE		
70-200A BJYJ-70-20X	1	FRAME(R), SIDE-OUTER	CADRE LATERAL EXT.(D)		
70-210A B25D-70-230	1	PILLAR(R), HINGE	MONTANT (D), CHARNIERE		
70-210C BJ0J-70-030	1	REINF.(R), HINGE	RENFORT(D)CHARNIERE		



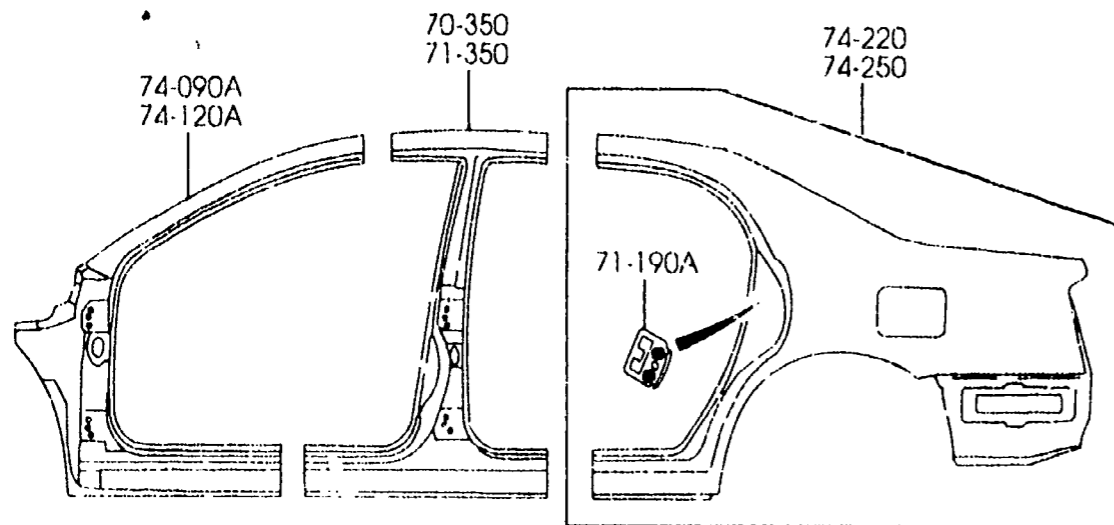
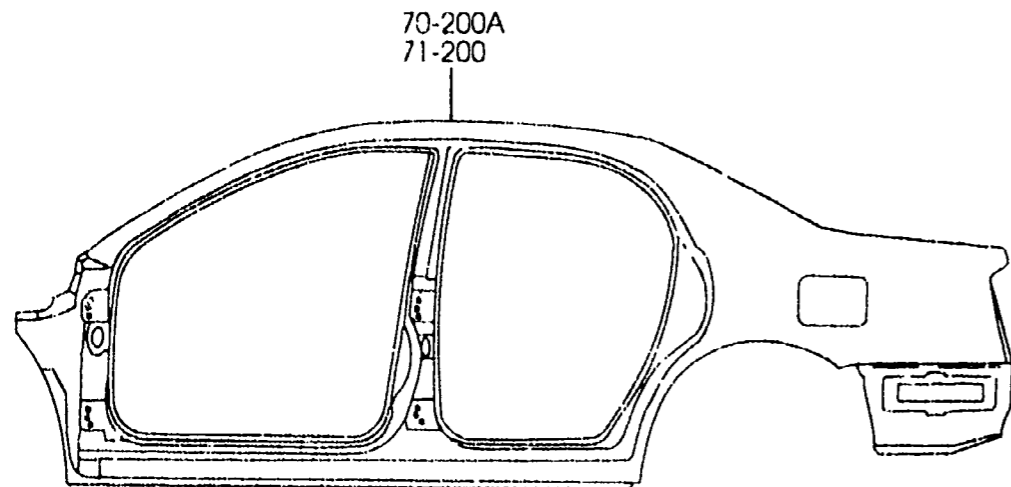

PART NO.	QTY	MODEL/RESTRICTION	MODEL/RESTRICTION	MODEL/RESTRICTION	FROM-TO
70-260 B25D-70-240	1	PILLAR(R),FRT.-INNER	MONTANT (D), AVANT I NTERI		
70-270 B2YD-70-270	1	PANEL(R),SIDE SILL	LONGERON EXT. (D)		
70-276 BJOJ-70-130B	1	REINF.(R),SIDE SILL	RENFORT		
70-350 B2YD-70-351	1	PILLAR(R),C.-OUTER	MONTANT (D), CENTRAL EXTE		
70-390A B25D-70-362C	1	REINF.(R),'B' PILLAR	RENFORT(D),'B' PILIE R		
70-404 B25D-70-180A	1	JUNCTION(R),PACKAGE	JONCTION(D)		
70-481 B25D-70-480	1	PLATE(R),CORNER	PLAQUE DE COIN(D)		
70-490 B25D-70-441	1	RAIL(R),RAIN-REAR	GOUTTIERE ARR.(D)		
70-500 B25D-70-500D	1	TRAY,PACKAGE	VIDE-POCHE		
70-750 BJOJ-70-750A	1	PANEL,REAR END	JUPE ARRIERE		
70-753A B25D-70-753	2	BRKT,BUMPER-REAR END	CONSOLE,P.-CHOCS,BOU T AR.		
71-050 B25D-71-050D	1	RAIL(L),ROOF-INNER	GOUTTIERE (G),INTERI EUR T		
71-090 BJOJ-71-080	1	PILLAR(L),CTR.-INNER	MONTANT C. (G), INTER IEUR		
71-100A BJOJ-71-160	1	PANEL(L),REAR PILLAR	PANNEAU(G),MONTANT A R		

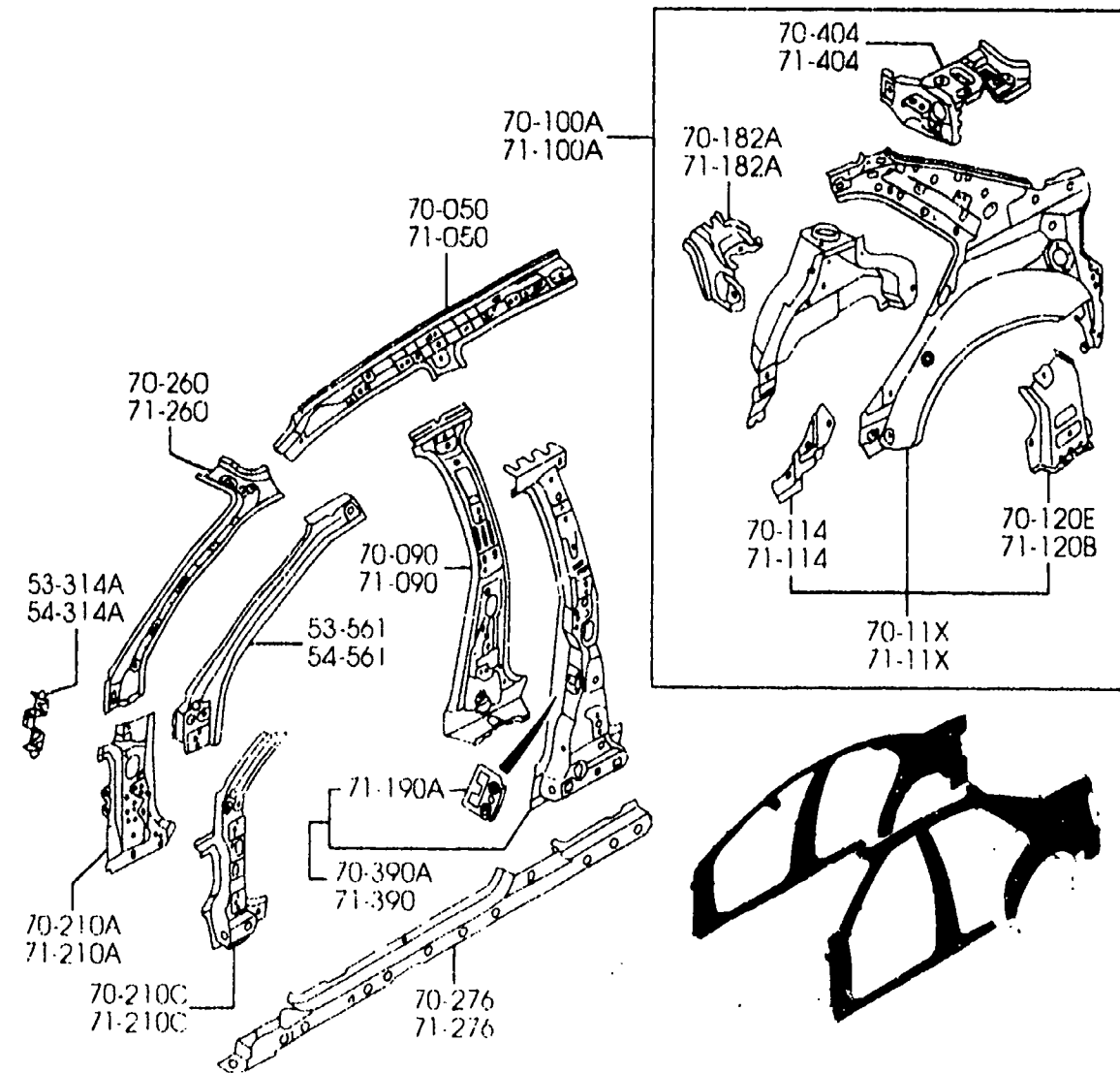
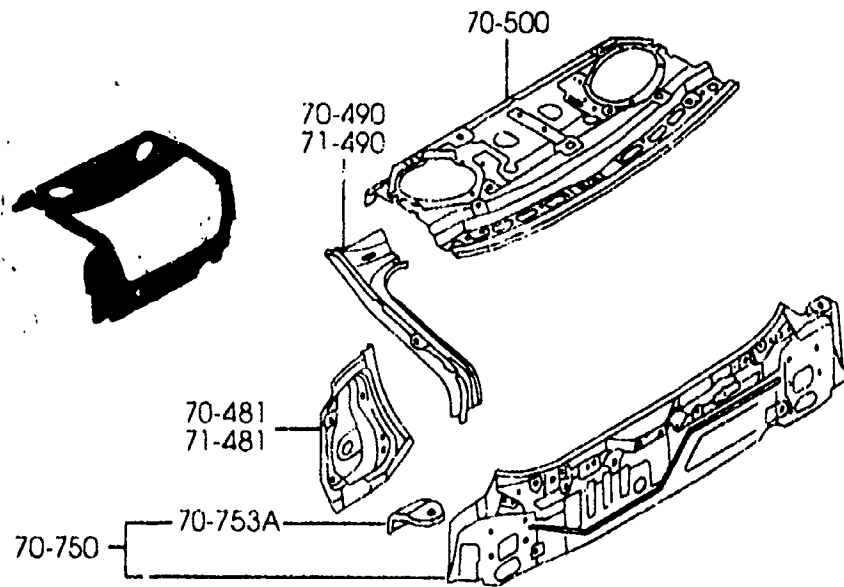

PART NO.	QTY	MODEL/RESTRICTION	MODEL/RESTRICTION	MODEL/RESTRICTION	FROM-TO
71-11X		PILLAR(L),REAR INNER	PILIER(G),INT AR.-AR		
BJ0J-71-11X	1				
71-114		PLATE(L),END	FLASQUE (G)		
B25D-71-112	1				
71-120B		REINF.(L).SUSPENSION	RENFORT(G),LOGEM SUS		
B25D-71-120	1	HSG	PENS		
71-182A		GUSSET(L),PACKAGE	GOUSSET(G),EMBALLAGE		
B25D-71-182A	1				
71-190A		PLATE,NUT	PLAQUE,ECROU		
GE4T-70-46X	4				
71-200		FRAME(L),SIDE-OUTER	CADRE LATERALSUP.(G)		
BJVJ-71-200	1				
71-210A		PILLAR(L),HINGE	MONTANT DE CHARNIERE		
B25D-71-230	1				
71-210C		REINF.(L),HINGE	RENFORT CHARNIERE(G)		
BJ0J-71-030	1				
71-260		PILLAR(L),FRT.-INNER	MONTANT INTERIEUR (G)		
B25D-71-240	1		), AV		
71-270		PANEL(L),SIDE SILL	PANNEAU(G),SEUIL LAT		
B2YD-71-270	1		ERAL		
71-276		REINF.(L),SIDE SILL	RENFORT		
BJ0J-71-130B	1				
71-350		PILLAR(L),CTR.-OUTER	MONTANT CENTRAL (G),		
B2YD-71-351	1		EXTE		
71-390		REINF.(L),'B' PILLAR	RENFORT(G),PILIER'R		
B25D-71-362C	1				
71-404		JUNCTION(L),PACKAGE	JONCTION(G)		
B25D-71-180A	1				

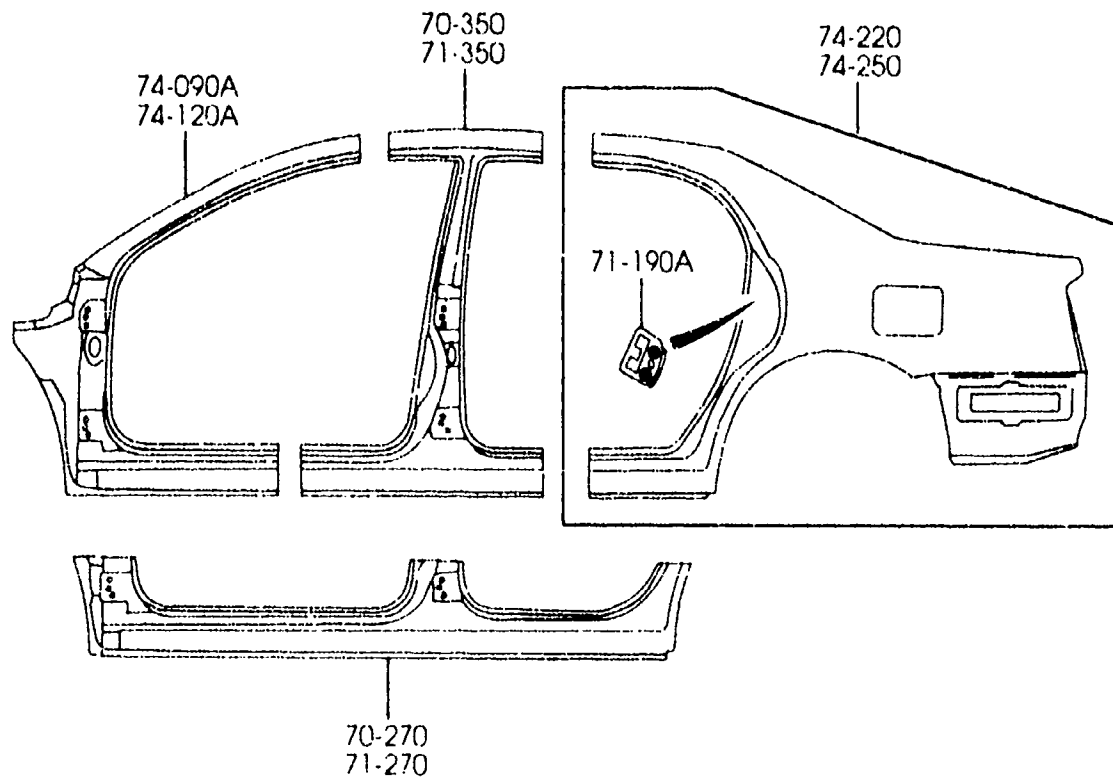
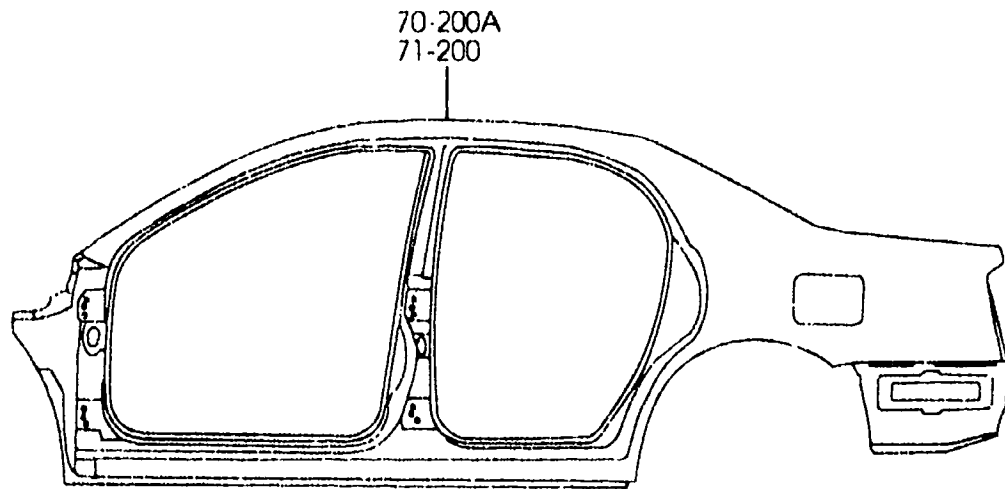

PART NO.	QTY	MODEL/RESTRICTION	MODEL/RESTRICTION	MODEL/RESTRICTION	FROM-TO
71-481 B25D-71-480	1	PLATE(L),CORNER	PLAQUE COIN(G)		
71-490 B25D-71-441	1	RAIL(L),RAIN-REAR	GOUTTIERE ARR.(G)		
74-090A BJYJ-70-221	1	PILLAR(R),FRONT-OUT.	MONTANT EXT,AV(D)		
74-120A BJYJ-71-220	1	PILLAR(L),FRONT-OUT.	MONTANT EXT.AV(G)		
74-220 B2YD-70-410	1	PANEL(R),FENDER-REAR	PANNEAU(D),PARE-CHOC S ARR		
74-250 B2YD-71-410	1	PANEL(L),FENDER-REAR	PANNEAU(G),PARE-CHOC S ARR		

★ This part is not serviced.

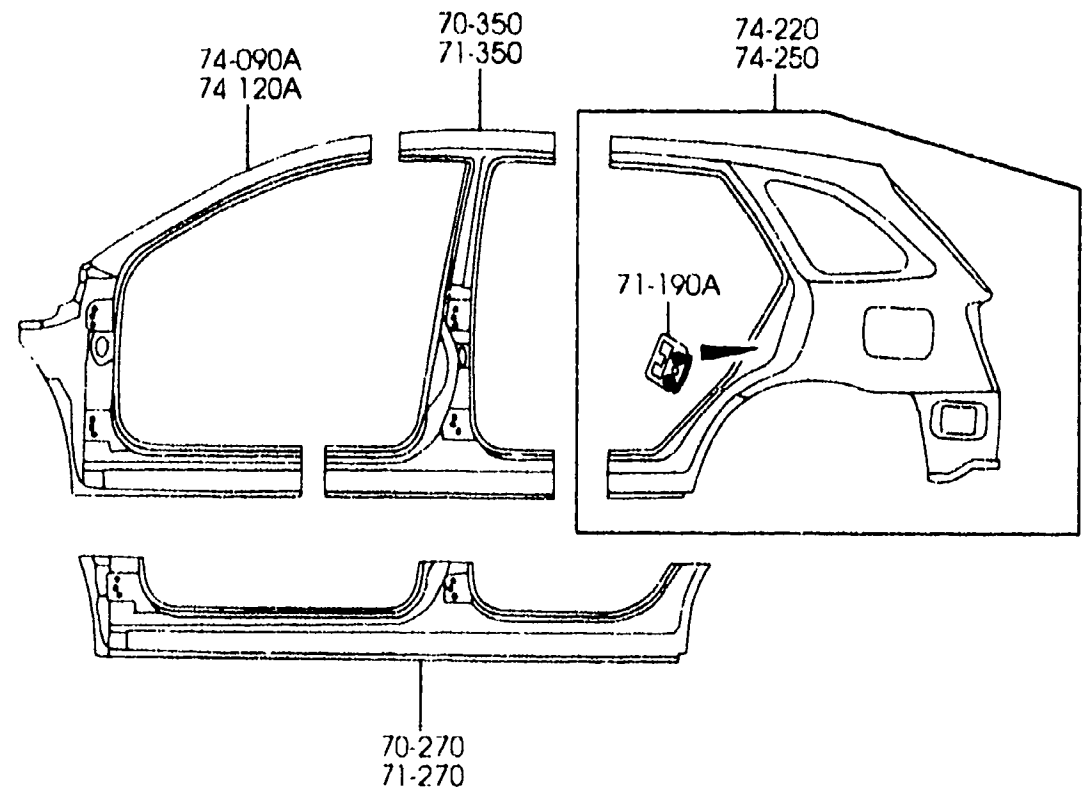
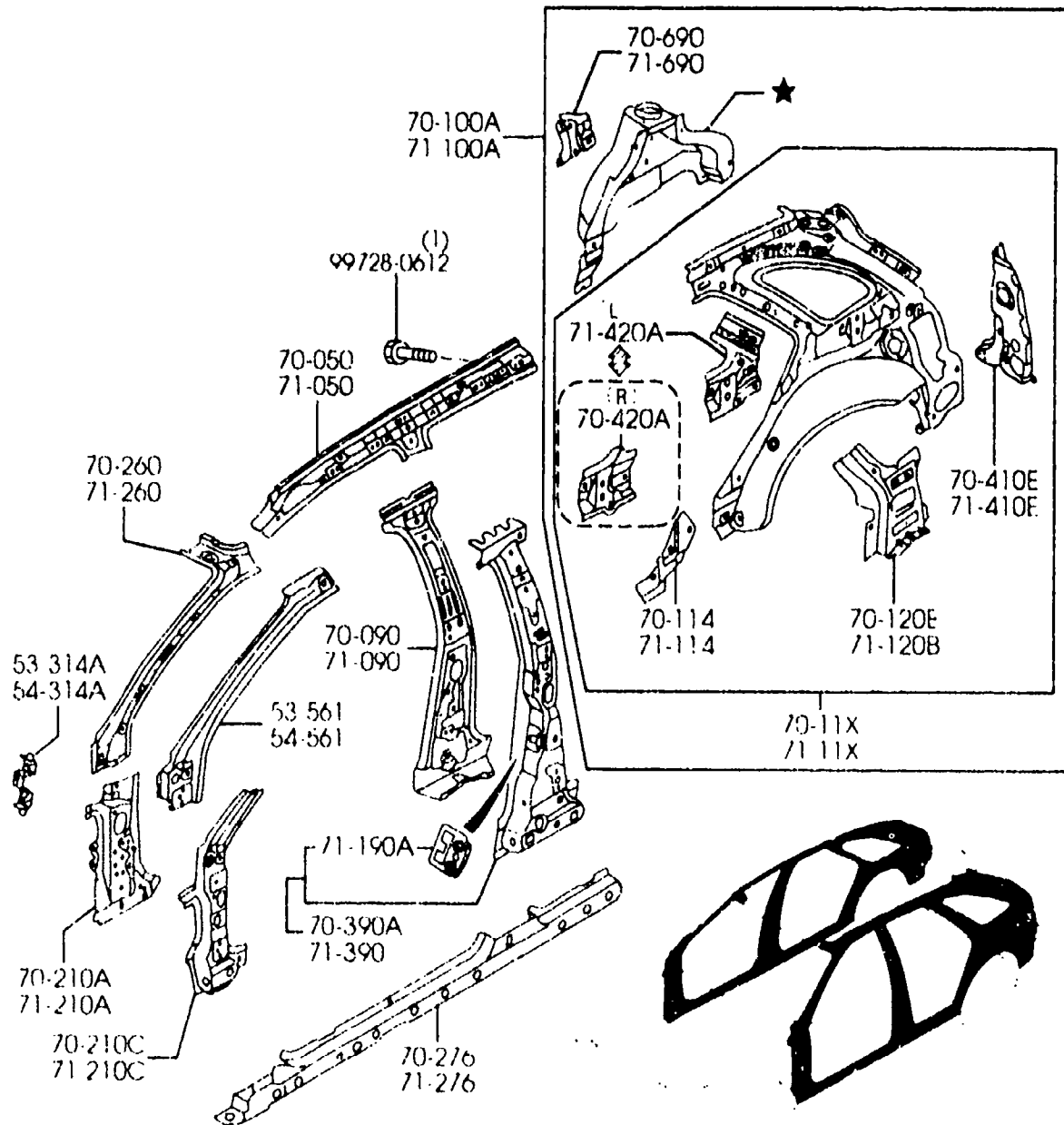
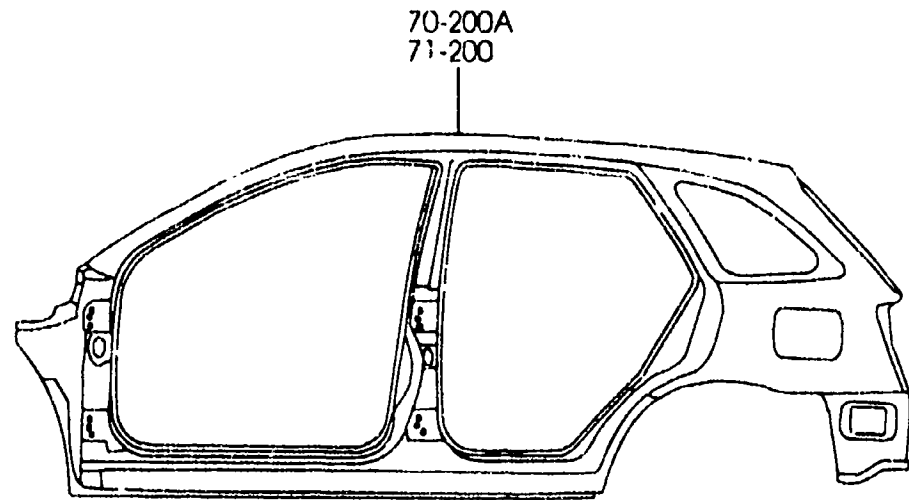
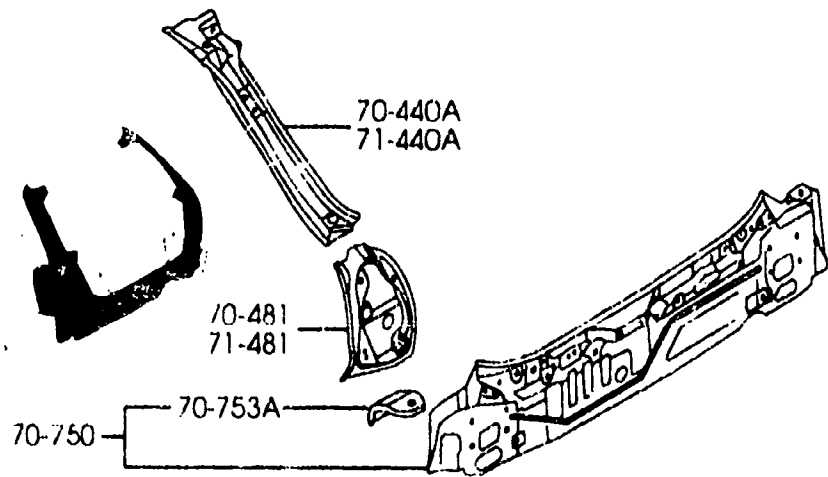

★ This part is not serviced

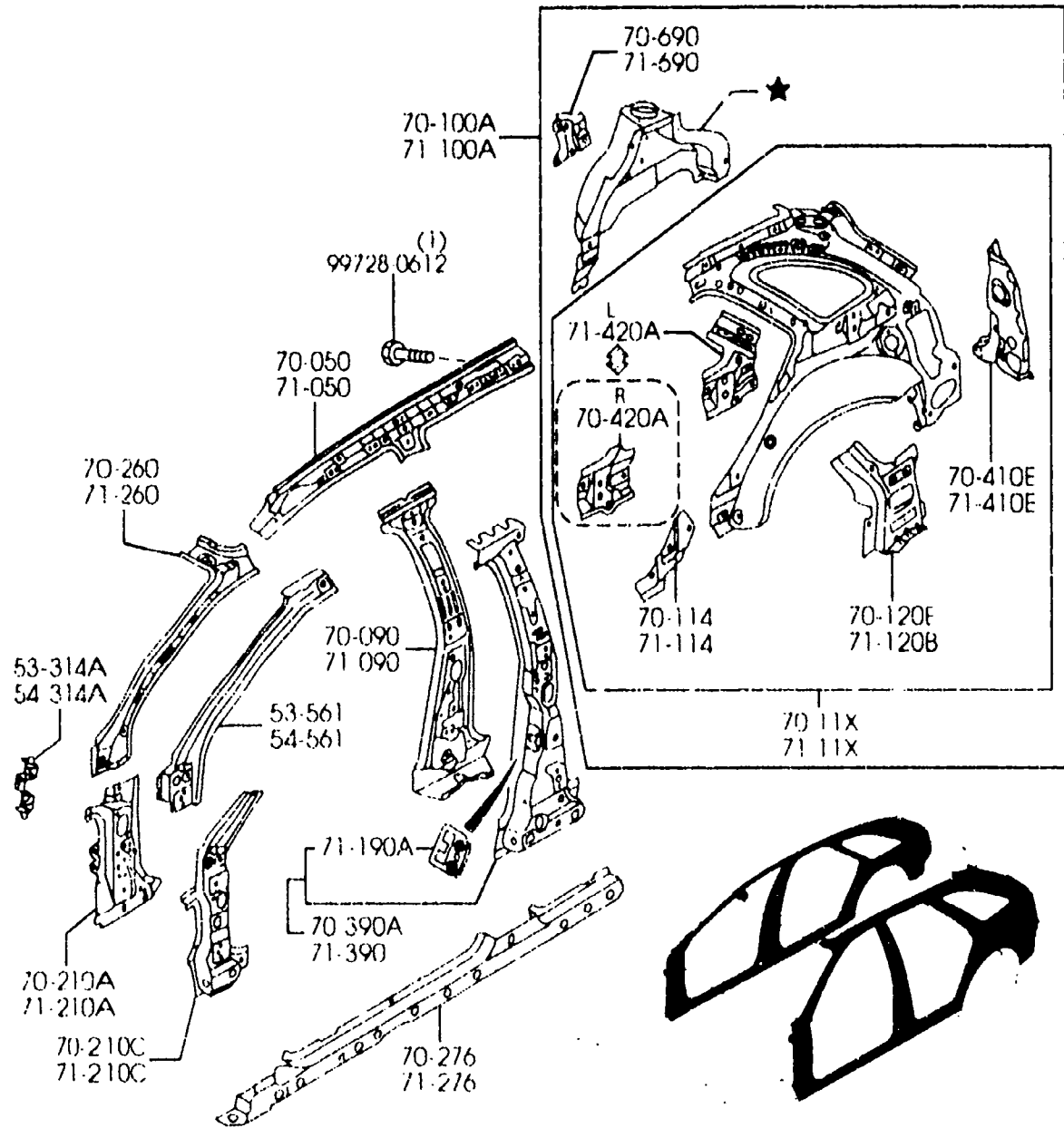
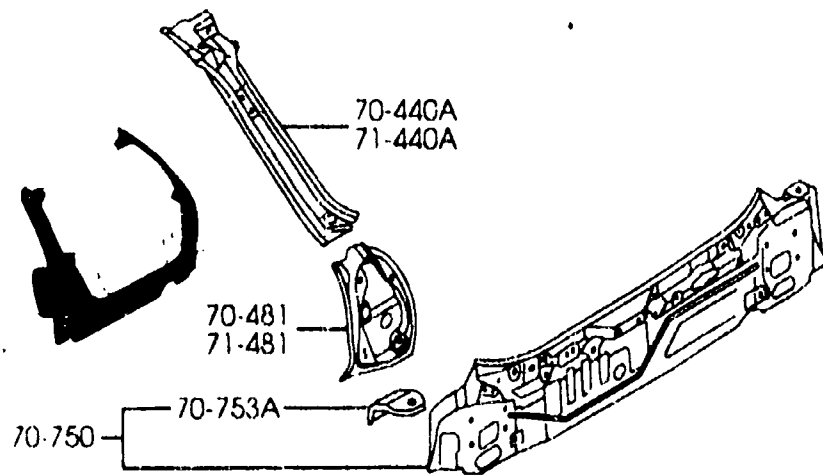

PART NO.	QTY	MODEL/RESTRICTION	MODEL/RESTRICTION	MODEL/RESTRICTION	FROM-TO
53-314A B25D-70-260C	1	BRACKET(R),INST.	SUPPORT INSTRUMENTS(D)		
53-561 B25D-70-242	1	REINF.(R),F. PILLAR INNER	RENFORCE.(R)MONTANT-AVANT		
54-314A B25D-71-260C	1	BRACKET(L),INST.	SUPPORT INSTRUMENTS(G)		
54-561 B25D-71-242	1	REINF.(L),F. PILLAR INNER	RENFORCE(G)MONTANT,AVANT		
70-050 B25R-70-050C	1	RAIL(R),ROOF-INNER	GOUTTIERE (D),INTERIEUR T		
70-090 BJ0J-70-080	1	PILLAR(R),C.-INNER	MONTANT (D), CENTRAL INTE		
70-100A BL2L-70-100	1	PANEL(R),REAR PILLAR	PANNEAU(D),MONTANT AR		
70-11X BJ3K-70-11XA	1	PILLAR(R),REAR-INNER	PILIER(D),AR.-INT		
70-114 B25D-70-112	1	PLATE(R),END	FLASQUE ARR (D)		
70-120E B25R-70-120	1	REINF.(R),REAR PILLAR IN.	RENFORT(D),PILIER AR		
70-200A B2YR-70-20X	1	FRAME(R),SIDE-OUTER	CADRE LATERAL EXT.(D)		
70-210A B25D-70-230	1	PILLAR(R),HINGE	MONTANT (D), CHARNIERE		
70-210C BJ0J-70-030	1	REINF.(R),HINGE	RENFORT(D)CHARNIERE		
70-260 B25D-70-240	1	PILLAR(R),FRT.-INNER	MONTANT (D), AVANT INTERI		

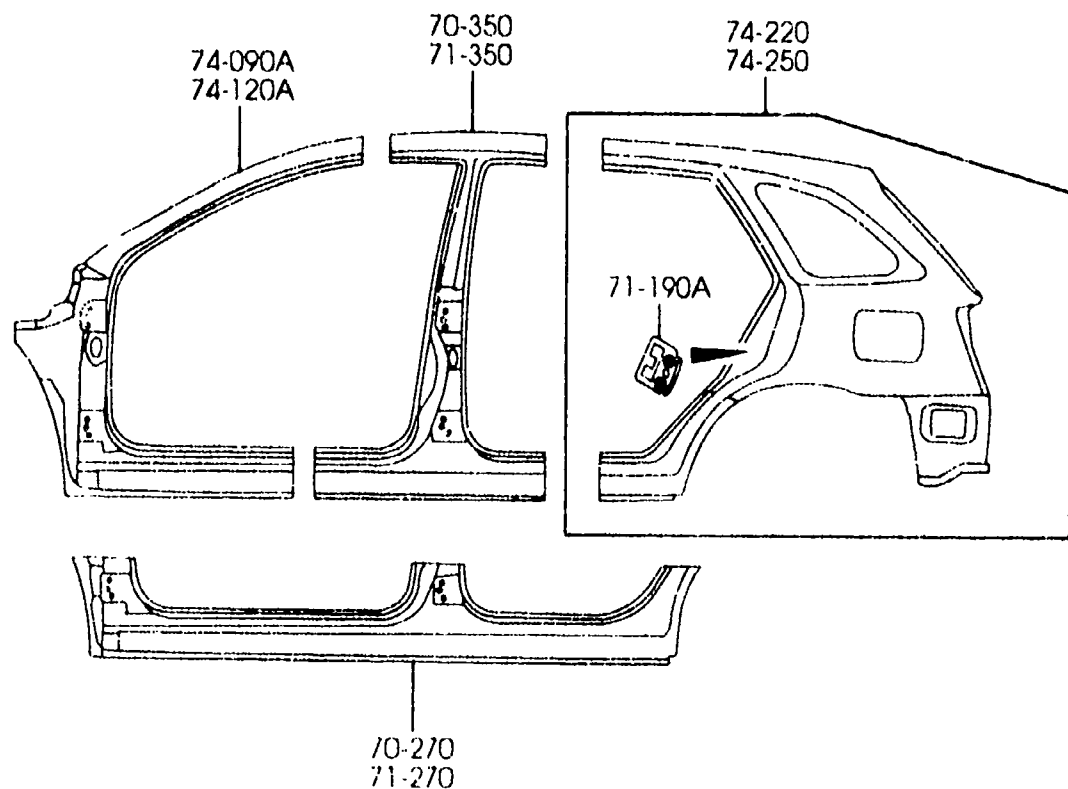
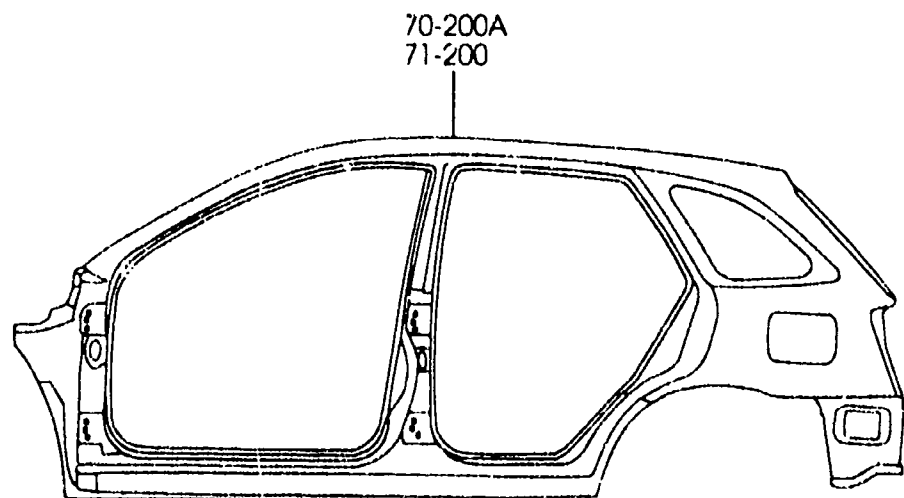

PART NO.	QTY	MODEL/RESTRICTION	MODEL/RESTRICTION	MODEL/RESTRICTION	FROM-TO
70-270 B2YR-70-270	1	PANEL(R),SIDE SILL	LONGERON EXT. (D)		
70-276 BJ0J-70-130B	1	REINF.(R),SIDE SILL	RENFORT		
70-350 B2YR-70-351	1	PILLAR(R),C.-OUTER	MONTANT (D), CENTRAL EXTE		
70-390A B30P-70-36Z	1	REINF.(R),'B' PILLAR	RENFORT(D),'B' PILIE R		
70-410E B25R-70-113A	1	PANEL(R),REAR SIDE	PANNEAU LATERAL AR(D )		
70-420A B25R-70-180A	1	BRKT(R),ANCHOR-SEAT BELT	SUPPORT(D),ANCRE-CEI NTURE		
70-440A B25R-70-44X	1	PILLAR'D'(R),OUT.-FE NDER	PILIER'D'(D),EXT.-P. CHOCS		
70-481 B25R-70-481	1	PLATE(R),CORNER	PLAQUE DE COIN(D)		
70-690 GE4T-70-16Y	1	GUSSET(R),WHEEL HOUS E	GOUSSET(D),LOGGE. RO UE		
70-750 BJ3K-70-750F A (BJ3K-70-750G) *BJ3K-70-750G	1	PANEL,REAR END	JUPE ARRIERE		-1801
70-753A B25D-70-753	2	BRKT,BUMPER-REAR END	CONSOLE,P.-CHOCS,BOU T AR.		1801-
71-050 B25R-71-050C	1	RAIL(L),ROOF-INNER	GOUTTIERE (G),INTERI EUR T		
71-090 BJ0J-71-080	1	PILLAR(L),CTR.-INNER	MONTANT C (G), INTER IEUR		

★ This part is not serviced.

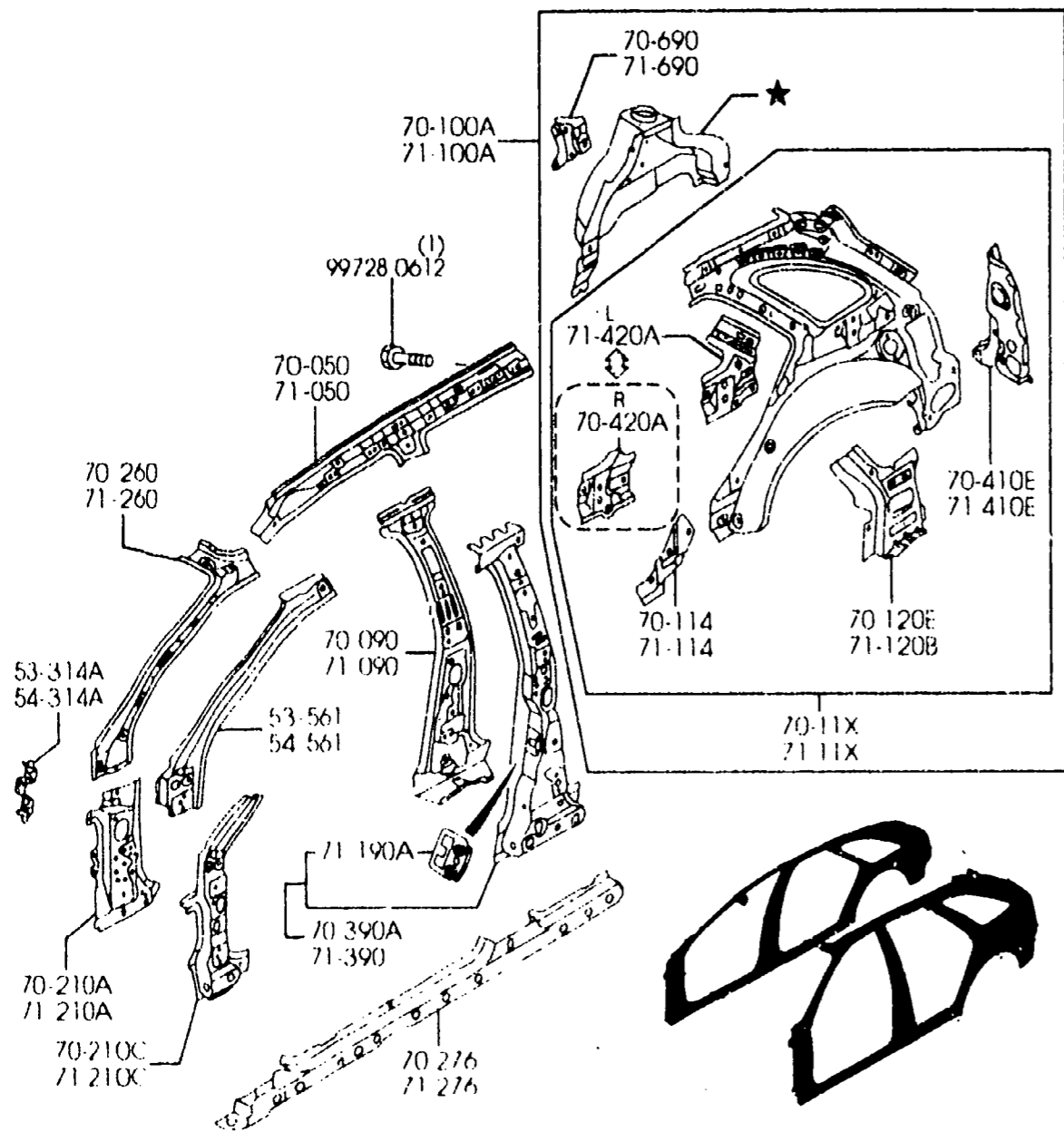
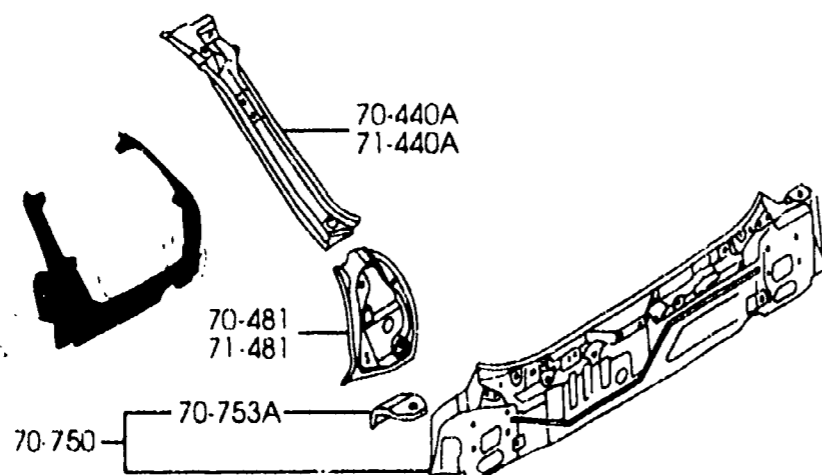

PART NO.	QTY	MODEL/RESTRICTION	MODEL/RESTRICTION	MODEL/RESTRICTION	FROM-TO
71-100A BL2L-71-100	1	PANEL(L), REAR PILLAR	PANNEAU(G), MONTANT A R		
71-11X BJ3K-71-11XA	1	PILLAR(L), REAR INNER	PILIER(G), INT AR.-AR		
71-114 B25D-71-112	1	PLATE(L), END	FLASQUE (G)		
71-120B B25R-71-120	1	REINF.(L), SUSPENSION HSG	RENFORT(G), LOGEM SUS PENS		
71-190A GE4T-70-46X	4	PLATE, NUT	PLAQUE, ECROU		
71-200 B2YR-71-20X	1	FRAME(L), SIDE-OUTER	CADRE LATERAL SUP.(G)		
71-210A B25D-71-230	1	PILLAR(L), HINGE	MONTANT DE CHARNIERE		
71-210C BJ0J-71-030	1	REINF.(L), HINGE	RENFORT CHARNIERE(G)		
71-260 B25D-71-240	1	PILLAR(L), FRT.-INNER	MONTANT INTERIEUR (G), AV		
71-270 B2YR-71-270	1	PANEL(L), SIDE SILL	PANNEAU(G), SEUIL LAT ERAL		
71-276 BJ0J-71-130B	1	REINF.(L), SIDE SILL	RENFORT		
71-350 B2YR-71-351	1	PILLAR(L), CTR.-OUTER	MONTANT CENTRAL (G), EXTE		
71-390 B50P-71-36Z	1	REINF.(L), 'B' PILLAR	RENFORT(G), PILIER 'B'		
71-410E B25R-71-113A	1	PANEL(L), REAR SIDE	PANNEAU LATERAL AR(G)		

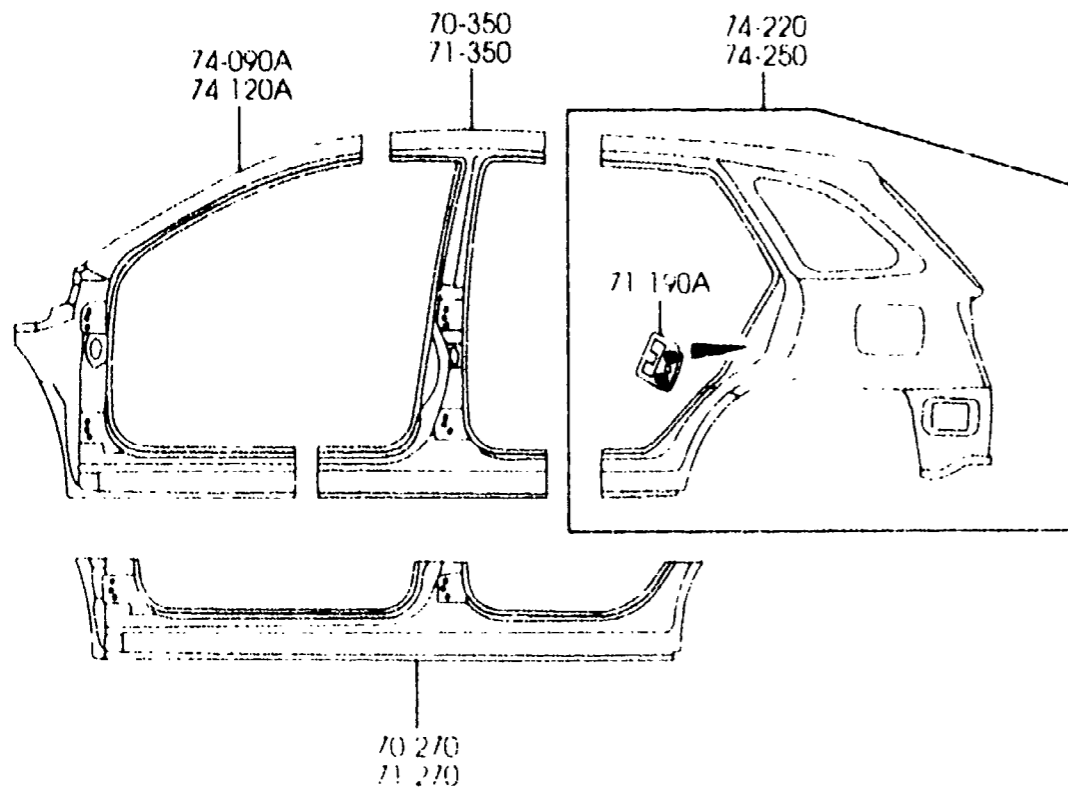
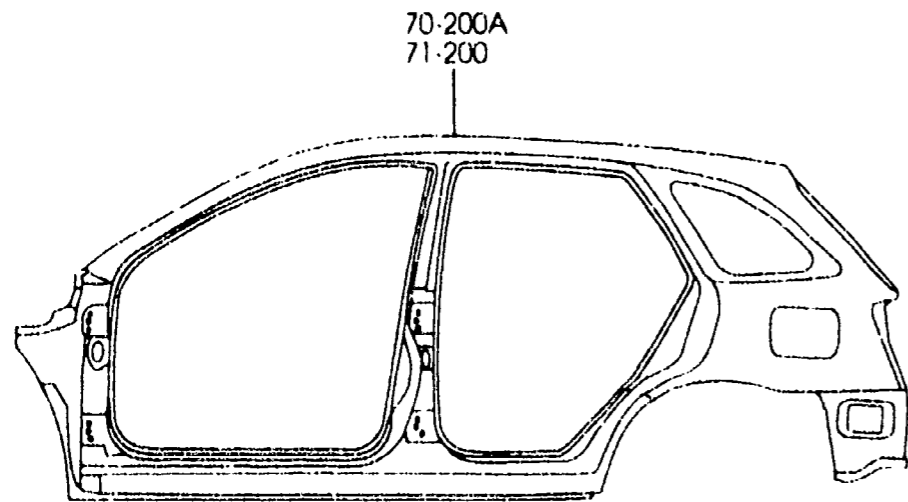

PART NO	QTY	MODFI/RESTRICTION	MODFI/RESTRICTION	MODEL/RESTRICTION	FROM-TO
71-420A B25R-71-180B	1	BRKT(L), ANCHOR-SEAT BELT	SUPPORT(G), ANCRE-CEI NTURE		
71-440A B25R-71-44X	1	PILLAR'D(L), OUT.-FENDER	PILIER'D(G), EXT.-P. CHOCS		
71-481 B25R-71-481	1	PLATE(L), CORNER	PLAQUE COIN(G)		
71-690 GE4T-71-16Y	1	GUSSET(L), WHEEL HOUS E	GOUSSET(G), LODGE. RO UE		
74-090A B2YR-70-221	1	PILLAR(R), FRONT-OUT.	MONTANT EXT, AV(D)		
74-120A B2YR-71-221	1	PILLAR(L), FRONT-OUT.	MONTANT EXT, AV(G)		
74-220 B2YR-70-410	1	PANEL(R), FENDER-REAR	PANNEAU(D), PARE-CHOC S ARR		
74-250 B2YR-71-410	1	PANEL(L), FENDER-REAR	PANNEAU(G), PARE-CHOC S ARR		



(W/O SUNROOF)

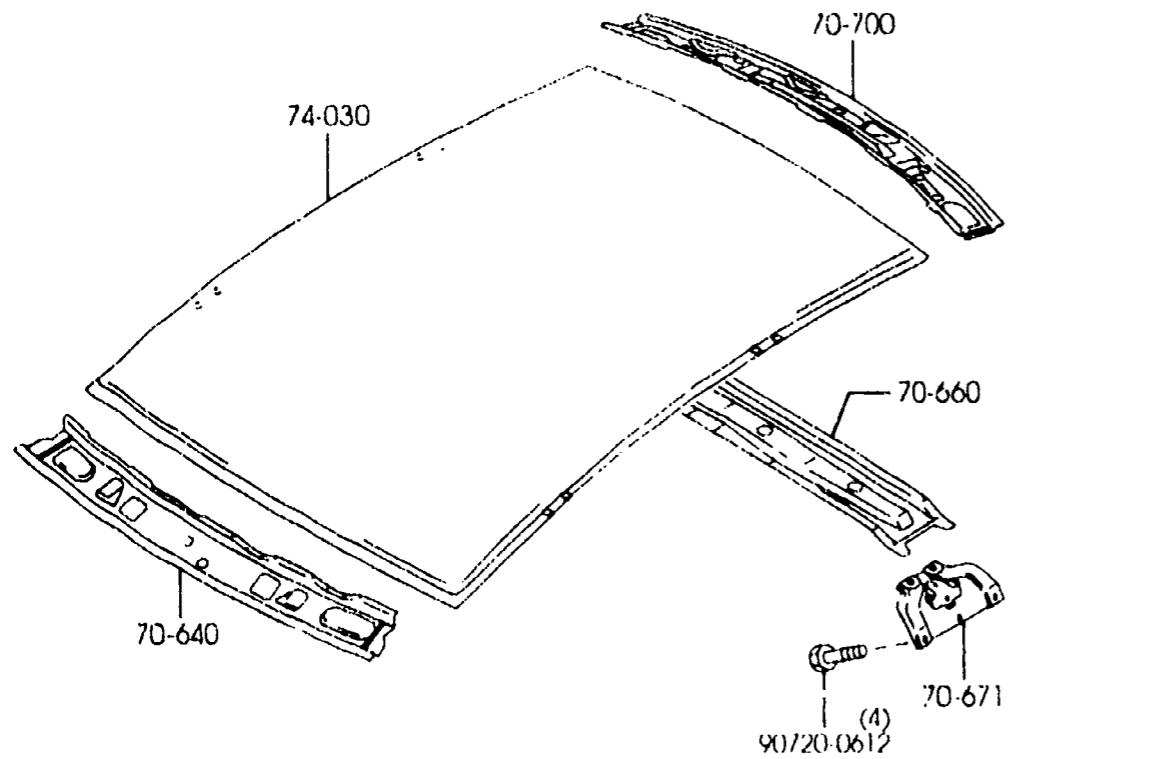

(W/SUNROOF)

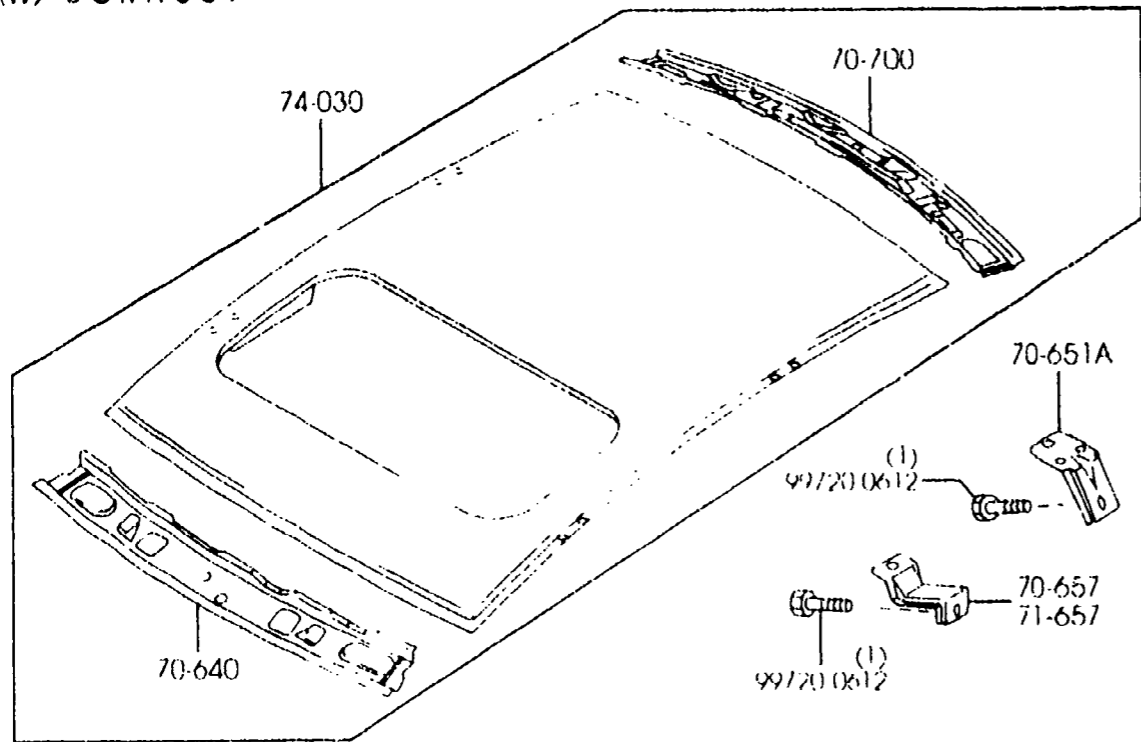

AUBA09

(2B53040)

PART NO.	QTY	MODEL/RESTRICTION	MODEL/RESTRICTION	MODEL/RESTRICTION	FROM-TO
70-640 B25D-70-641	1	HEADER, FRONT	RENFORT, AVT.		
70-651A B25K-70-623	2	BRACKET, S/ROOF (W/SUNROOF)	SUPPORT (TOIT OUVR)		
70-657 B25K-70-621	1	BRACKET(R), S/ROOF (W/SUNROOF)	SUPPORT(D) (TOIT OUVR)		
70-660 B25D-70-66XB	1	REINFORCEMENT, ROOF (W/O SUNROOF)	ARMATURE DE PAVILLON (TOIT NORMAL)		
70-671 B25D-70-635C	2	REINFORCEMENT, ROOF (W/O SUNROOF)	ARMATURE DE PAVILLON (TOIT NORMAL)		
70-700 B25D-70-700	1	HEADER, REAR	RENFORT, ARR.		
71-657 B25K-71-621	1	BRACKET(L), S/ROOF (W/SUNROOF)	SUPPORT (G) (TOIT OUVR)		
74-030 B2YK-70-60X B2YD-70-600	1 1	PANEL, ROOF (W/SUNROOF) (W/O SUNROOF)	PAVILLON (TOIT OUVR) (TOIT NORMAL)		

CAT. AUBA09-02

2001-07

(W/O SUNROOF)

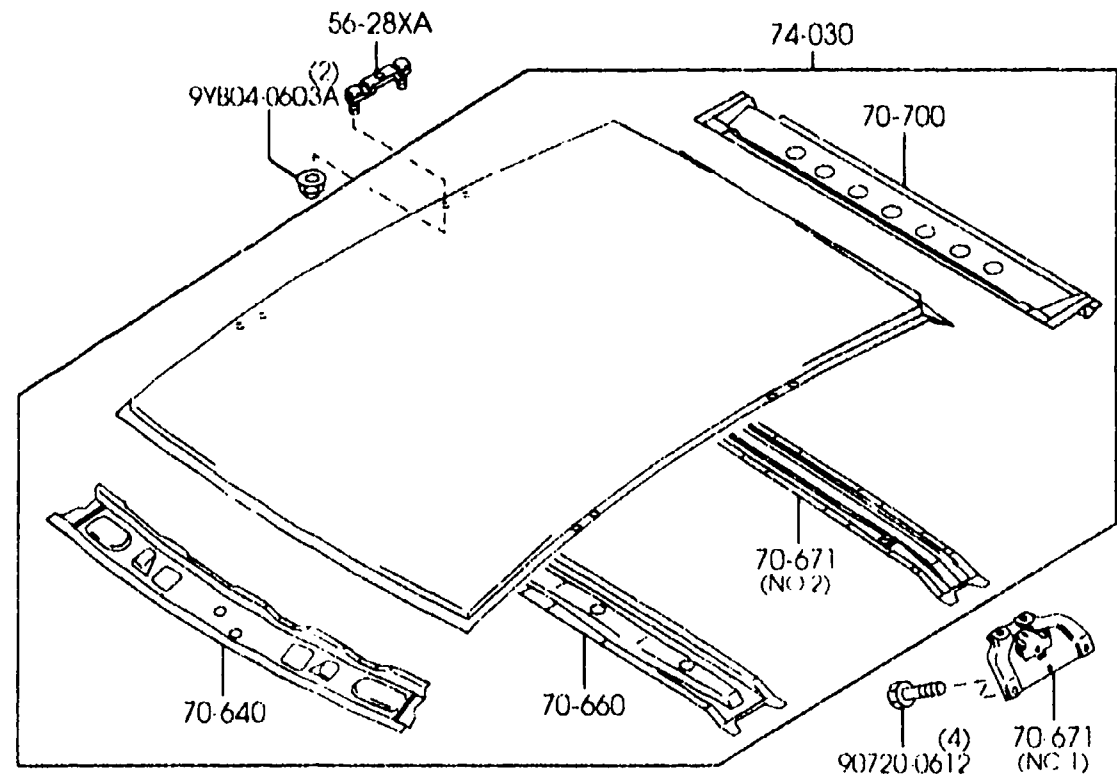

AUBA09

(2B66651)

(W/SUNROOF)

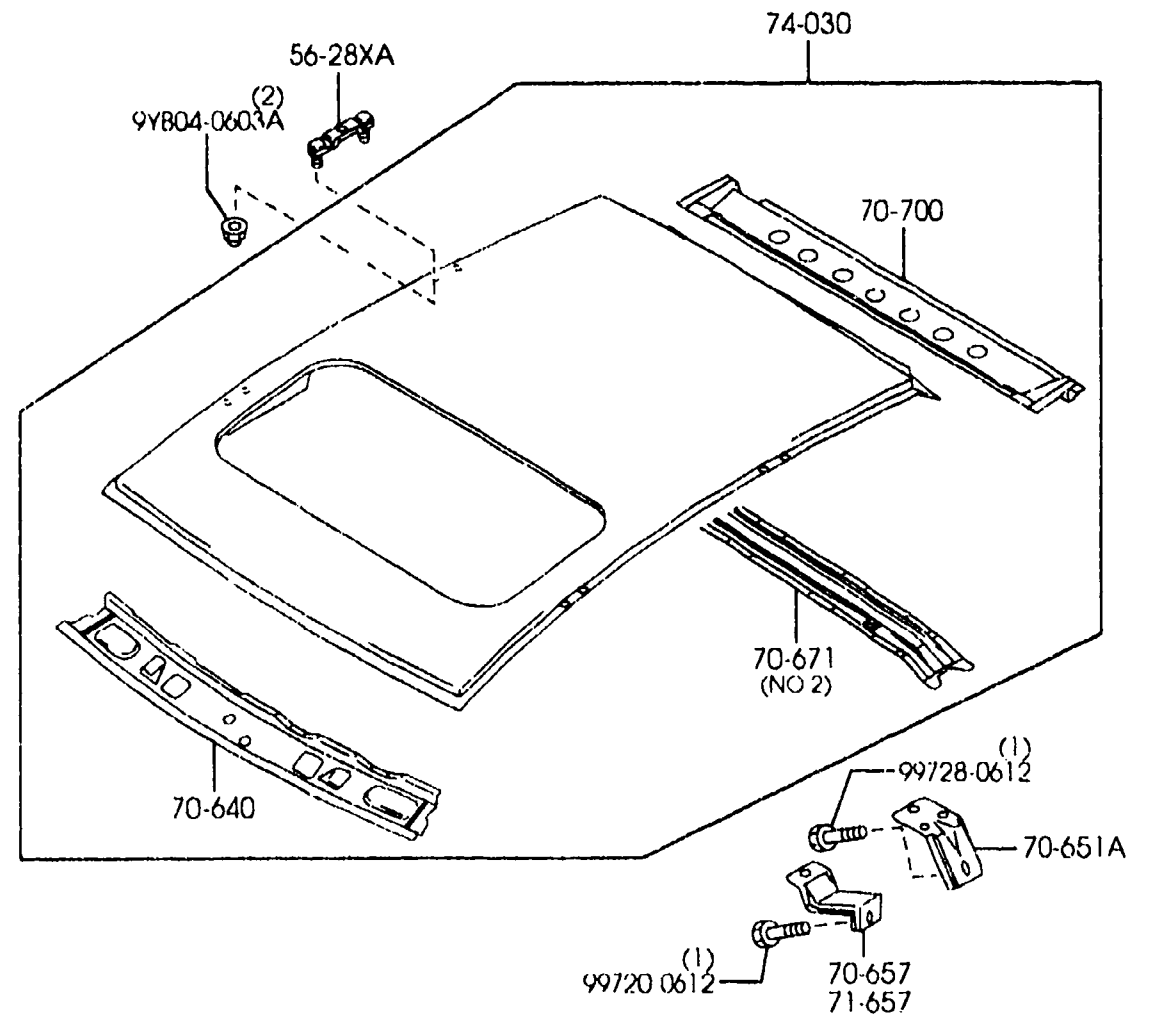

AUBA09

(2B66652)

(W/O SUNROOF)

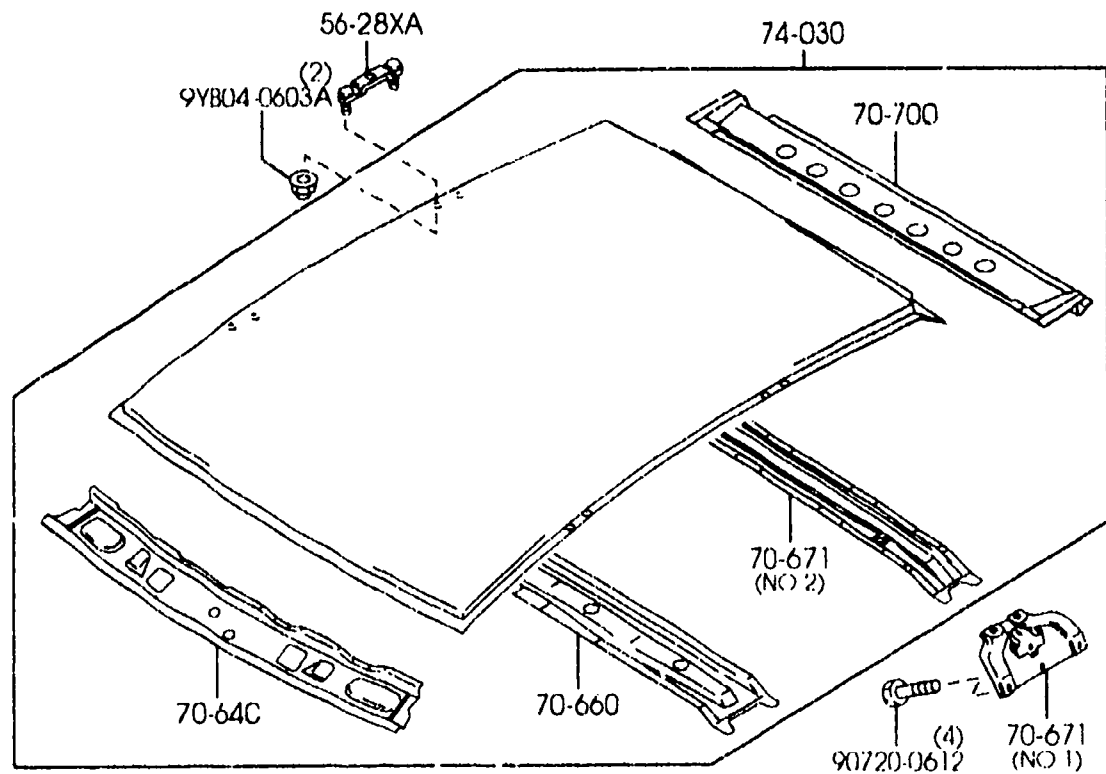

PART NO.	QTY	MODEL/RESTRICTION	MODEL/RESTRICTION	MODEL/RESTRICTION	FROM-TO
56-28XA		BRACKET SET	JEU SUPPORT, TOIT		
GF4K-56-28X	2	(W/ROOF RAIL)	(AVEC GALERIE)		
BJ3K-56-47Z	4	(W/O ROOF RAIL)	(SANS GALERIE)		
70-640		HEADER, FRONT	RENFORT, AVT.		
B25D-70-641	1				
70-651A		BRACKET, S/ROOF	SUPPORT		
B25K-70-623	2	(W/SUNROOF)	(TOIT OUVR)		
70-657		BRACKET(R), S/ROOF	SUPPORT(D)		
B25K-70-621	1	(W/SUNROOF)	(TOIT OUVR)		
70-660		REINFORCEMENT, ROOF	ARMATURE DE PAVILLON		
B25H-70-66XA	1	(W/O SUNROOF)	(TOIT NORMAL)		
70-671		REINFORCEMENT, ROOF	ARMATURE DE PAVILLON		
B25D-70-635C	2	(ILLUST. NO.1) (W/O SUNROOF)	(TOIT NORMAL)		
B25R-70-663	1	(ILLUST. NO.2)			
70-700		HEADER, REAR	RENFORT, ARR.		
B25R-70-700	1				
71-657		BRACKET(L), S/ROOF	SUPPORT (G)		
B25K-71-621	1	(W/SUNROOF)	(TOIT OUVR)		
74-030		PANEL, ROOF	PAVILLON		
*BJYE-70-60X	1	((W/O SUNROOF))>(W/O ROOF RAIL)	((TOIT NORMAL))>(SANS GALERIE)		
*BJVL-70-60X	1	((W/SUNROOF))>(W/O RO OF RAIL)	((TOIT OUVR))>(SANS G ALERIE)		
B2YR-70-60X	1	((W/O SUNROOF))>(W/RO OF RAIL)	((TOIT NORMAL))>(AVEC GALERIE)		
B2YW-70-60X	1	((W/SUNROOF))>(W/ROOF RAIL)	((TOIT OUVR))>(AVEC G ALERIE)		



5370A FL. OR PANELS  
(4 DOOR)

★ This part is not serviced.

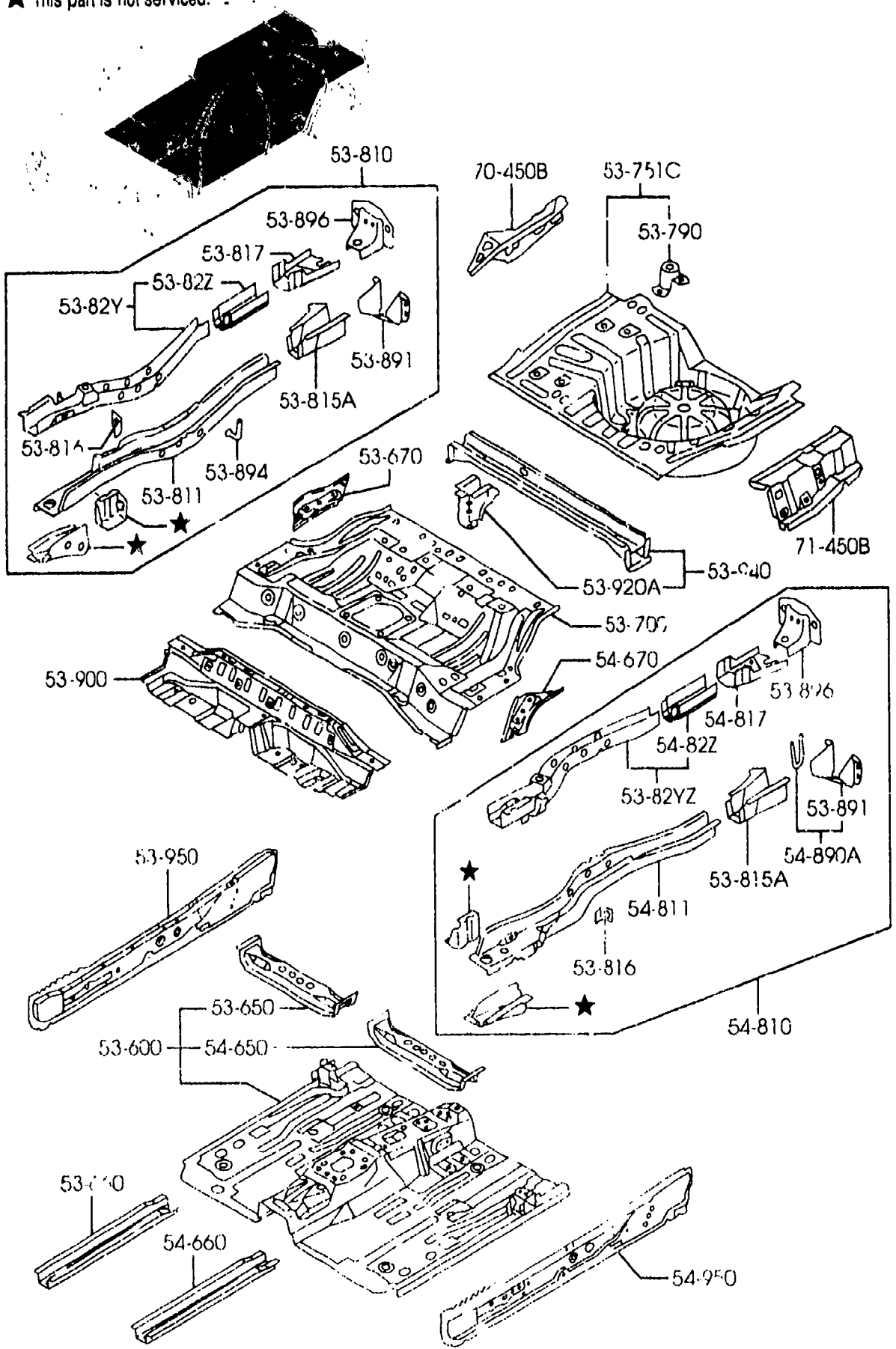

AUBA09

(2B53050)

5370A -1 FLOOR PANELS  
(4-DOOR)

PART NO.	QTY	MODEL/RESTRICTION	MODEL/RESTRICTION	MODEL/RESTRICTION	FROM TO
53-600		PAN, FLOOR-FRONT	PLANCHER AVANT		
BJ0J-53-600A	1				
53-650		MEMBER NO.2(R), CROSS-FLOOR	TRAVERSE NO.2(D), PLANC.		
GE4T-53-650A	1				
53-660		FRAME'B'(R), FRONT	CADRE AR(D),		
BJ0J-53-660	1				
53-670		BRKT(R), SEAT-F. FLOOR PAN	SUPPORT(D), SIEGE-BUTEE P.		
GA5R-53-7X0B AN(GA5R-53-7X0C)	1				1801-
*GA5R-53-7X0C	1				1801-
53-700		PAN, FLOOR-REAR	PLANCHER ARRIERE		
BLYC-53-70X	1				
53-751C		PAN, FLOOR-TRUNK	CUVETTE,		
B2YD-53-75X	1				
53-790		BRACKET, SPARE WHEEL	SUPPORT		
B531-53-790	1				
53-810		FRAME(R), REAR SIDE	ARMATURE (D), COTE A R.		
BJ0J-53-810C	1				
53-811		FRAME'A'(R), REAR SIDE	CHASSIS'A'(D), COTE A R.		
GE4T-53-811C	1				
53-815A		FRAME'B', REAR SIDE	CHASSIS'B', COTE AR.		
B25D-53-815B	2				
53-816		BRACKET	SUPPORT		
GA5P-53-892A	2				
53-817		REINF(R), REAR FRAME	RENFORT'B'(D), CHASSIS AR		
B25D-53-817B	1				
53-82Y		REINF(R), REAR FRAME	RENFORT(D), CADRE AR		
BJ0J-53-820A	1				

CAT. AUBA09-02

2001-07

5370A FLOOR PANELS  
(4-DOOR)

5370A -2 FLOOR PANELS  
(4-DOOR)

★ This part is not serviceable

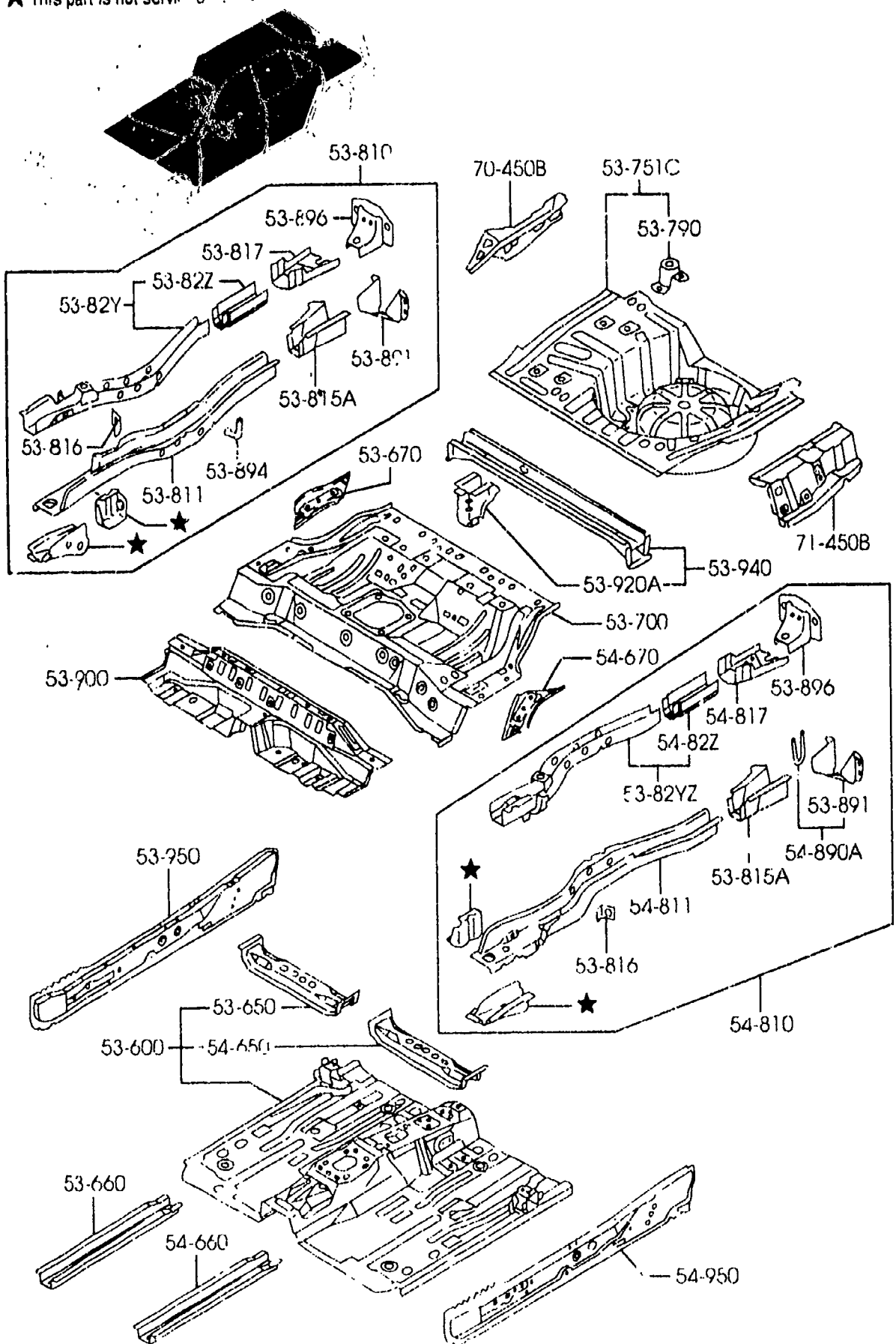

PART NO.	QTY	MODEL/RESTRICTION	MODEL/RESTRICTION	MODEL/RESTRICTION	FROM -10
53-82YZ		REINF(L), REAR FRAME	RENFORT(G), CADRE AR		
BJ0J-54-820A	1				
53-82Z		REINF (R), FRAME-REAR	RENFORT(D), CHASSIS-A R.		
BJ0J-53-82ZA	1				
53-891		BRACKET, HOOK	SUPPORT, CROCHET		
GJ21-53-891F	2				
53-894		HOOK, SILENCER	CROCHET, SILENCIEUX		
B25D-53-894	1				
53-896		BRACKET, R. BUMPER UPP ER	CONSOLE, P-CHOCS AR-S UP		
GJ21-53-896R	2				
53-900		MEMBER NO.3, CROSS	TRAVERSE NO 3		
BJ0J-53-900	1				
53-920A		BRACKET, TANK	SUPPORT (A)		
GE4T-53-92ZA	1				
53-940		MEMBER NO.4, CROSS	TRAVERSE NO 4		
B78V-53-920D	1				
53-950		PANEL(R), SIDE SILL	LONGERON EXT. (D)		
GE8K-53-950C	1				
54-650		MEMBER NO.2(L), CROSS -FLOOR	TRAVERSE NO.2(G), PLANC.		
B25D-54-650	1				
54-660		FRAME'B'(L), FRONT	CADRE AR(G),		
BJ0J-53-660	1				
54-670		BRKT(L), SEAT-F. FLOOR PAN	SUPPORT(G), SIEGE-BUT EE P.		
GA5R-54-7XJB AN(GA5R-54-7X0C)	1				-1201
GA5R-54-7X0C A (GA5R-54-7X0D)	1				1201-1216
GA5R-54-7X0D AN(GA5R-54-7X0E)	1				1216-1801
*GA5R-54-7X0E	1				1801-
1201 BJ22* -430345					
1216 BJ22* -436221					

AUBA09

(2B53050)

CAT. AUBA09-02

2001-07

3-N 9

5370A FLOOR PANELS  
(4-DOOR)

5370A -3 \* FLOOR PANELS  
(4-DOOR)

★ This part is not serviced.

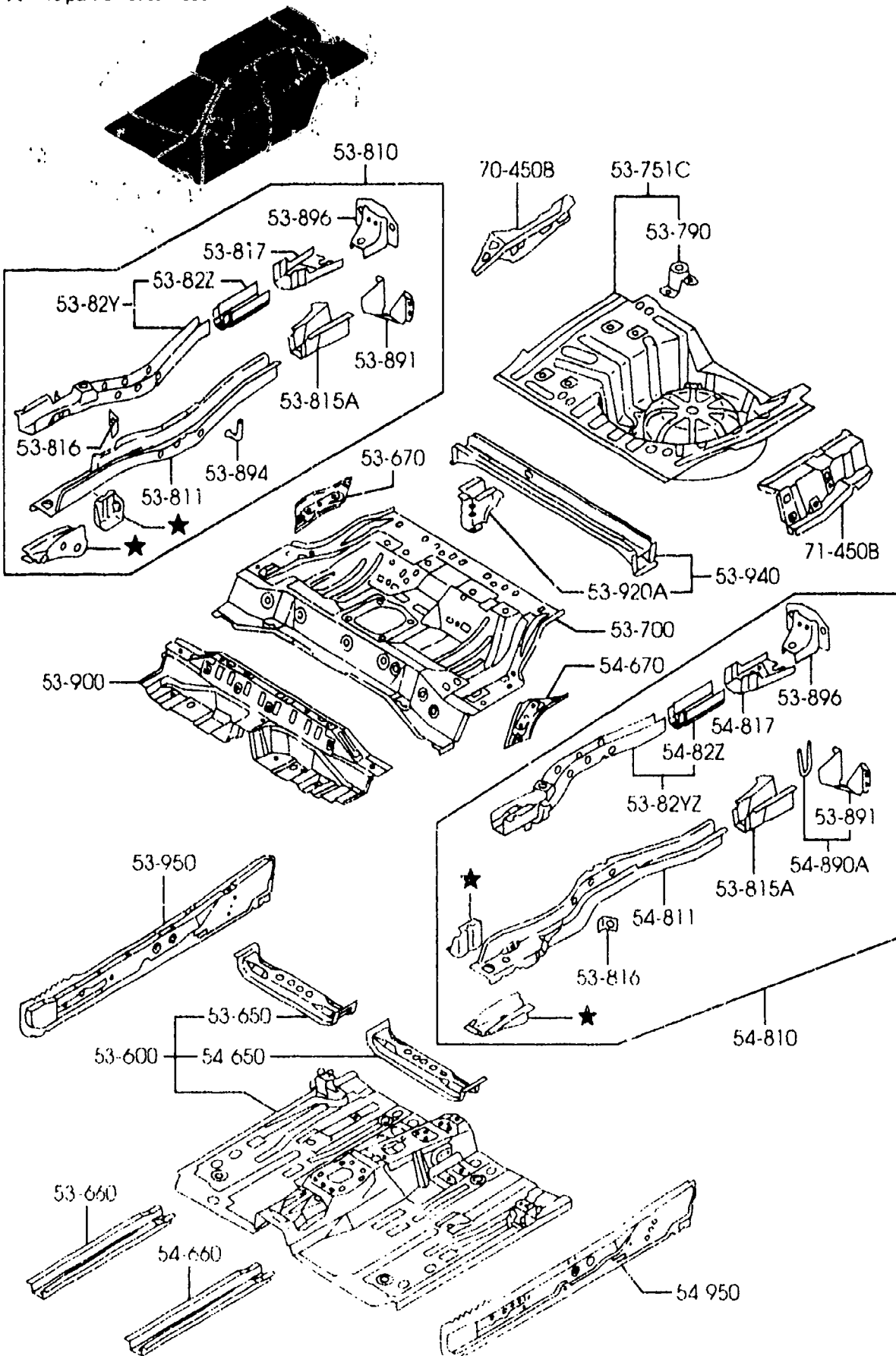

PART NO.	QTY	MODEL/RESTRICTION	MODEL/RESTRICTION	MODEL/RESTRICTION	FROM-TO
54-810	1	FRAME(L), REAR SIDE	ARMATURE (G), COTE A R.		
BL8D-54-810	1				
54-811	1	FRAME'A'(L), REAR SIDE	CHASSIS'A'(G), COTE A R.		-1110
GE4T-54-811D	1				
A (GE4T-54-811E)	1				
GE4T-54-811E	1				1110-
54-817	1	REINF(L), REAR FRAME	RENFORT'B'(G), CHASSIS AR		
BJ0J-54-81XA	1				
54-822	1	REINF (L), FRAME-REAR	RENFORT(G), CHASSIS-A R.		
BJ0J-54-82ZA	1				
54-890A	1	BRACKET, HOOK	CROCHET(G), POINT FIX ATION		
BL8D-54-890	1				
54-950	1	PANEL(L), SIDE SEAL	LONGERON EXT. (G)		
GE8K-54-950C	1				
70-450B	1	PANEL(R), FLOOR SIDE	PANNEAU INF. (D)		
B25D-53-730	1				
71-450B	1	PANEL(L), FLOOR SIDE	PANNEAU LATERAL(G),		
B25D-54-731A	1				
1110 BJ22* -420731					

AUBA09

(2B53050)

CAT. AUBA09-02

2001-07

5370B FLOOR PANELS  
(5-DOOR)

★ This part is not serviced.

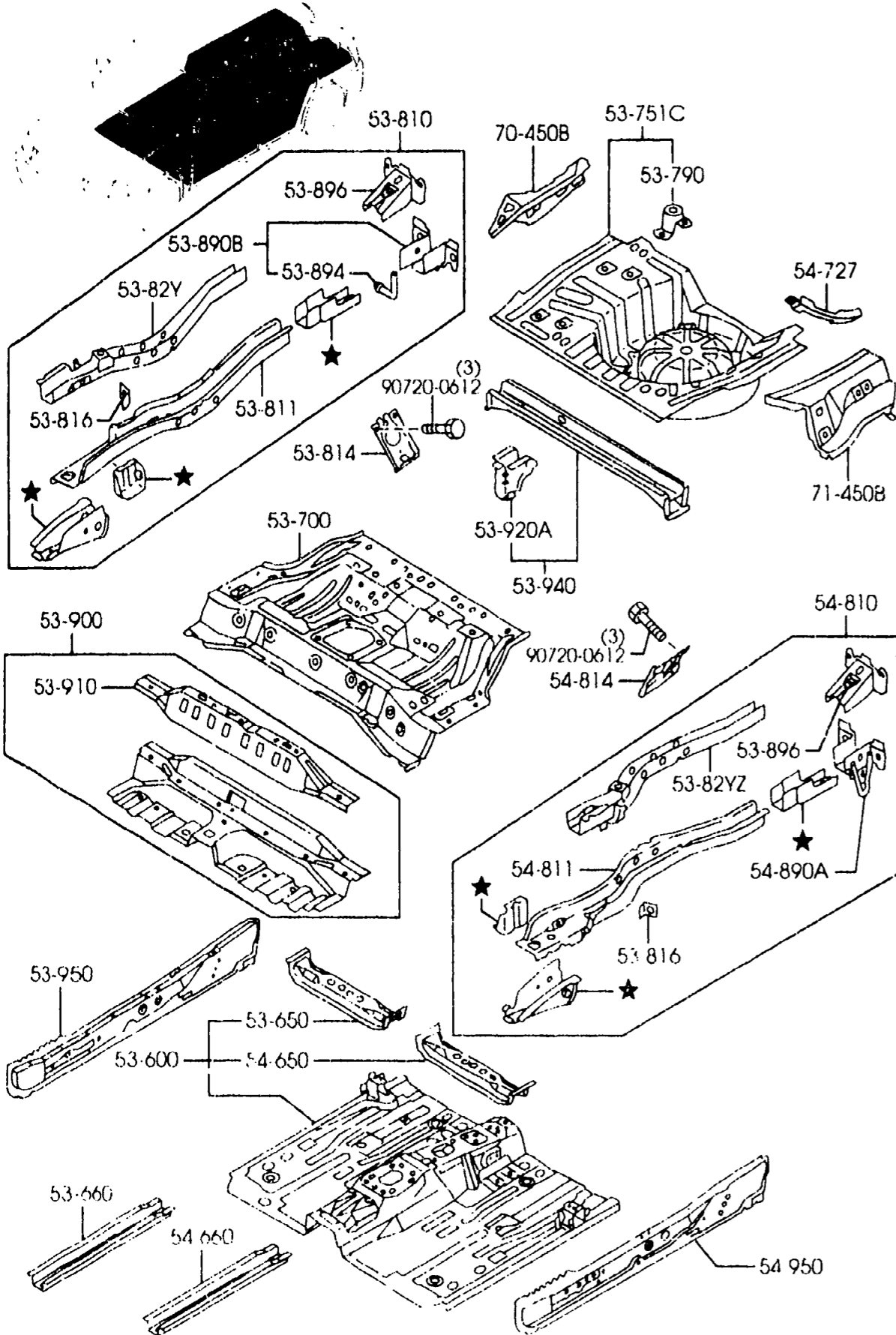

AUBA09

(2B58800)

5370B -1 FLOOR PANELS  
(5-DOOR)

PART NO.	QTY	MODEL/RESTRICTION	MODEL/RESTRICTION	MODEL/RESTRICTION	FROM-TO
53-600		PAN,FLOOR-FRONT	PLANCHER AVANT		
BJ0J-53-600A	1				
53-650		MEMBER NO.2(R),CROSS-FLOOR	TRAVERSE NO.2(D),PLANC.		
GE4T-53-650A	1				
53-660		FRAME'B'(R),FRONT	CADRE AR(D),		
BJ0J-53-660	1				
53-700		PAN,FLOOR-REAR	PLANCHER ARRIERE		
BNYV-53-70X	1				
53-751C		PAN,FLOOR-TRUNK	L VETTE,		
BNYV-53-75X	1				
53-790		BRACKET,SPARE WHEEL	SUPPORT		
B531-53-790	1				
53-810		FRAME(R),REAR SIDE	ARMATURE (D), COTE A R.		
BN5V-53-810	1				
53-811		FRAME'A'(R),REAR SIDE	CHASSIS'A'(D),COTE A R.		
GE4T-53-811C	1				
53-814		BRACKET(R)	ATTACHE (D)		
GE4T-53-729A	1				
53-816		BRACKET	SUPPORT		
GA5R-53-892A	2				
53-82Y		REINF(R),REAR FRAME	RENFORT(D),CADRE AR		
BN5V-53-820	1				
53-82YZ		REINF(L),REAR FRAME	RENFORT(G),CADRE AR		
BN5V-54-820	1				
53-890B		BRACKET,HOOK	CROCHET&CONSOLE,CADRE AR.		
BN5V-53-890	1				
53-894		HOOK,SILENCER	CROCHET,SILENCIEUX		
B25D-53-894	1				

CAT. AUBA09-02

2001-07

5370B FLOOR PANELS  
(5-DOOR)

★ This part is not serviced.

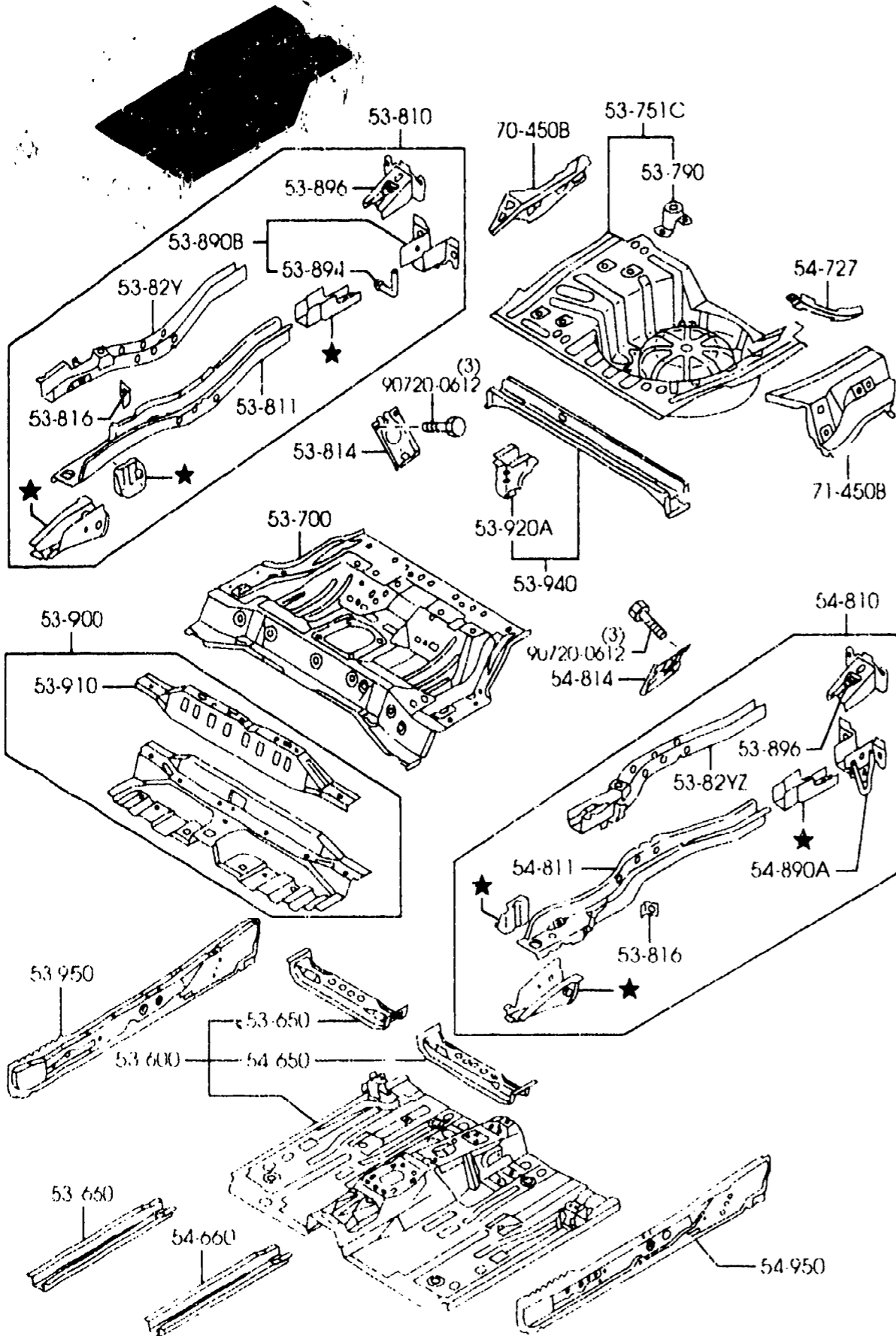

AUBA09

(2B58800)

5370B-2 FLOOR PANELS  
(5-DOOR)

PART NO.	QTY	MODEL/RESTRICTION	MODEL/RESTRICTION	MODEL/RESTRICTION	FROM-TO
53-896 B25R-53-89X	2	BRACKET, R. BUMPER-UPPER	CONSOLE, P-CHOCES AR-SUP		
53-900 BJ3K-53-900	1	MEMBER NO. 3, CROSS	TRAVERSE NO 3		
53-910 B25R-53-910	1	MEMBER NO. 3, CROSS-UPPER	MEMBER NO. 3, TRAVERSE-SUP.		
53-920A GE4T-53-922A	1	BRACKET, TANK	SUPPORT (A)		
53-940 BN5V-53-920A	1	MEMBER NO. 4, CROSS	TRAVERSE NO 4		
53-950 BN5V-53-950	1	PANEL (R), SIDE SILL	LONGERON EXT. (D)		
54-650 B25D-54-650	1	MEMBER NO. 2(L), CROSS-FLOOR	TRAVERSE NO. 2(G), PLANC.		
54-660 BJ0J-53-660	1	FRAME 'B' (L), FRONT	CADRE AR (G),		
54-727 CB01-54-727	1	REINF (L), REAR FLOOR	RENFORT SOL ARRIERE (G)		
54-810 BN5V-54-810	1	FRAME (L), REAR SIDE	ARMATURE (G), COTE AR.		
54-811 GE4T-54-811E	1	FRAME 'A' (L), REAR SIDE	CHASSIS 'A' (G), COTE AR.		
54-814 GE4T-54-729A	1	BRACKET (L)	SUPPORT (G)		
54-890A BN5V-54-890	1	BRACKET, HOOK	CROCHET (G), POINT FIXATION		
54-950 BN5V-54-950	1	PANEL (L), SIDE SEAL	LONGERON EXT. (G)		

CAT. AUBA09-02

2001-07



5370B FLOOR PANELS  
(5-DOOR)

5370B -3 \* FLOOR PANELS  
(5-DOOR)

★ This part is not serviced.

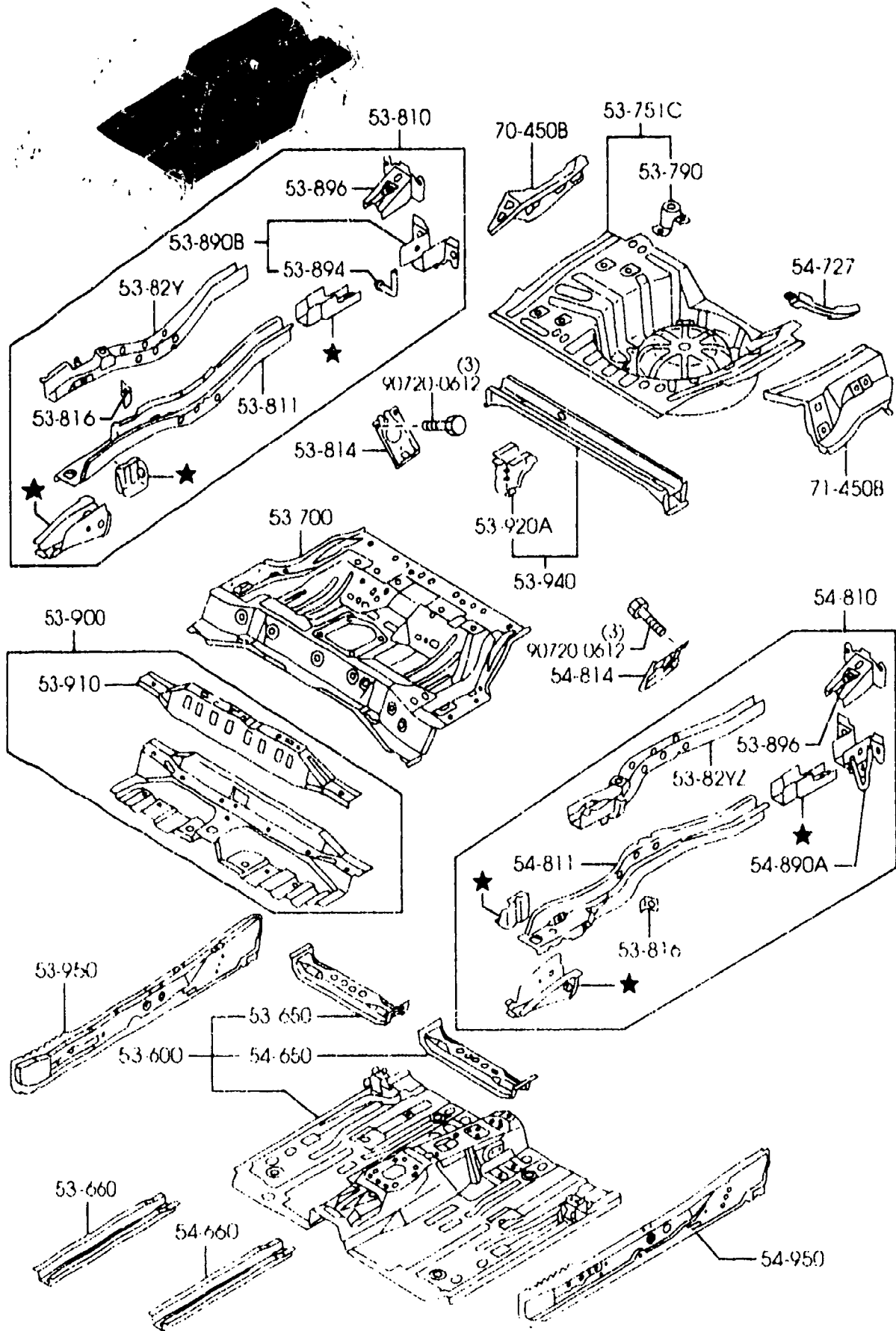

PART NO.	QTY	MODEL/RESTRICTION	MODEL/RESTRICTION	MODEL/RESTRICTION	FROM-TO
70-450B		PANEL(R), FLOOR SIDE	PANNEAU INF.(D)		
BJ3K-53-731	1				
71-450B		PANEL(L), FLOOR SIDE	PANNEAU LATERAL(G),		
BJ3K-54-731A	1				

AUBA09

(2B58800)

CAT. AUBA09-02

2001-07

3-F10

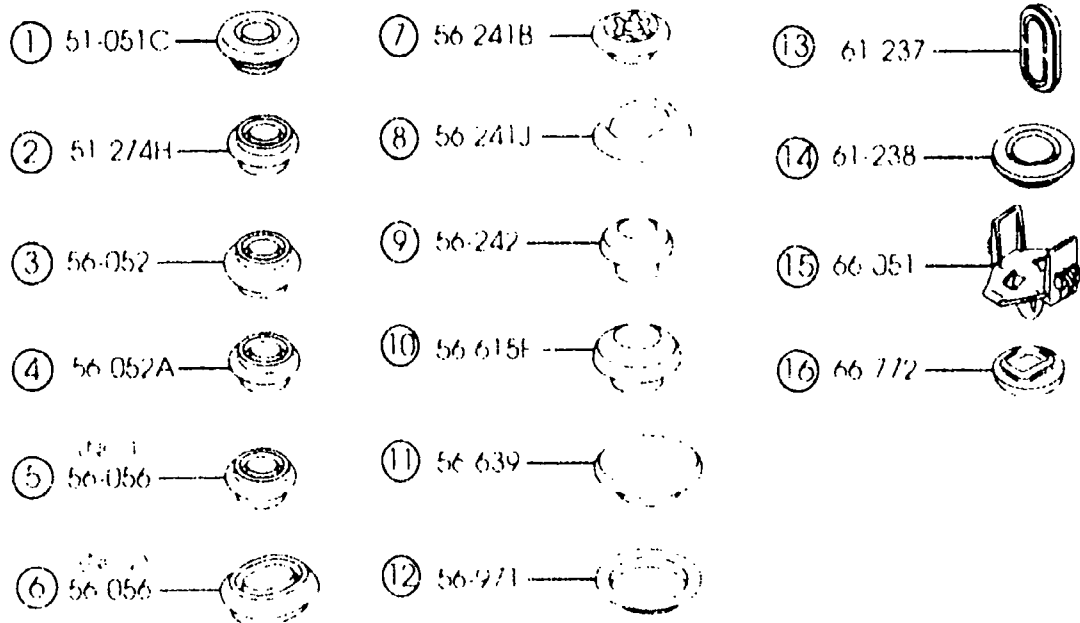
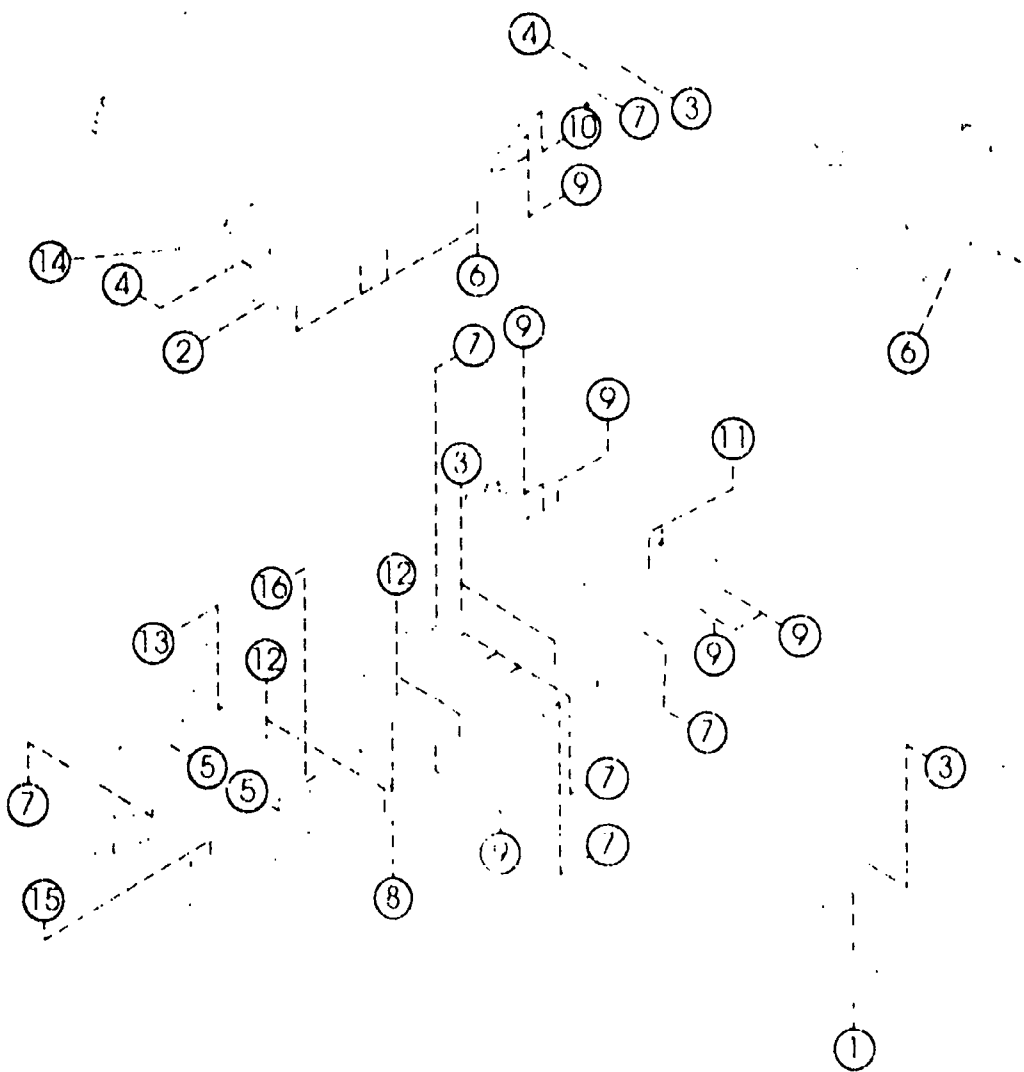

PART NO.	QTY	MODEL/RESTRICTION	MODEL/RESTRICTION	MODEL/RESTRICTION	FROM TO
51-051C BR70-51-264	2	PLUG, HOLE	BOUCHON D'ORIFICE		
51-274H BF67-51-261	2	GRUMMET	ANNEAU		
56-052 B092-56-052	6	PLUG, DRAIN D=12MM	BOUCHON DE VIDANGE D=12MM		
56-052A H260-56-052	4	PLUG, HOLE-F. SIDE FRAME (W/O SUNROOF)	BOUCHON, TROU-CADRE LAT AV. (TOIT NORMAL)		
56-056 GA5R-56-052 T001-56-053	2 10	COVER, HOLE (ILLUST. NO.1) (ILLUST. NO.2)	COUVERCLE, TROU		
56-241B B001-56-051	11	PLUG	BOUCHON		
56-241J B477-56-241	1	PLUG, DRAIN	BOUCHON DE VIDANGE		
56-242 0118-56-242B	10	PLUG, DRAIN	BOUCHON DE VIDANGE		
56-615F 0208-56-615	2	PLUG, DRAIN	BOUCHON DE VIDANGE		
56-639 0810-56-639	2	COVER, SERVICE HOLE	CHAPEAU, ORIFICE DE VISITE		
56-971 0866-56-971	4	COVER, HOLE	BOUCHON		
61-237 GA5R-61-237	1	GRUMMET, DASH PANEL LOWER (W/O AIR CON.)	BAGUE, TABLIER INFRIEUR		
61-238 GE8C-61-238	1	GRUMMET, REAR FLOOR (W/O AIR CON.)	BAGUE, PLANCHE ARRIERE		

5380A FLOOR ATTACHMENT (HOLE COVERS)  
(4-DOOR)

5380A -2 \* FLOOR ATTACHMENT (HOLE COVERS)  
(4-DOOR)

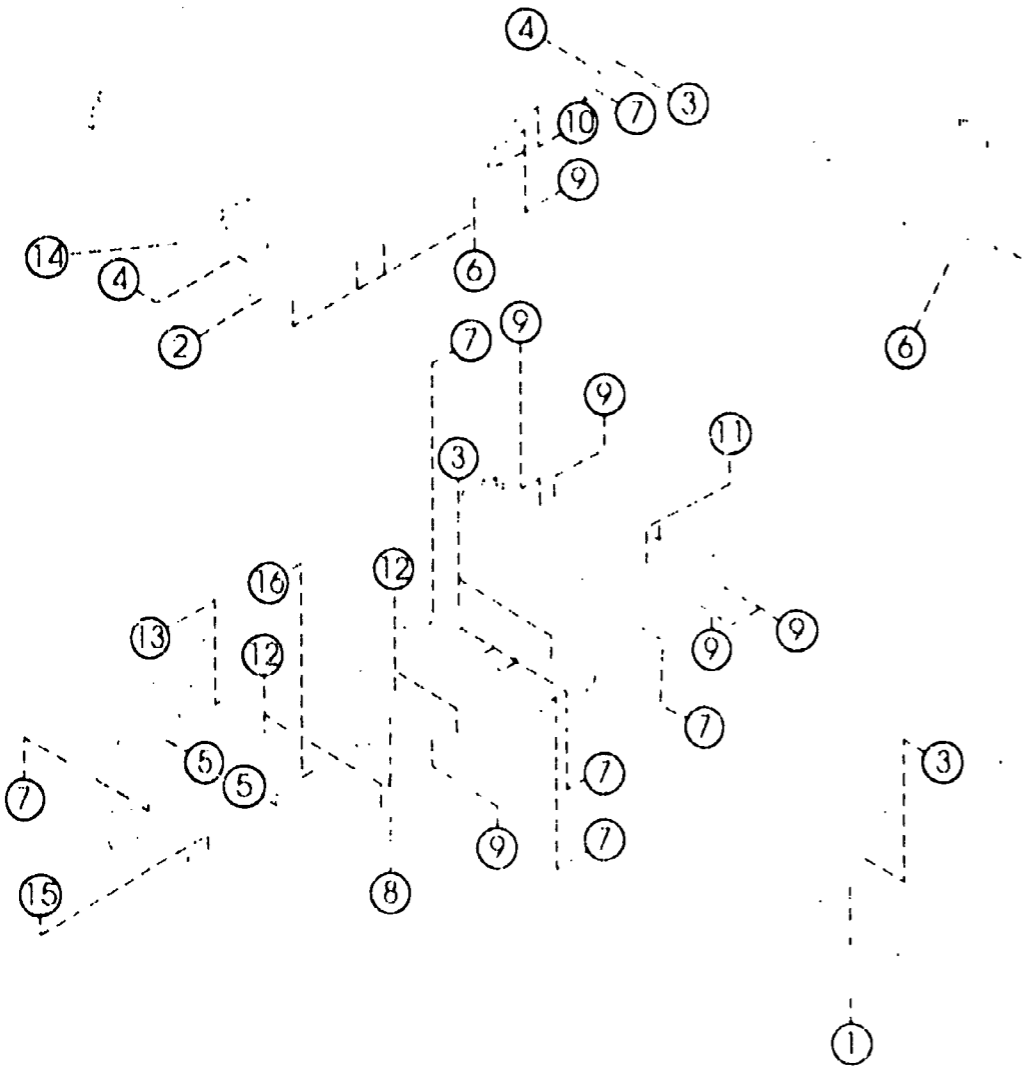

- |             |             |            |
|-------------|-------------|------------|
| ① 51-051C — | ⑦ 56-241B — | ⑬ 61-237 — |
| ② 51-274H — | ⑧ 56-241J — | ⑭ 61-238 — |
| ③ 56-052 —  | ⑨ 56-242 —  | ⑮ 66-051 — |
| ④ 56-052A — | ⑩ 56-615F — | ⑯ 66-772 — |
| ⑤ 56-056 —  | ⑪ 56-639 —  |            |
| ⑥ 56-056 —  | ⑫ 56-971 —  |            |

PART NO.	QTY	MODEL/RESTRICTION	MODEL/RESTRICTION	MODEL/RESTRICTION	FROM-TO
66-051		CAP	BOUCHON		
B02A-67-KW1	1	(W/O AIR CON.)			
66-772		GROMMET	COUVERCLE		
B092-41-661	1	(W/O AUTO CRUISE CON T.)			

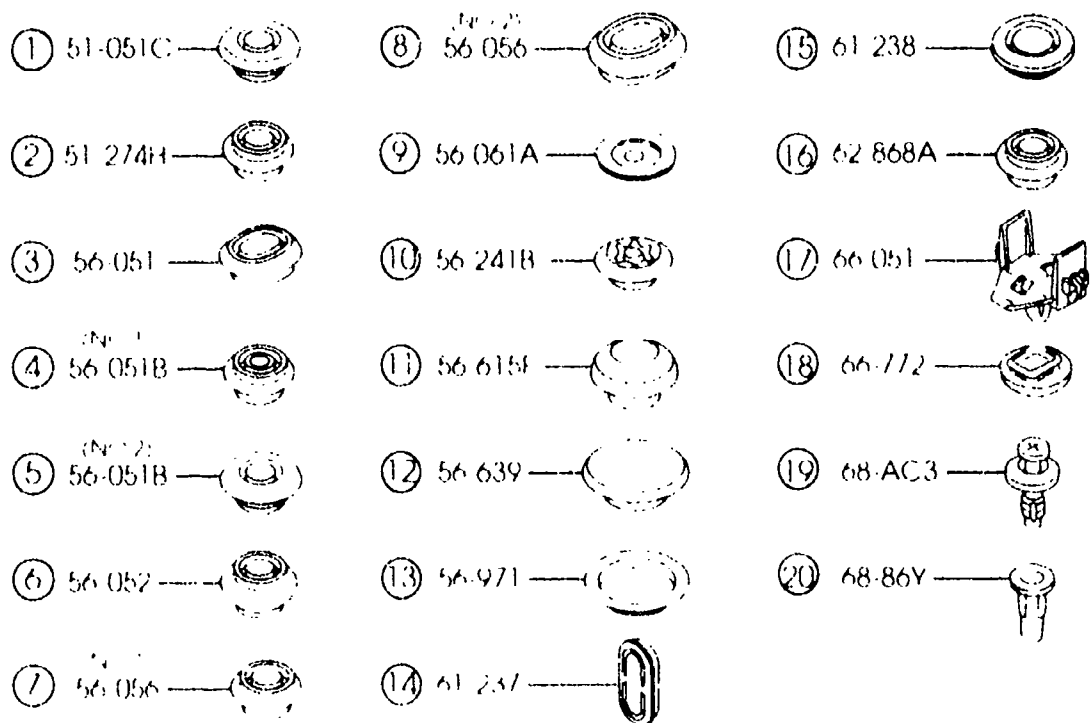
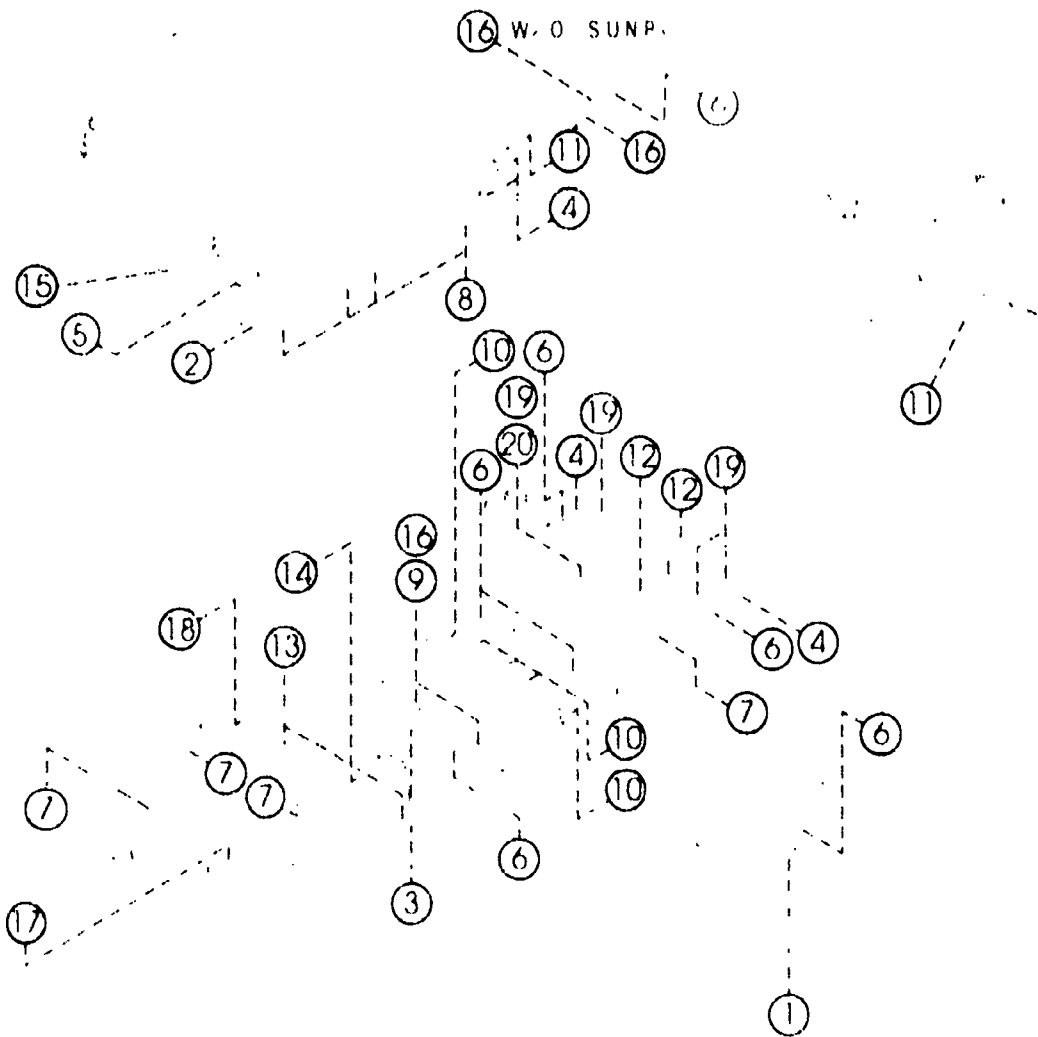

AUBA09

(2B58810)

PART NO.	QTY	MODEL/RESTRICTION	MODEL/RESTRICTION	MODEL/RESTRICTION	FROM-TO
51-051C BR70-51-264	2	PLUG,HOLE	BOUCHON D'ORIFICE		
51-274H BF67-51-261	2	GROMMET	ANNEAU		
56-051 BC1D-56-052	1	COVER,HOLE	BOUCHON		
56-051B GA5R-56-051	6 (ILLUST. NO.1)	COVER,HOLE	COUVERCLE,TROU		
T001-56-052	2 (ILLUST. NO.2) (W/O SUNROOF)		BOIT NORMAL)		
56-052 B092-56-052	9	PLUG,DRAIN D=12MM	BOUCHON DE VIDANGE D=12MM		
56-056 GA5R-56-052	6 (ILLUST. NO.1)	COVER,HOLE	COUVERCLE,TROU		
T001-56-053	8 (ILLUST. NO.2)				
56-061A 8545-56-052	2	COVER,HOLE	COUVERCLE,TROU		
56-241B B001-56-051	5	PLUG	BOUCHON		
56-615F 0208-56-615	4	PLUG,DRAIN	BOUCHON DE VIDANGE		
56-639 0810-56-639	2	COVER,SERVICE HOLE	CHAPEAU, ORIFICE DE VISIT		
56-971 0866-56-971	2	COVER,HOLE	BOUCHON		
61-237 GA5R-61-237	1	GROMMET,DASH PANEL LOWER (W/O AIR CON.)	BAGUE,TABLIER INFERIEUR		
61-238		GROMMET,REAR FLOOR	BAGUE,PLANCHE ARRIERE		

CAT. AUBA09-02

2001-07

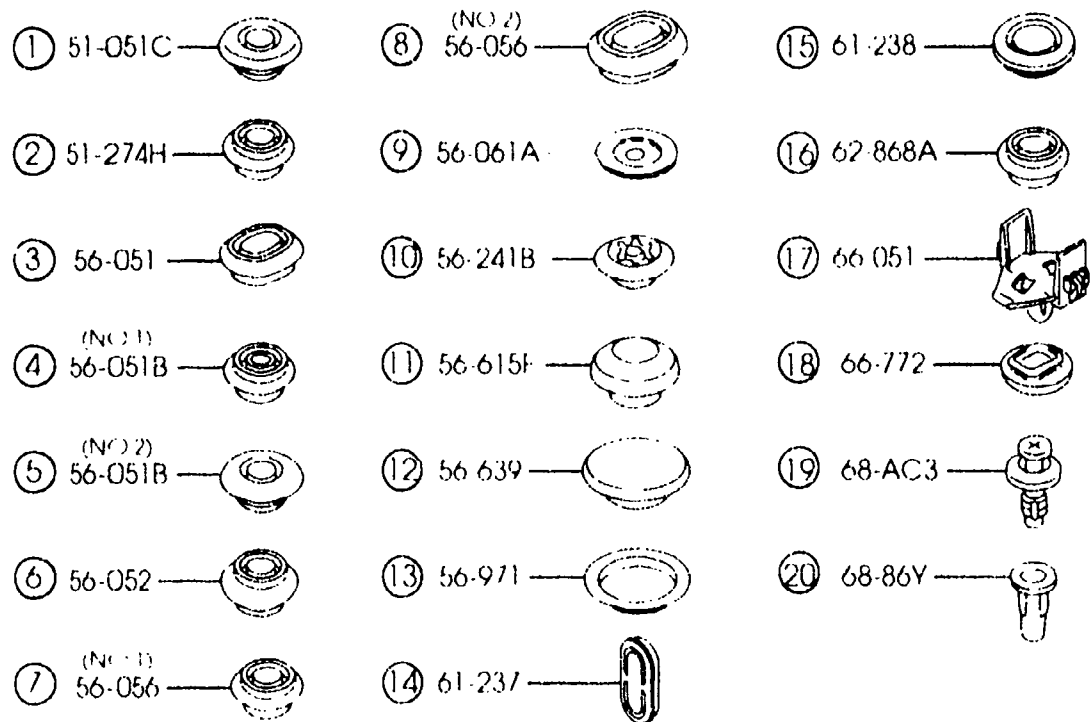
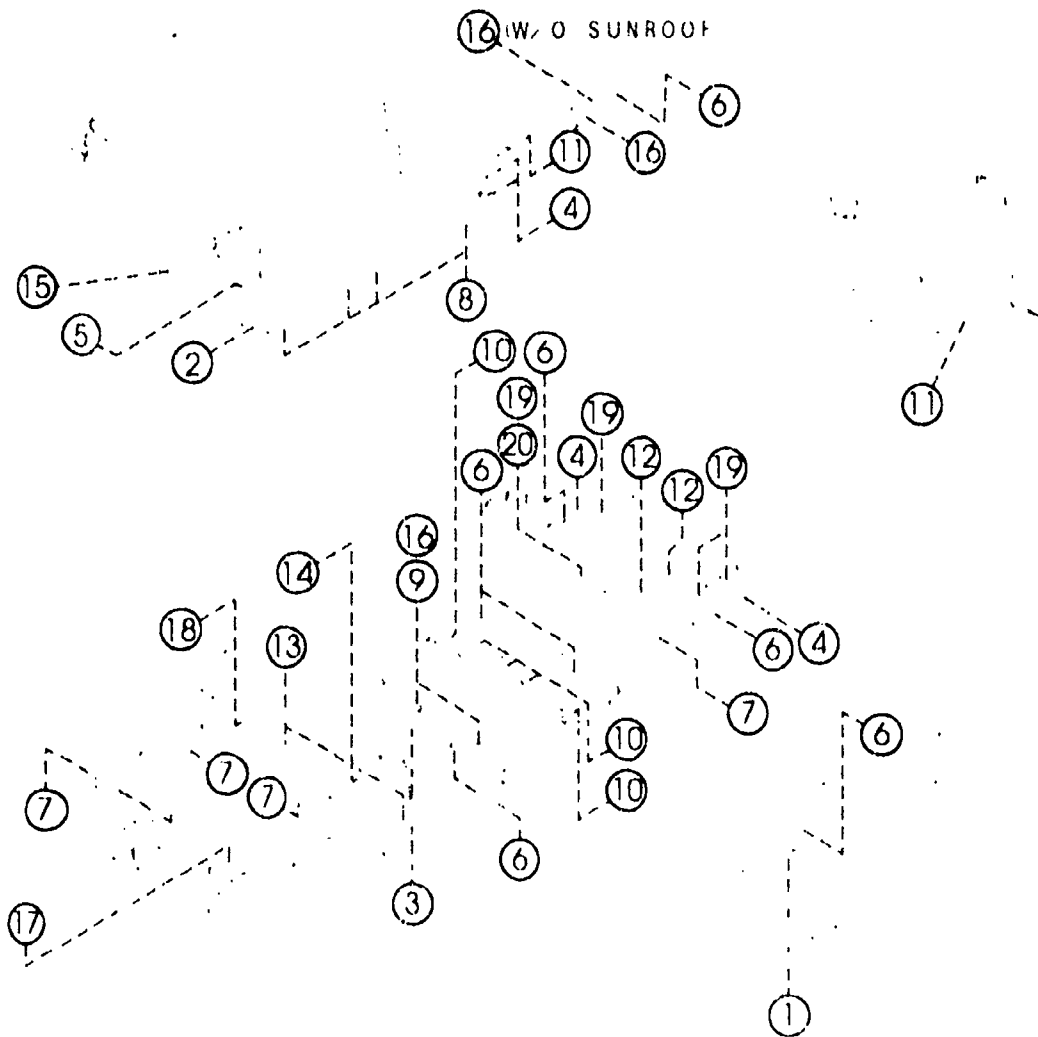

PART NO.	QTY	MODEL/RESTRICTION	MODEL/RESTRICTION	MODEL/RESTRICTION	FROM-TO
CONT'D GEBC-61-238	1	(W/O AIR CON.)			
↑-----↑   62-868A   ↑-----↑		COVER,HOLE-LIFT GATE	COUVERCLE, TROU-PORTE		
B499-62-868	4	(W/SUNROOF)	ARR. (TOIT OUVR)		
B499-62-868	6	(W/O SUNROOF)	(TOIT NORMAL)		
↑-----↑   66-051   ↑-----↑		CAP	BOUCHON		
B02A-67-KW1	1	(W/O AIR CON.)			
↑-----↑   66-772   ↑-----↑		GRUMMET	COUVERCLE		
B092-41-661	1	(W/O AUTO CRUISE CON T.)			
↑-----↑   68-AC3   ↑-----↑		FASTENER	AGRAFE		
B467-68-AC3	4				
02	INT-	BN4 BLACK	BN4 NOIR		
↑-----↑   68-86Y   ↑-----↑		CAP, SEAL-TRUNK END T RIM	CAPUCHON, ETANC.-GARN .COFF		
KA01-68-86YA	1				



5390A FLOOR ATTACHMENT  
(4-DOOR)

5390A -2 FLOOR ATTACHMENT  
(4-DOOR)

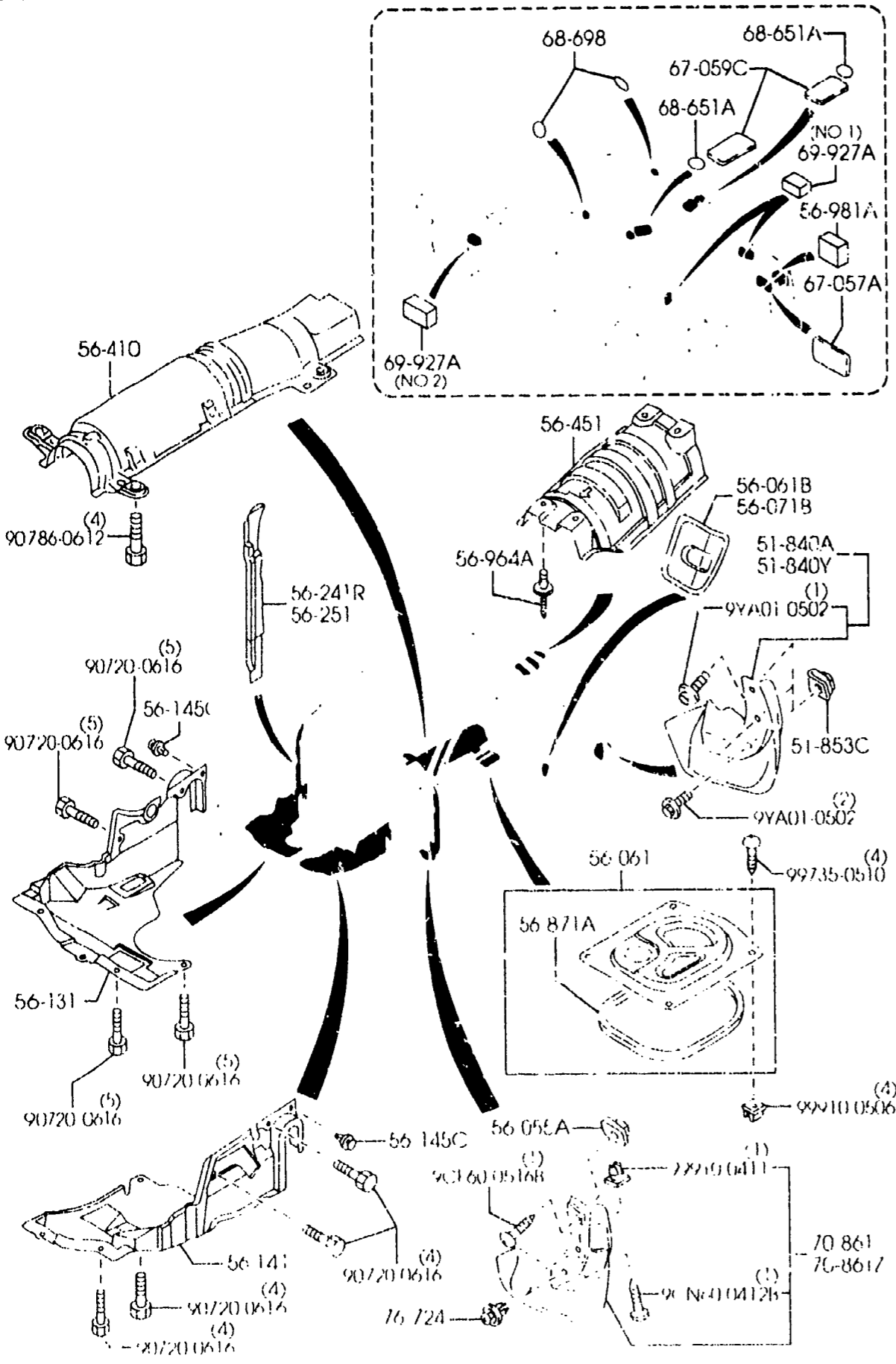

PART NO.	QTY	MODEL/RESTRICTION	MODEL/RESTRICTION	MODEL/RESTRICTION	FROM-TO
56-251 B25D-56-396E	1	PLATE(L), SEAL-F.FEND ER (2000)	PLAQUE(G), JOINT-AILE AV. (2000)		
56-410 GE4T-56-441D	1	INSULATOR, HEAT-FRONT	ISOLANT THERMIQUE AV		
56-451 B25D-56-451B A (B25D-56-451C)	1	INSULATOR	ISOLATEUR		-0B29
56-871A GE4T-56-072A	1	RUBBER, SEAL	JOINT CAOUTCHOUC		0B29-
56-964A B25D-56-398	4	RIVET, SEAL PLATE-SHR UD	RIVET, PLAQUE ETANCH. HAUD.		
56-981A B25E-69-927A	1	INSULATOR	ISOLATEUR		
67-057A R14S-56-994	1	PAD, JACK BRACKET	TAMPON, SUPPORT DE CR IC		
67-059C GU01-67-059	2	PAD, PROTECTOR	PELOTE, PROTECTEUR		
68-651A GJ21-68-651	2	INSULATOR, BACK PANEL -FRT	ISOLIERABDECKUNG -FRT		
68-698 GJ21-68-698	2	COVER, HOLE	COUVERCLE, TROU		
69-927A B25D-69-927	2	INSULATOR, PKG. JUNCT ION (ILLUST. NO.1) (W/O SUNROOF)	ISOLANT, RACCORD. EMB ALL. (TOIT NORMAL)		
H360-69-927A	2	(ILLUST. NO.2)			
70-861 BJOE-51-840	1	FLAP(R), FRONT (W/MUD FLAP) (SPORT SUSP)	BAVETTE AV (D) (SUSP. SPORTIVE)		
0B29 BJ22* -404914					

AUBACC

(2B53760)

CAT. AUBA09-02

2001-07

5390A FLOOR ATTACHMENT  
(4-DOOR)

5390A -3 \* FLOOR ATTACHMENT  
(4-DOOR)

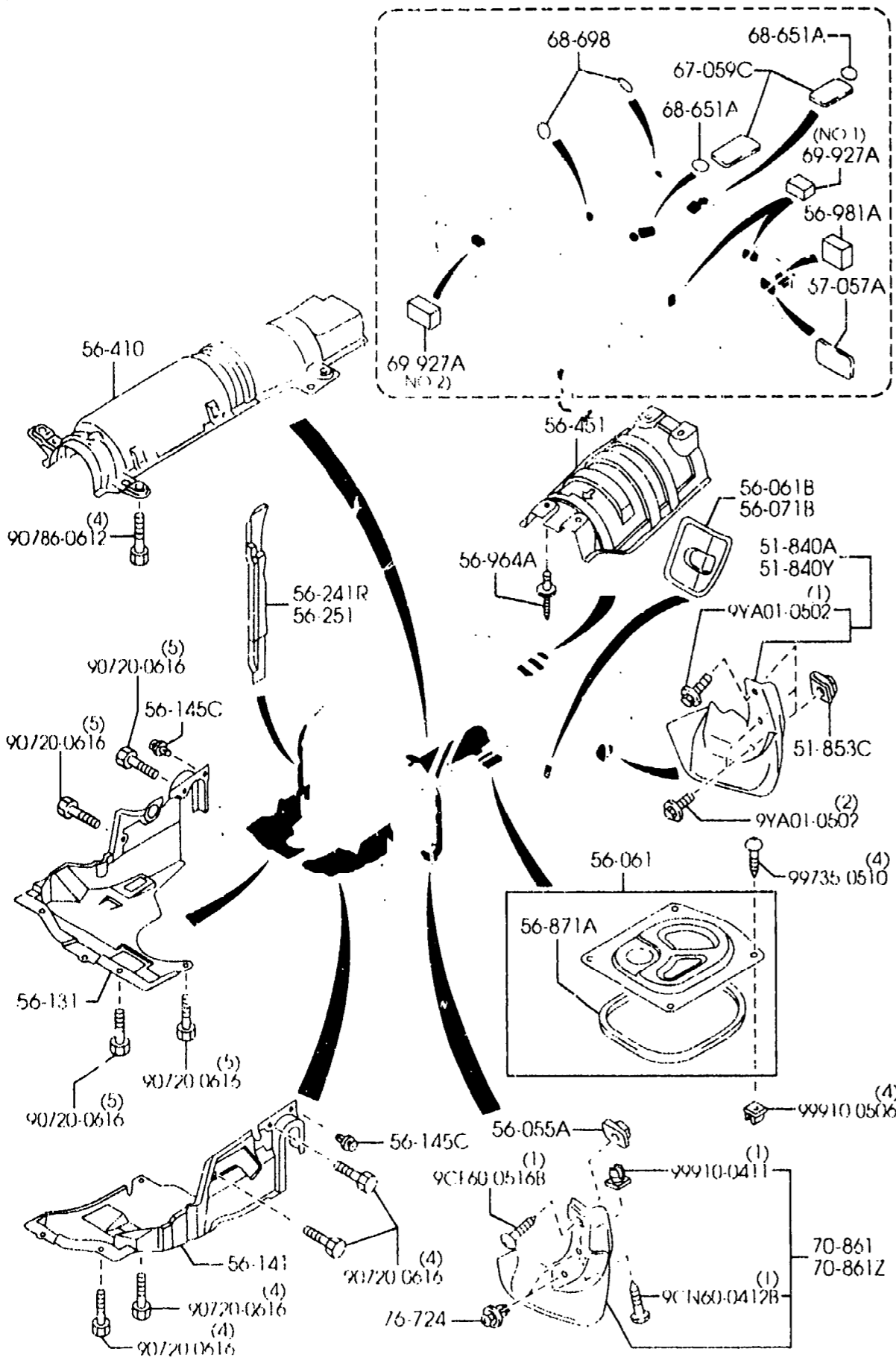

PART NO.	QTY	MODEL/RESTRICTION	MODEL/RESTRICTION	MODEL/RESTRICTION	FROM-TO
70-861Z		FLAP(L),FRONT	BAVOLET AV(G)		
BJ0E-51-050	1	(W/MUD FLAP) (SPORT SUSP)	(SUSP. SPORTIVE)		
76-724		RIVET	RIVET		
3092-51-833	4	(W/MUD FLAP)			

AUBA09

(2B53060)

CAT. AUBA09-02

2001-07

3-M10



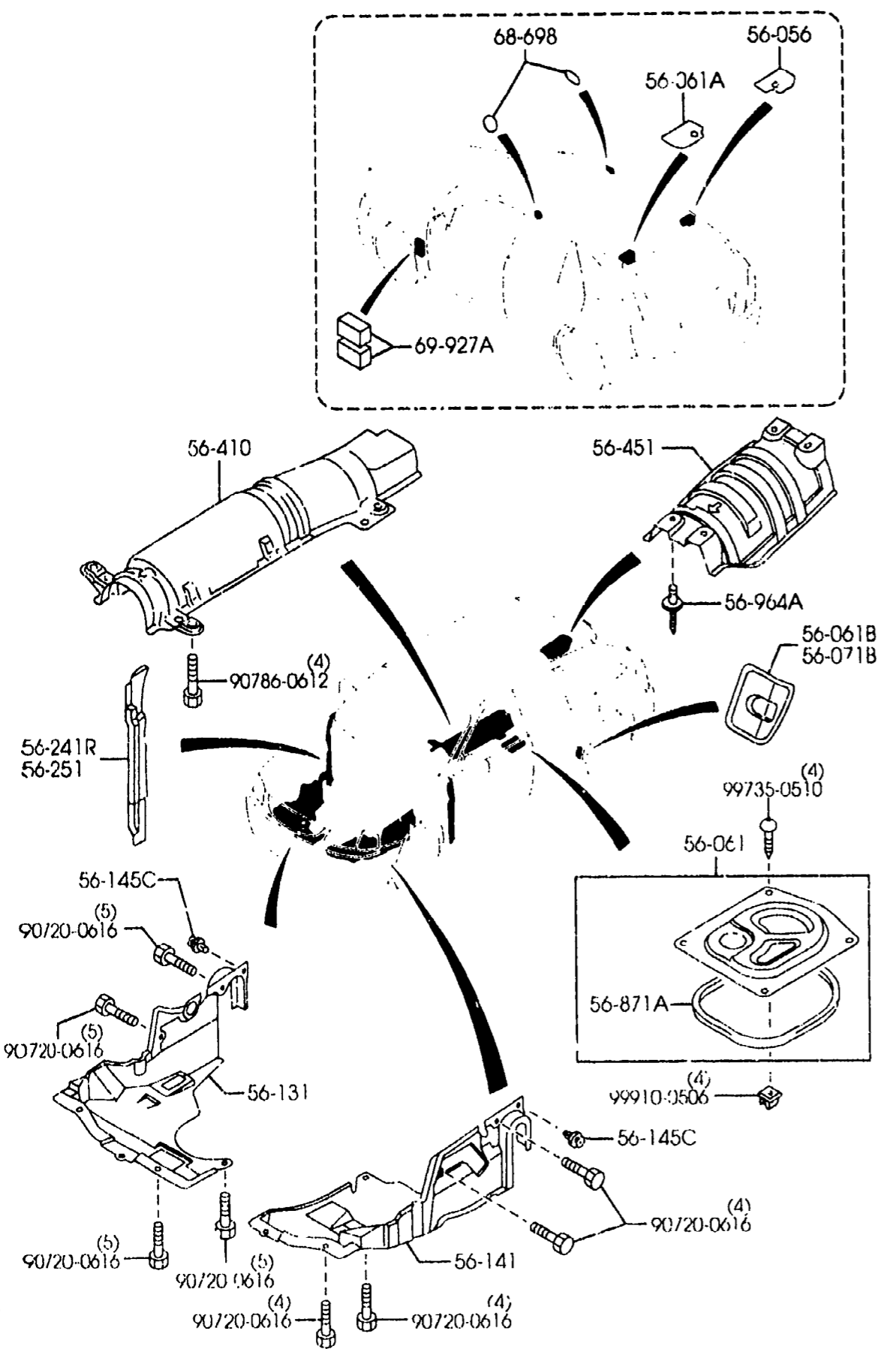

PART NO.	QTY	MODEL/RESTRICTION	MODEL/RESTRICTION	MODEL/RESTRICTION	FROM-TO
56-056		COVER, HOLE	COUVERCLE, TROU		
B25H-56-078A	1				
56-061		COVER, SERVICE HOLE	CHAPEAU, ORIFICE DE VISIT		
GE4T-56-070B	1				
56-061A		COVER, HOLE	COUVERCLE, TROU		
B25H-56-079A	1				
56-061B		COVER(R), SIDE-DECK	COUVERCLE(D), COTE-PO NT AV		
B25D-56-061D	1				
65	INT-	BN4 OFF-BLACK	BN4 NOIR CLAIR		
56-071B		COVER(L), SIDE-DECK	COUVERCLE(G), COTE-CO UV.		
B25D-56-065D	1				
65	INT-	BN4 OFF-BLACK	BN4 NOIR CLAIR		
56-131		SHIELD(R), SPLASH	BOUCLIER (D)		
B25D-56-321J	1				
56-141		SHIELD(L), SPLASH	BOUCLIER (G)		
B25D-56-341H	1				
56-145C		CLIP, MUD GUARD	ETRIER, GARDE BOUE		
BC1D-56-145	2				
56-241R		PLATE(R), SEAL-F.FEND ER	PLAQUE(D), JOINT-AILE AV.		
B25D-56-391E	1				
56-251		PLATE(L), SEAL-F.FEND ER	PLAQUE(G), JOINT-AILE AV.		
B25D-56-396E	1				
56-410		INSULATOR, HEAT-FRONT	ISOLANT THERMIQUE AV		
GE4T-56-441D	1				
56-451		INSULATOR	ISOLATEUR		
B25D-56-451C	1				
56-871A		RUBBER, SEAL	JOINT CAOUTCHOUC		
GE4T-56-072A	1				

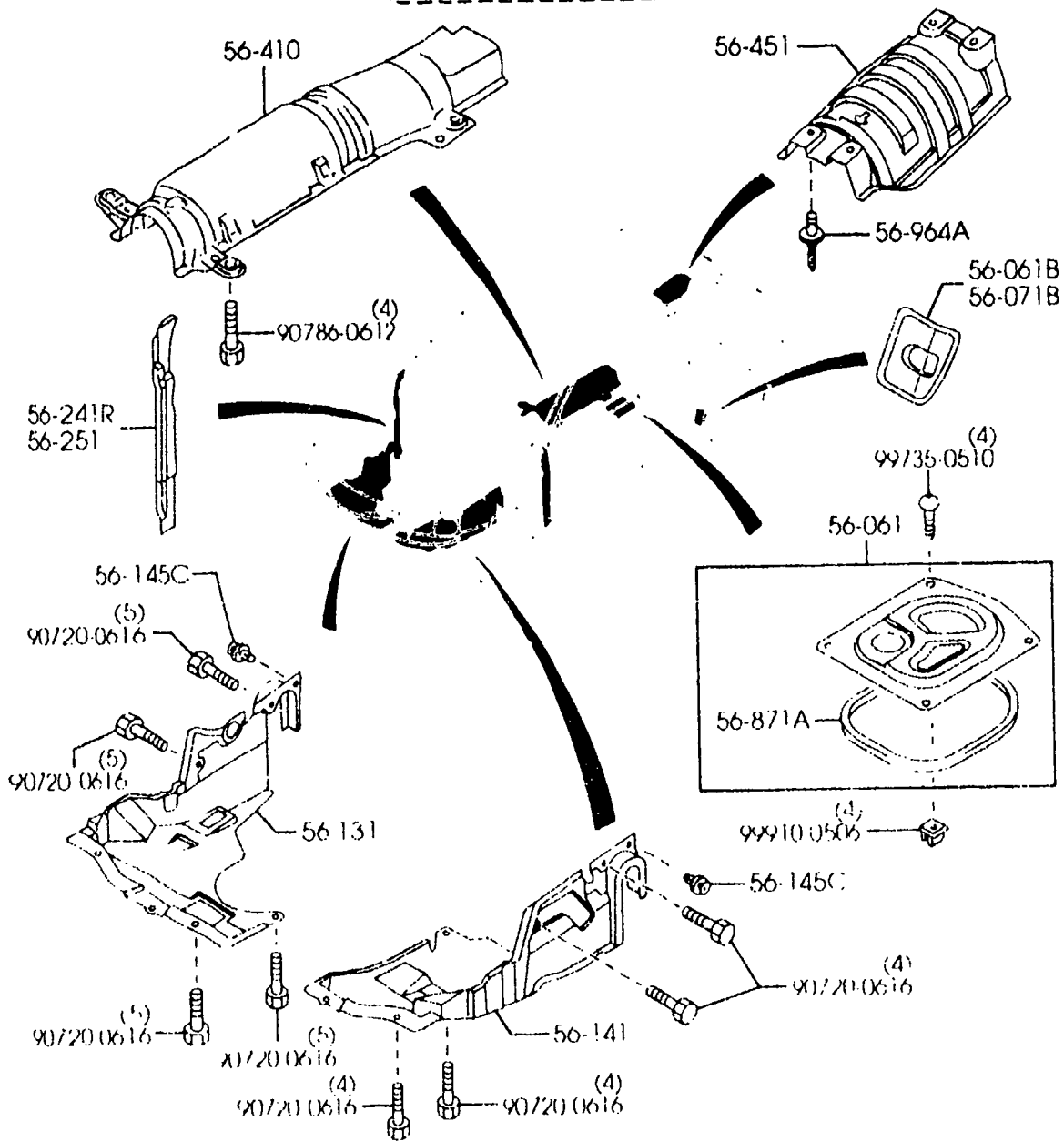
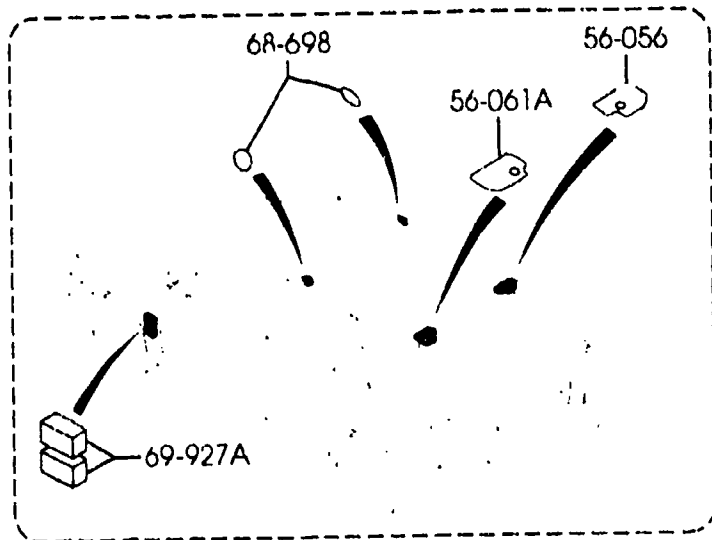

PART NO	QTY	MODEL/RESTRICTION	MODEL/RESTRICTION	MODEL/RESTRICTION	FROM-TO
56-964A B25D-56-398	4	RIVET, SEAL PLATE-SHR OUD	RIVET, PLAQUE ETANCH. HAUB.		
68-698 B25H-56-052	2	COVER, HOLE	COUVERCLE, TROU		
69-927A H360-69-927A	2	INSULATOR, PKG. JUNCT ION	ISOLANT, RACCORD. EMB ALL.		

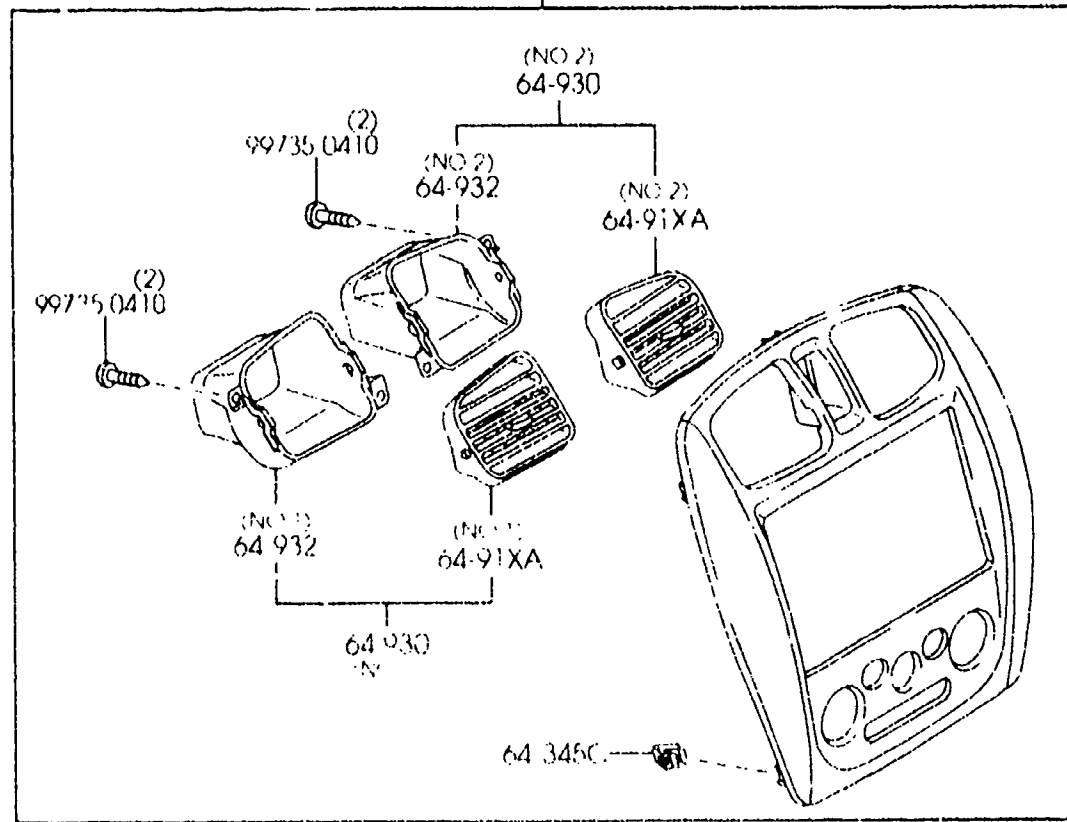
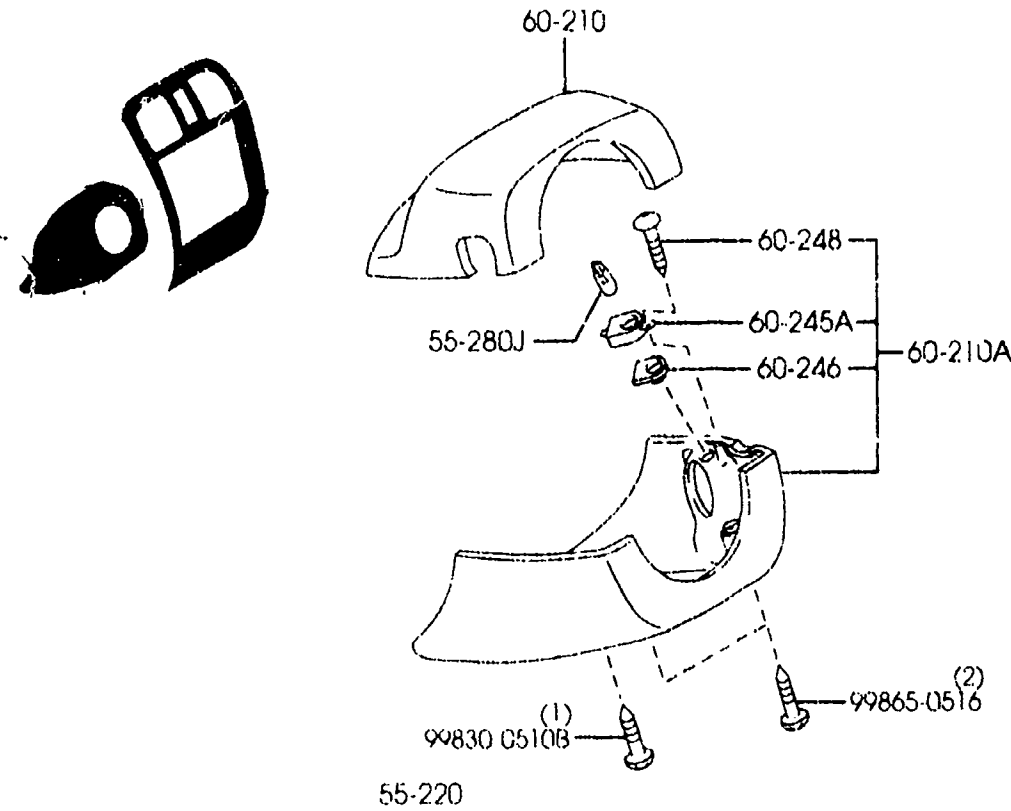

PART NO.	QTY	MODEL/RESTRICTION	MODEL/RESTRICTION	MODEL/RESTRICTION	FROM-TO
55-220		PANEL,CENTER	MONTANT CENTRAL		
BL4C-55-210	1	(STD PANEL) (4DR)	(4PRTS)		
25	INT-	BN3 BEIGE M	BN3 BEIGE METALL.		
61	INT-	BN1 BN2 GRAY METALLIC	BN1 BN2 GRIS METALLIQUE		
BL0M-55-210B	1	(SILVER PANEL) (4DR)	(4PRTS)		
20	INT-	BN4 SILVER METALLIC	BN4 ARGENT METALLIQUE		
BN5V-55-210	1	(SPORTY PANEL) (4DR)	(4PRTS)		
20	INT-	BN4 SILVER METALLIC/OFF-	BN4 ARGENT METALLIQ/NOIR		
BN5V-55-210	1	(5DR)	(5PRTS)		
20	INT-	BN4 SILVER METALLIC/OFF-	BN4 ARGENT METALLIQ/NOIR		
55-280J		BULB	AMPOULE		
B456-60-223	1	14V 1.4W	14V 1.4W		
60-210		COVER,COLUMN-UPPER	GAINE DE DIRECTION, SUP.		
BJ0J-60-221	1				
00	INT-	BN1 BN2 BN4 BLACK	BN1 BN2 BN4 NOIR		
22	INT-	BN3 BROWN	BN3 BRUN		
60-210A		COVER,COLUMN-LOWER	GAINE COLONNE DIRECT ION		
B25D-60-230A	1				
00	INT-	BN1 BN2 BN4 BLACK	BN1 BN2 BN4 NOIR		
22	INT-	BN3 BROWN	BN3 BRUN		
60-245A		CASE,LAMP	BOITIER,FEU		
GE4T-60-245	1				
60-246		LENS,COLUMN COVER	LENTILLE,		
GE4T-60-246	1				
60-248		SCREW,TAPPING	VIS FIXATION SUPPORT		
G030-60-248	2				

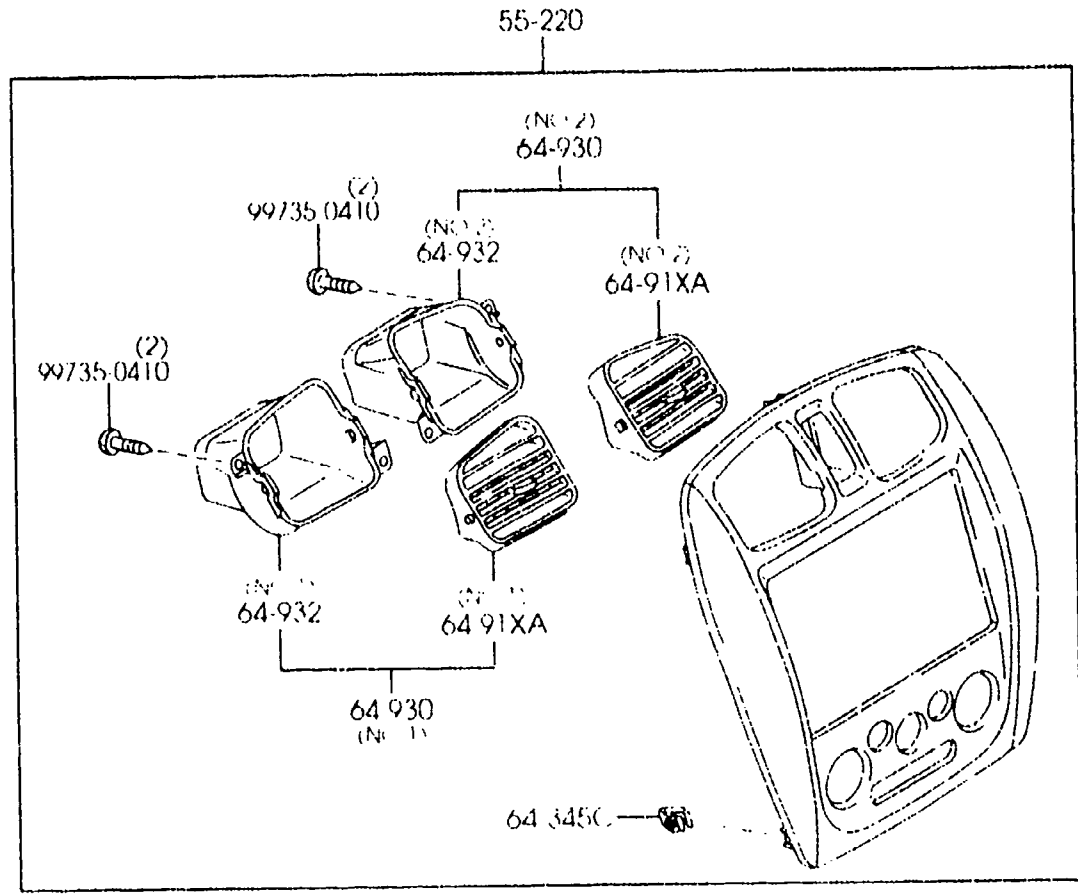
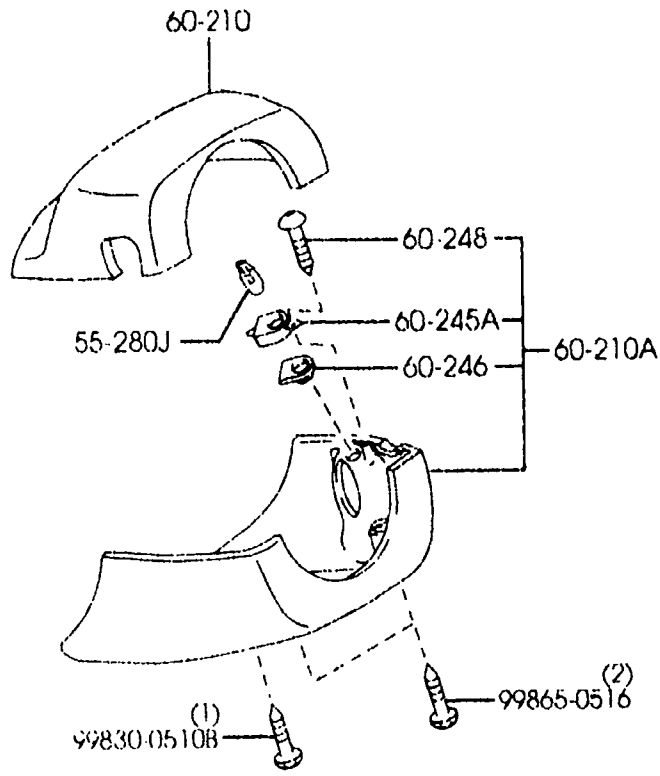

PART NO.	QTY	MODEL/RESTRICTION	MODEL/RESTRICTION	MODEL/RESTRICTION	FROM-TO
64-345C		SPRING, UPPER PLATE	RESSORT, PLAQUE SUP		
S47P-64-345	7				
64-91XA		LOUVER(C), SW. PANEL	PERSIENNE(C), PANN. C		
B25F-64-91XA	1	(ILLUST. NO.1)	OMM.		
22	INT-	BN3 BROWN	BN3 BRUN		
65	INT-	BN1 BN2 BN4 OFF-BLACK	BN1 BN2 BN4 NOIR CLAIR		
B25G-64-91XA	1	(ILLUST. NO.2)			
22	INT-	BN3 BROWN	BN3 BRUN		
65	INT-	BN1 BN2 BN4 OFF-BLACK	BN1 BN2 BN4 NOIR CLAIR		
64-930		GRILLE(C), VENTILATOR	GRILLE(C), VENTILATEUR		
B25F-64-930D	1	(ILLUST. NO.1)			
22	INT-	BN3 BROWN	BN3 BRUN		
65	INT-	BN1 BN2 BN4 OFF-BLACK	BN1 BN2 BN4 NOIR CLAIR		
B25G-64-930D	1	(ILLUST. NO.2)			
22	INT-	BN3 BROWN	BN3 BRUN		
65	INT-	BN1 BN2 BN4 OFF-BLACK	BN1 BN2 BN4 NOIR CLAIR		
64-932		CASE(C), LOUVER	BOITE(C), JALOUSIE		
B25F-64-932C	1	(ILLUST. NO.1)			
B25G-64-932C	1	(ILLUST. NO.2)			

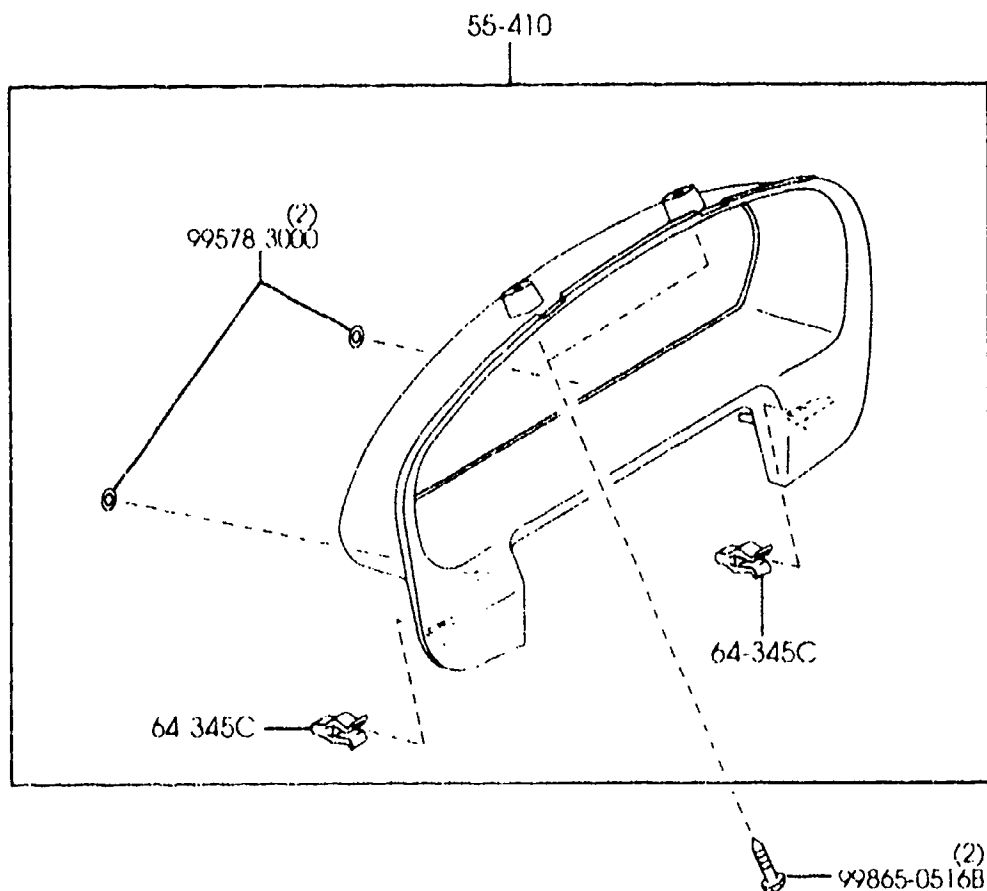

PART NO.	QTY	MODEL/RESTRICTION	MODEL/RESTRICTION	MODEL/RESTRICTION	FROM-TO
55-410		HOOD, METER	VISIÈRE, COMPTEUR		
B25G-55-420A	1				
64-345C		SPRING, UPPER PLATE	RESSORT, PLAQUE SUP		
S47P-64-345	2				



▲ Part number will be assigned.

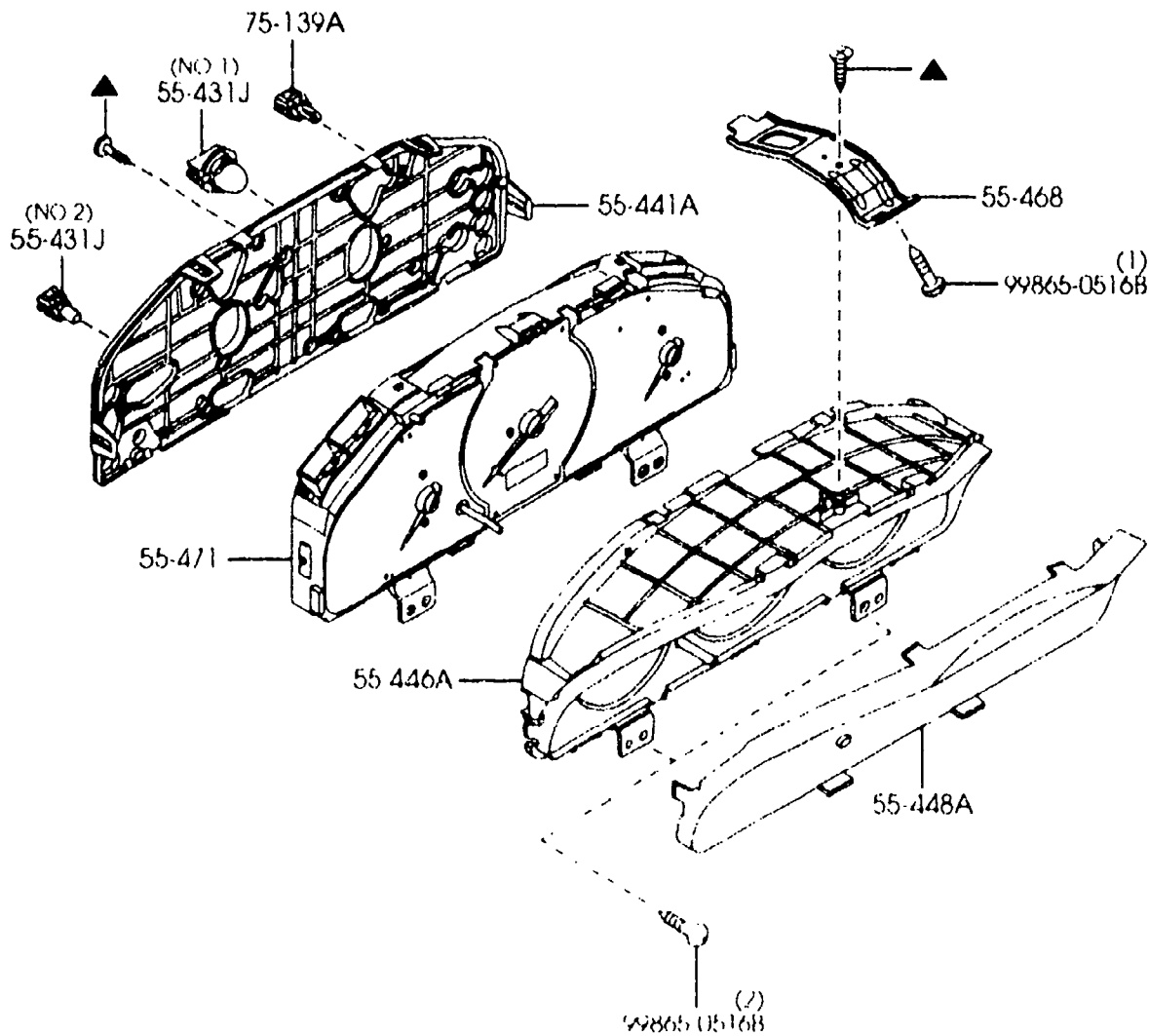

PART NO.	QTY	MODEL/RESTRICTION	MODEL/RESTRICTION	MODEL/RESTRICTION	FROM-TO
55-431J		BULB 'A', METER SET	AMPOULE 'A', GROUPE CO MPT.		
B21M-55-431	2	3.4W (ILLUST. NO.1)	3.4W		
B21N-55-431	1	1.4W (ILLUST. NO.2)	1.4W		
55-441A		CASE, METER	BOITIER COMPTEUR		
B25F-55-441	1				
55-446A		PLATE, WINDOW	PLAQUE, INTERRUPTEUR		
C100-55-446	1				
55-448A		LENS, FRONT	LENTILLE AV		
B25F-55-447	1				
55-468		BRACKET (R), METER SET	SUPPORT (D), GROUPE CO MPT.		
BHOV-55-460	1				
55-471		SPEEDOMETER	COMPTEUR		
BL8D-55-471	1	(KM/MILE)			
BL8E-55-471A	1	(MILE/KM)			
75-139A		BULB	AMPOULE		
BC1D-55-431	11	14V 1.4W (KM/MILE)	14V 1.4W		
BC1D-55-431	12	14V 1.4W (MILE/KM)	14V 1.4W		



▲ Part number will be assigned

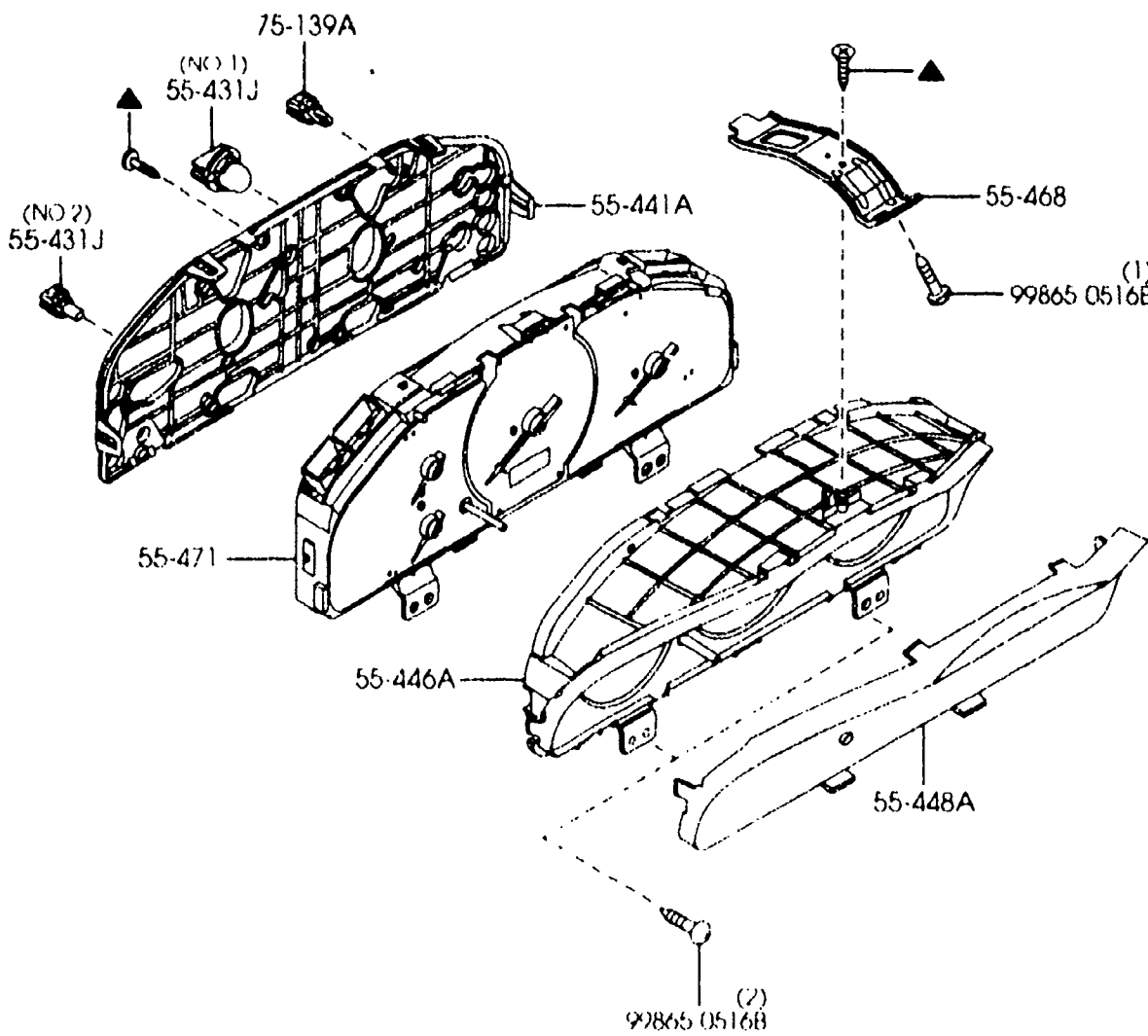

PART NO.	QTY	MODFL/RESTRICTION	MODEL/RESTRICTION	MODEL/RESTRICTION	FROM-TO
55-431J		BULB 'A', METER SET	AMPOULE 'A', GROUPE CO		
B21M-55-431	2	3.4W (ILLUST. NO.1) (STD PANEL)	MPT. 3.4W		
B21N-55-431	2	1.4W (ILLUST. NO.2) (STD PANEL)	1.4W		
D342-55-431	2	(ILLUST. NO.1) (WHITE PANEL)			
D343-55-431	2	(ILLUST. NO.2) (WHITE PANEL)			
55-441A		CASE, METER	BOITIER COMPTEUR		
B25F-55-441	1				
55-446A		PLATE, WINDOW	PLAQUE, INTERRUPTEUR		
C100-55-446	1				
55-448A		LENS, FRONT	LENTILLE AV		
B25F-55-447	1				
55-468		BRACKET (R), METER SET	SUPPORT (D), GROUPE CO		
BH0V-55-468	1		MPT.		
55-471		SPEEDOMETER	COMPTEUR		
BL8F-55-471	1	(STD PANEL+KM/MILE+W /O KEY LESS ENTRY)			
BL8G-55-471	1	(STD PANEL+KM/MILE+W /KEY LESS ENTRY)			
BL8H-55-471A	1	(STD PANEL+MILE/KM+W /O KEY LESS ENTRY)			
BL8J-55-471A	1	(STD PANEL+MILE/KM+W /KEY LESS ENTRY)			
BL8M-55-471	1	(WHITE PANEL+KM/MILE )			
BN5W-55-471	1	(WHITE PANEL+MILE/KM )			
75-139A		BULB	AMPOULE		
BC1D-55-431	11	14V 1.4W (MILE/KM)	14V 1.4W		
BC1D-55-431	12	14V 1.4W (KM/MILE)	14V 1.4W		



▲ Part number will be assigned

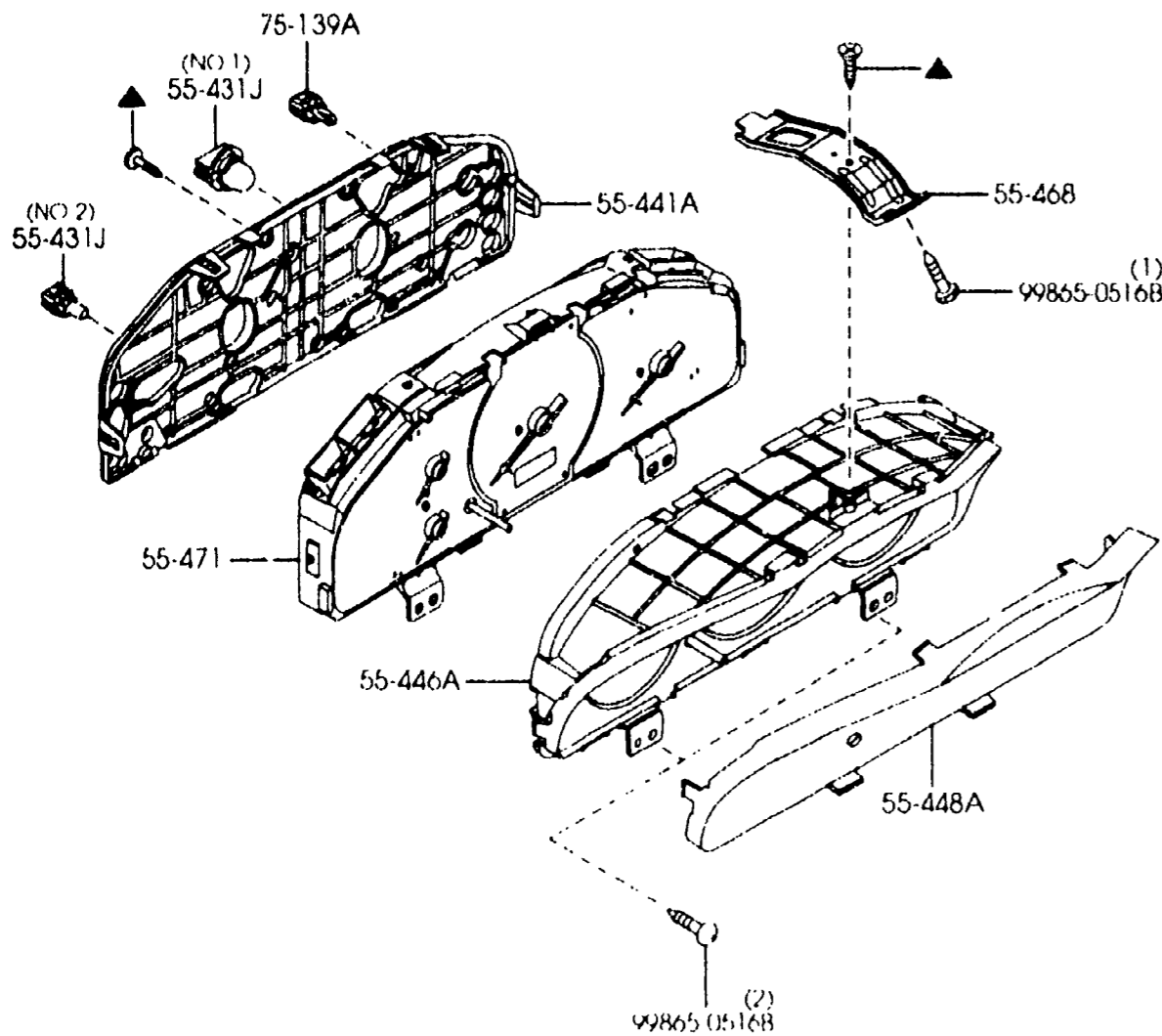

PART NO	QTY	MODEL/RESTRICTION	MODEL/RESTRICTION	MODEL/RESTRICTION	FROM-TO
55-431J		BULB 'A', METER SET	AMPOULE 'A', GROUPE CO		
D342-55-431	1	(ILLUST. NO.1)	MPT.		
D343-55-431	2	(ILLUST. NO.2)			
55-441A		CASE, METER	BOITIER COMPTEUR		
B25F-55-441	1				
55-446A		PLATE, WINDOW	PLAQUE, INTERRUPTEUR		
C100-55-446	1				
55-448A		LENS, FRONT	LENTILLE AV		
B25F-55-447	1				
55-468		BRACKET (R), METER SET	SUPPORT (D), GROUPE CO		
BHOV-55-468	1		MPT.		
55-471		SPEEDOMETER	COMPTEUR		
*BL8M-55-471	1	(W/O ROOF RAIL)	(SANS GALERIE)		
BN5W-55-471	1	(W/ROOF RAIL)	(AVEC GALERIE)		
75-139A		BULB	AMPOULE		
BC1D-55-431	11	14V 1.4W (W/ROOF RAIL)	14V 1.4W (AVEC GALERIE)		
*BC1D-55-431	12	14V 1.4W (W/O ROOF RAIL)	14V 1.4W (SANS GALERIE)		



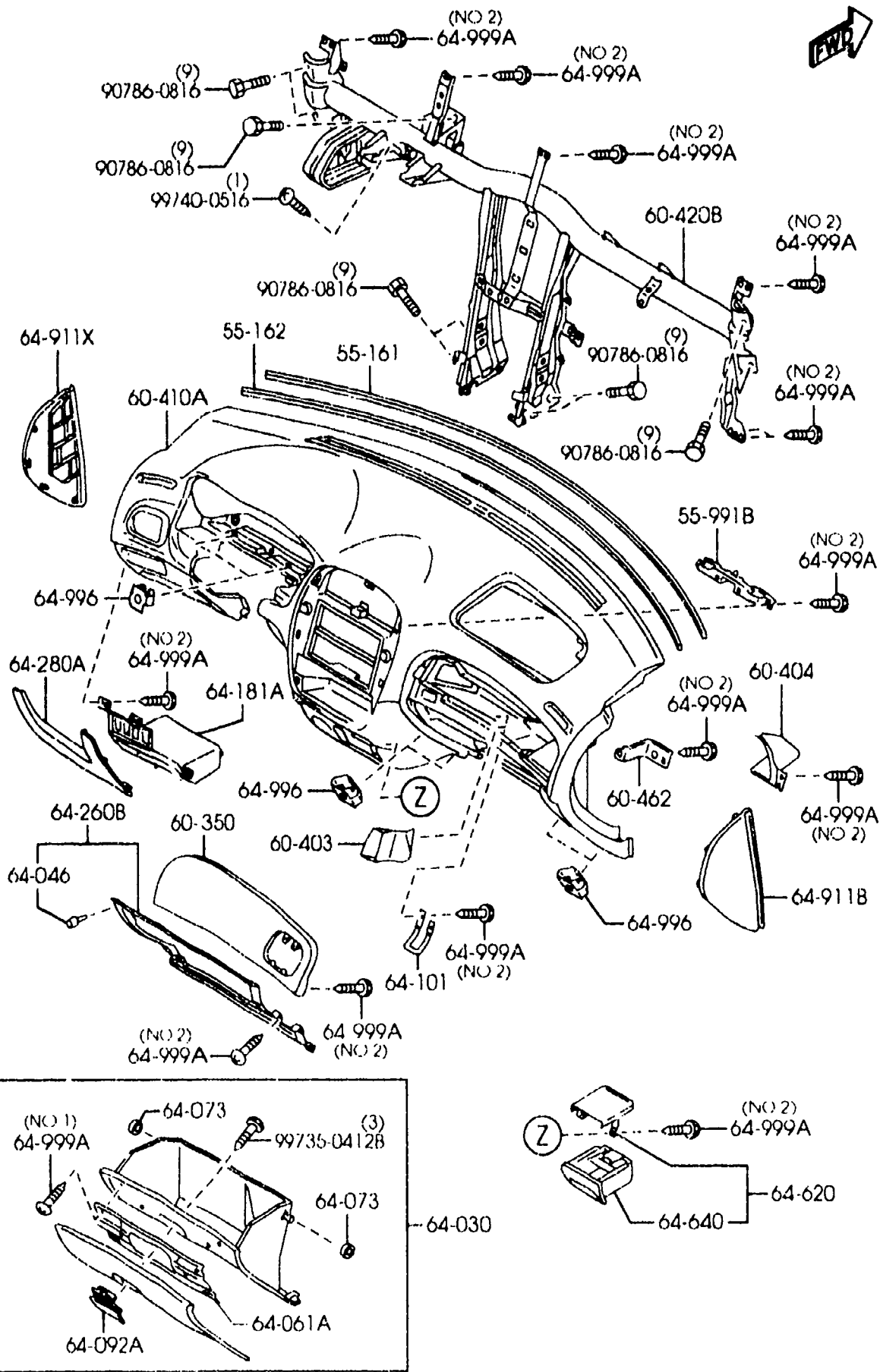

PART NO	QTY	MODEL/RESTRICTION	MODEL/RESTRICTION	MODEL/RESTRICTION	FROM-TO
55-161		TAPE, SEAL	RUBAN D'ETANCHEITE		-1101
GE4T-55-161	1				1101-
BL4C-55-161	1				
55-162		TAPE, SEAL	RUBAN D'ETANCHEITE		-1101
GE6R-55-161	1				1101-
B30D-55-162	1				
55-991B		BRACKET NO. 1	SUPPORT NO. 1		
B25D-55-991A	1				
60-350		PAD, CRASH	TABLEAU DE BORD		
BJ0J-60-360	1				
22	INT-	BN3 BROWN	BN3 BRUN		
65	INT-	BN1 BN2 BN4 OFF-BLACK	BN1 BN2 BN4 NOIR CLAIR		
60-403		COLLAR, INST. PANEL	COLLIER, TABLEAU BORD		
BJ0J-60-403	1				
60-404		COLLAR, INST. PANEL	COLLIER, TABLEAU BORD		
BJ0J-60-404A	1				
60-410A		PANEL, INSTRUMENT	TABLEAU DE BORD		-1511
BJ0J-60-401B C (BJ0J-60-401C)	1				
65	INT-	BN4 OFF-BLACK	BN4 NOIR CLAIR		
67	INT-	BN1 BN2 OFF-BLACK/GRAY	BN1 BN2 NOIR CLAIR/GRIS		
82	INT-	BN3 BROWN/BEIGE	BN3 BRUN/BEIGE		
*BJ0J-60-401C	1				1511-
* 65	INT-	BN4 OFF-BLACK	BN4 NOIR CLAIR		
* 67	INT-	BN1 BN2 OFF-BLACK/GRAY	BN1 BN2 NOIR CLAIR/GRIS		
* 82	INT-	BN3 BROWN/BEIGE	BN3 BRUN/BEIGE		
60-420B		MEMBER, CRASH PAD	MEMBRE, TABLEAU BORD		-1305
BL8D-60-420 A (BL8D-60-420A)	1				1305-
BL8D-60-420A	1				
BJ0J-60-401B		1101 BJ22*	-419568		
C BJ0J-60-401C		1305 BJ22*	-441930		
W201-64-999	2	1511 BJ22*	-470477		

AUBA09

(2B59120)

CAT. AUBA09-02

2001-07

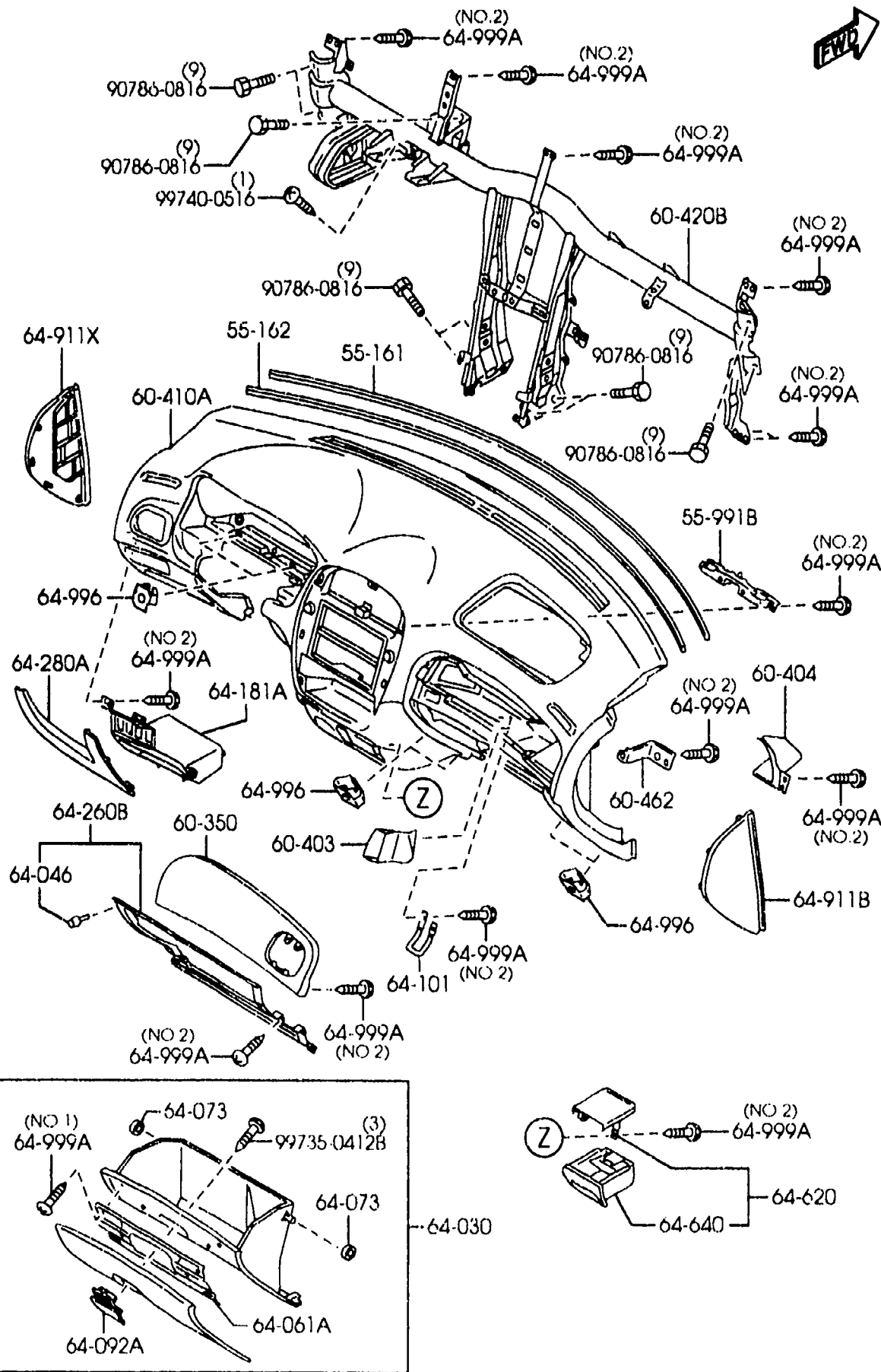

PART NO	QTY	MODEL/RESTRICTION	MODEL/RESTRICTION	MODEL/RESTRICTION	FROM-TO
60-462		BRACKET, INST. PANEL	SUPPORT, TAB.-BORD		
BJ0J-60-465	1				
64-030		BOX, GLOVE	COUVERCLE, BOITE A GANTS		
BL8D-64-030A	1				
05	INT-	BN1 BN2 GRAY	BN1 BN2 GRIS		
65	INT-	BN4 OFF-BLACK	BN4 NOIR CLAIR		
80	INT-	BN3 BEIGE	BN3 BEIGE		
64-046		CUSHION, RUBBER-GLOVE LID	COUSSIN, CAOUT.-COUV. BOIT		
LBB2-64-046	3				
64-061A		REINF., GLOVE	RENFORT, BOITE A GANTS		
BJ0E-64-061	1				
64-073		RUBBER, STOPPER-GLOVE LID	COMME, BUTOIR		
BJ0E-64-073	2				
64-092A		LOCK, GLOVE LID	SERRURE,		
GE4T-64-090F	1				
05	INT-	BN1 BN2 GRAY	BN1 BN2 GRIS		
65	INT-	BN4 OFF-BLACK	BN4 NOIR CLAIR		
80	INT-	BN3 BEIGE	BN3 BEIGE		
64-101		STRIKER	GACHE		
LBB2-64-101	1				
64-181A		COVER, POCKET	COUVERCLE POCLETTE		
BJ0J-64-181	1				
64-260B		PANEL, LOWER	PANNEAU INF.		
BJ0J-64-260A	1				
64-280A		PANEL, LOWER	PANNEAU INFERIEUR		
BJ0J-64-280	1				
05	INT-	BN1 BN2 GRAY	BN1 BN2 GRIS		
65	INT-	BN4 OFF-BLACK	BN4 NOIR CLAIR		
80	INT-	BN3 BEIGE	BN3 BEIGE		

AUBA09

(2B59120)

CAT. AUBA09-02

2001-07



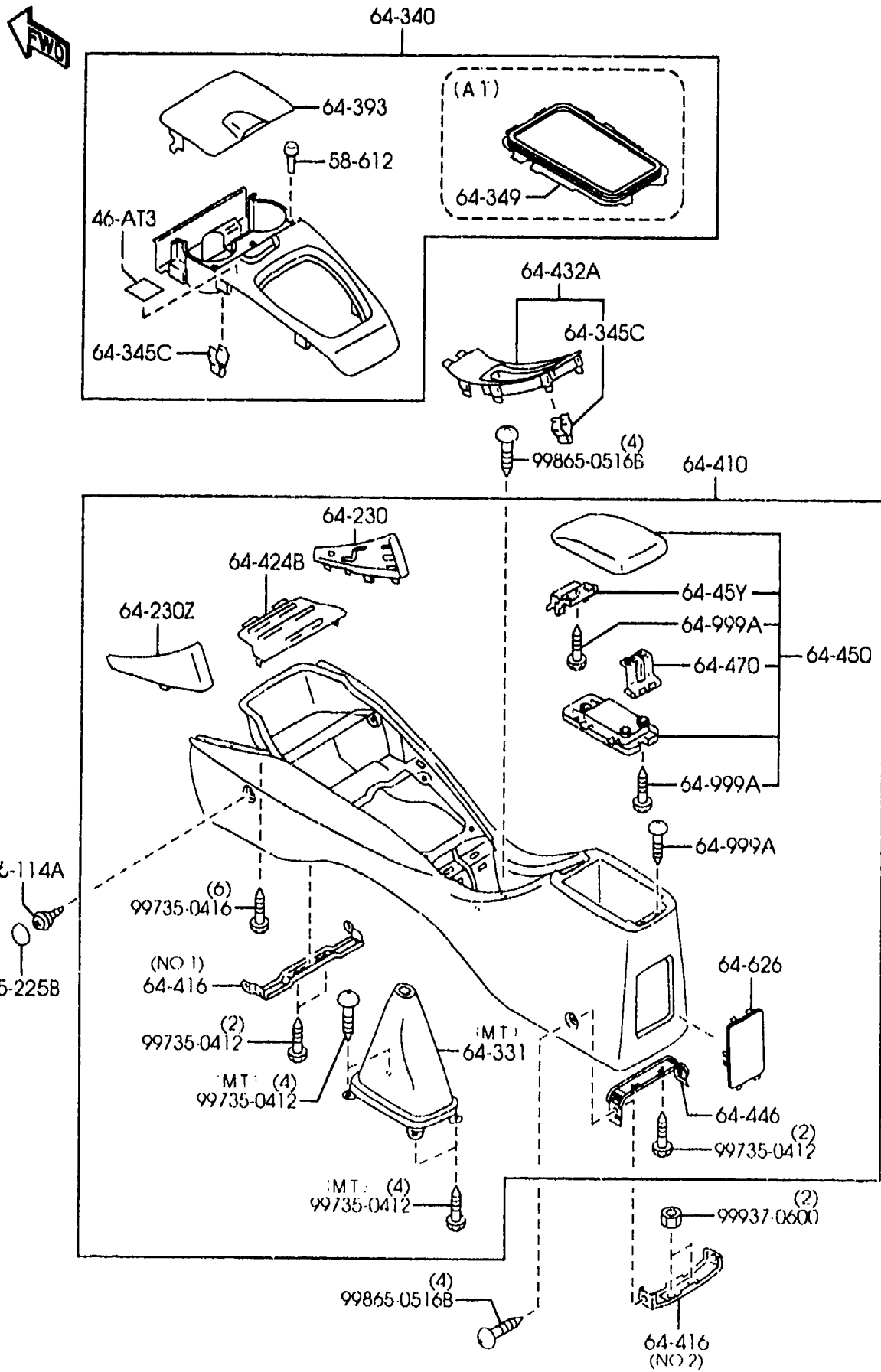

PART NO.	QTY	MODEL/RESTRICTION	MODEL/RESTRICTION	MODEL/RESTRICTION	FROM-TO
46-AT3		LABEL, CHANGE	ETIQUETTE, CHANGE.		
N002-46-AT3	1	((MT))>(4DR)>(MPS SUS P)	((B.V.MANU))>(4PRTS)>(SUSP.MPS)		-1416
B33M-46-AT3	1	((MT))>(4DR)>(MPS SUS P)	((B.V.MANU))>(4PRTS)>(SUSP.MPS)		1416-
55-114A		SCREW, TAPPING	VIS, PIQUAGE-PANNEAU LAT.		
GG5H-55-112	2				
05	INT-	BN1 BN2 GRAY	BN1 BN2 GRIS		
55-225B		COVER, HOLE	COUVERCLE		
GG5H-55-225	2				
05	INT-	BN1 BN2 GRAY	BN1 BN2 GRIS		
65	INT-	BN4 OFF-BLACK	BN4 NOIR CLAIR		
80	INT-	BN3 BEIGE	BN3 BEIGE		
58-612		CUSHION, RUBBER	CAOUTCHOUC		
B092-64-046	3				
64-230		WALL(R), SIDE	FLANC(D)		
B30D-64-231A	1				
05	INT-	BN1 BN2 GRAY	BN1 BN2 GRIS		
65	INT-	BN4 OFF-BLACK	BN4 NOIR CLAIR		
80	INT-	BN3 BEIGE	BN3 BEIGE		
64-230Z		WALL(L), SIDE	FLANC(G)		
B30D-64-241A	1				
05	INT-	BN1 BN2 GRAY	BN1 BN2 GRIS		
65	INT-	BN4 OFF-BLACK	BN4 NOIR CLAIR		
80	INT-	BN3 BEIGE	BN3 BEIGE		
64-331		BOOT, CHANGE	COIFFE, LEVIER DE VI TESSE (B.V.MANU)		
GG2M-64-330	1	(MT)			
00	INT-	BN1 BN2 BN4 BLACK	BN1 BN2 BN4 NOIR		
22	INT-	BN3 BEIGE	BN3 BEIGE		
64-340		PLATE, UPPER	PLAQUETTE, SUP.		
B30D-64-340A	1	((M ))>(4DR)>(SPORT S USF)	((B.V.MANU))>(4PRTS)>(SUSP. SPORTIVE)		

1416 BJ22\* -460681

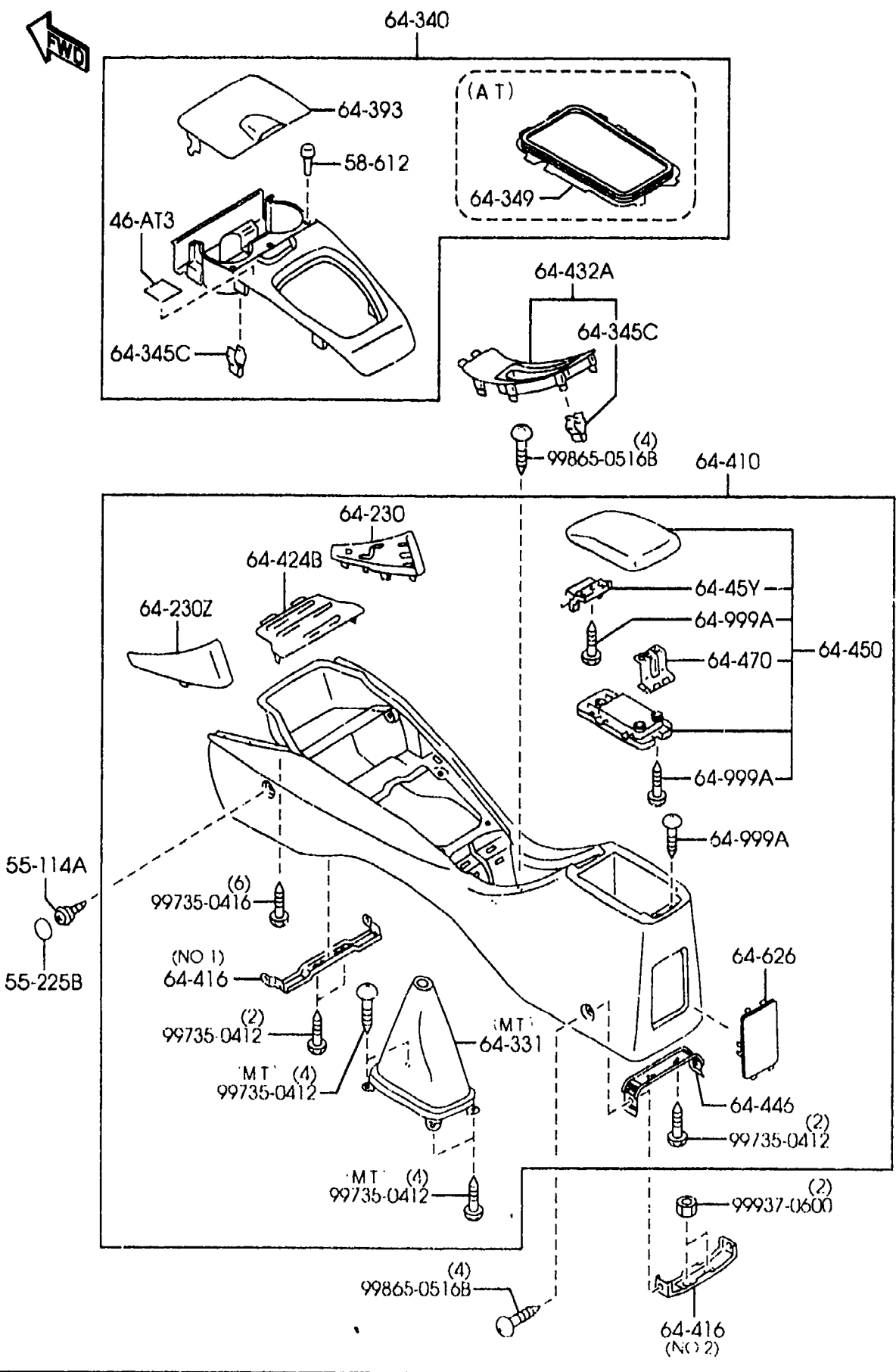

PART NO.	QTY	MODEL/RESTRICTION	MODEL/RESTRICTION	MODEL/RESTRICTION	FROM-TO
CONT'D					
00	INT-	BN1 BN2 BN4 BLACK	BN1 BN2 BN4 NOIR		
22	INT-	BN3 BEIGE	BN3 BEIGE		
B30E-64-340A	1	((AT))>(4DR)	((B.V.AUTOM))>(4PRTS)		
00	INT-	BN1 BN2 BN4 BLACK	BN1 BN2 BN4 NOIR		
22	INT-	BN3 BEIGE	BN3 BEIGE		
B31A-64-340A	1	((MT))>(5DR)	((B.V.MANU))>(5PRTS)		
20	INT-	BN4 SILVER METALLIC	BN4 ARGENT METALLIQUE		
B31B-64-340A	1	((AT))>(5DR)	((B.V.AUTOM))>(5PRTS)		
20	INT-	BN4 SILVER METALLIC	BN4 ARGENT METALLIQUE		
BN7H-64-340	1	((MT))>(4DR)>(MPS SUS P)	((B.V.MANU))>(4PRTS)>(SUSP.MPS)		-1416
20	INT-	BN4 SILVER METALLIC	BN4 ARGENT METALLIQUE		
BN7H-64-340A	1	((MT))>(4DR)>(MPS SUS P)	((B.V.MANU))>(4PRTS)>(SUSP.MPS)		1416-
20	INT-	BN4 SILVER METALLIC	BN4 ARGENT METALLIQUE		
		64-345C	SPRING, UPPER PLATE	RESSORT, PLAQUE SUP	
B30D-64-345	10				
		64-349	RING, BOOTS PANEL	BAGUE, PANN. COFFRE BA GAGE	
*GG2P-64-332A	1	(AT)		(B.V.AUTOM)	
		64-393	COVER	COUVERCLE	
B30D-64-393A	1	((MT))>(4DR)>(SPORT S USP)	((B.V.MANU))>(4PRTS)>(SUSP. SPORTIVE)	((B.V.AUTOM))>(4PRTS)	
00	INT-	BN1 BN2 BN4 GRAY	BN1 BN2 BN4 GRIS		
22	INT-	BN3 BEIGE	BN3 BEIGE		
B31A-64-393A	1	((MT))>(4DR)>(MPS SUS P)	((B.V.MANU))>(4PRTS)>(SUSP.MPS)	((B.V.MANU))>(5PRTS)	
		((MT))>(5DR)		((B.V.AUTOM))>(5PRTS)	
		((AT))>(5DR)		((B.V.AUTOM))>(5PRTS)	
20	INT-	BN4 SILVER METALLIC	BN4 ARGENT METALLIQUE		
1416 BJ22* -460681					

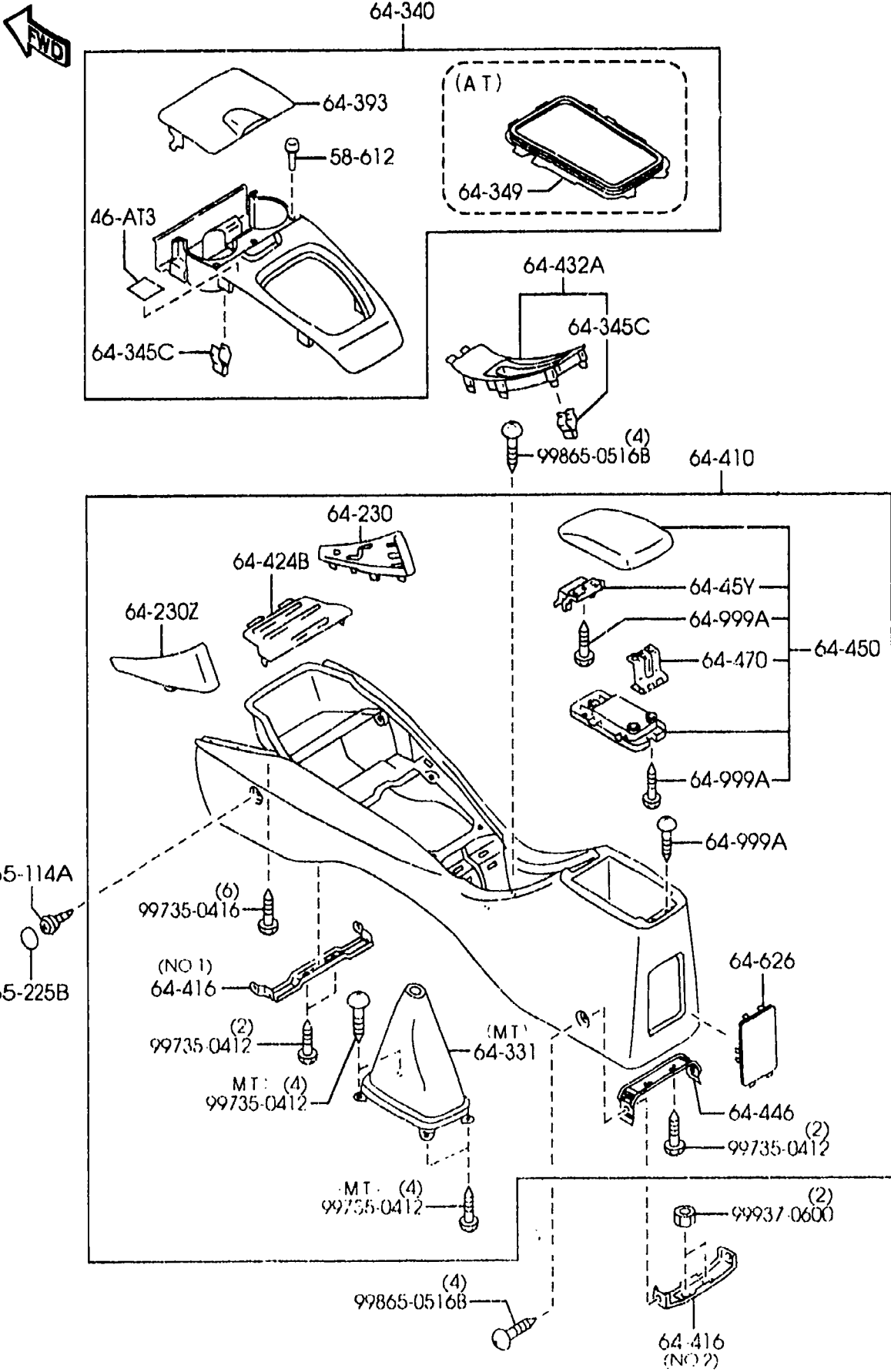

PART NO.	QTY	MODEL/RESTRICTION	MODEL/RESTRICTION	MODEL/RESTRICTION	FROM-TO
64-410		CONSOLE, REAR	CONSOLE, AR		
B30D-64-420B	1	(MT)	(B.V.MANU)		
05	INT-	BN1 BN2 GRAY/BLACK	BN1 BN2 GRIS-NOIR		
65	INT-	BN4 OFF-BLACK/BLACK	BN4 NOIR CLAIR/NOIR		
80	INT-	BN3 BEIGE/BROWN	BN3 BEIGE/BRUN		
B30E-64-420B	1	(AT)	(B.V.AUTOM)		
05	INT-	BN1 BN2 GRAY	BN1 BN2 GRIS		
65	INT-	BN4 OFF-BLACK	BN4 NOIR CLAIR		
80	INT-	BN3 BEIGE	BN3 BEIGE		
64-416		BRACKET, CONSOLE-NO. 3	SUPPORT		
B30D-64-416	1	(ILLUST. NO. 1)			
GE4T-64-436	1	(ILLUST. NO. 2)			
64-424B		COVER, REAR CONSOLE	COUVERCLE CONSOLE AR RIERE		
B30D-64-424	1				
05	INT-	BN1 BN2 GRAY	BN1 BN2 GRIS		
65	INT-	BN4 OFF-BLACK	BN4 NOIR CLAIR		
80	INT-	BN3 BEIGE	BN3 BEIGE		
64-432A		BOOT, RR CONSOLE	SOUFFLET, CONSOLE AR		
B30D-64-43YB	1				
05	INT-	BN1 BN2 GRAY	BN1 BN2 GRIS		
65	INT-	BN4 OFF-BLACK	BN4 NOIR CLAIR		
80	INT-	BN3 BEIGE	BN3 BEIGE		
64-446		BRACKET, REAR CONSOLE	SUPPORT, CONSOLE AR.		1110-
B28V-64-446	1				
64-45Y		LOCK, CONSOLE LID	VERROUILLAGE, COUV. C ONSOL		
BC1G-64-45YA	1				
64-450		LID, CONSOLE	COUVERCLE CONSOLE		
BJ0J-64-450B	1				
05	INT-	BN1 BN2 GRAY	BN1 BN2 GRIS		
65	INT-	BN4 OFF-BLACK	BN4 NOIR CLAIR		
80	INT-	BN3 BEIGE	BN3 BEIGE		
1110 BJ22* -420731					

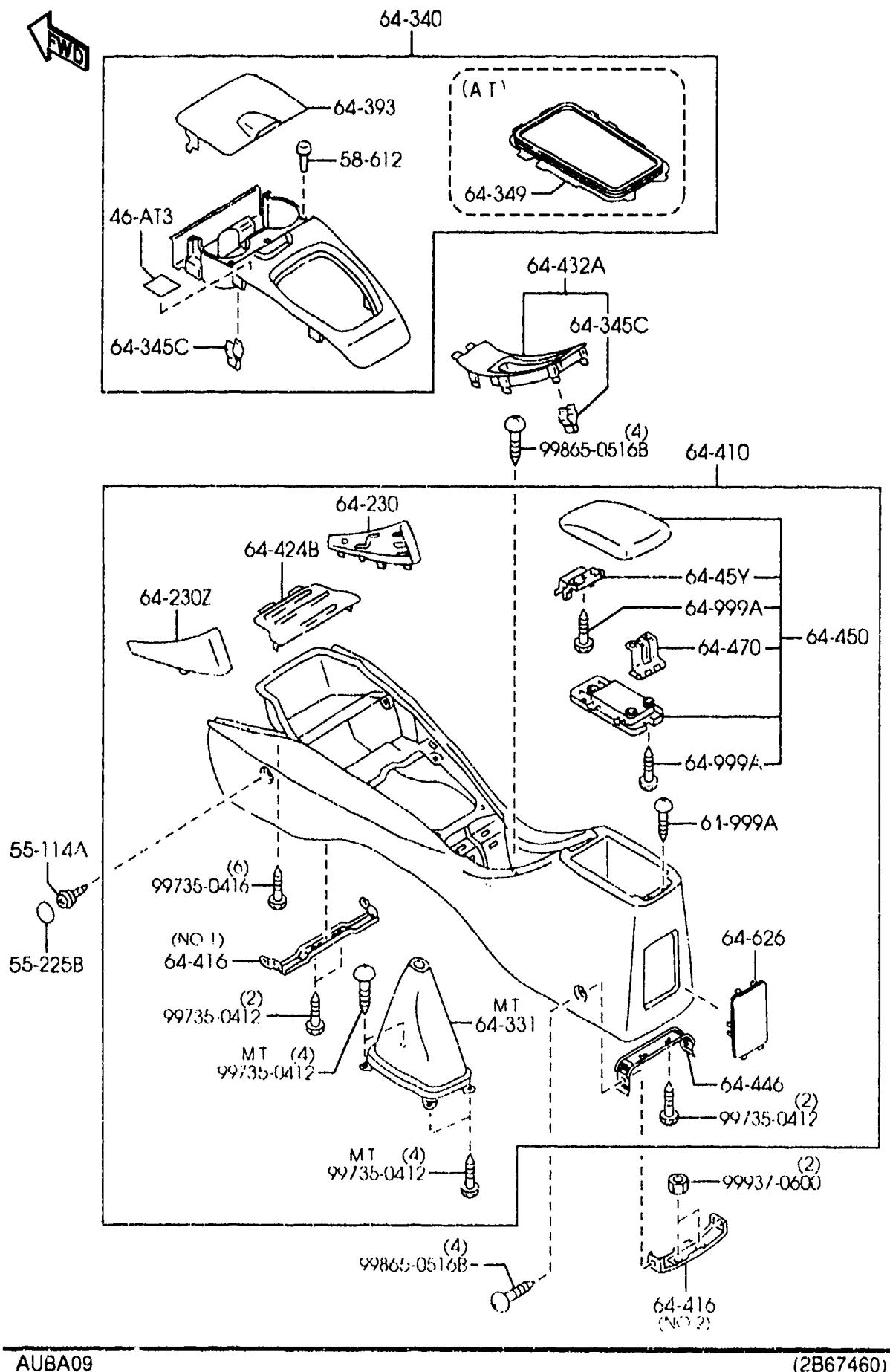

PART NO.	QTY	MODEL/RESTRICTION	MODEL/RESTRICTION	MODEL/RESTRICTION	FROM-TO
64-470		HINGE	CHARNIERE		
BJ0J-64-45X	1				
64-626		COVER	CACHE		
GC5D-64-626A	1				
05	INT-	BN1 BN2 GRAY	BN1 BN2 GRIS		
65	INT-	BN4 OFF-BLACK	BN4 NOIR CLAIR		
80	INT-	BN3 BEIGE	BN3 BEIGE		
64-999A		SCREW, TAPPING	VIS TARAUSEUSE		
P100-64-999	5				

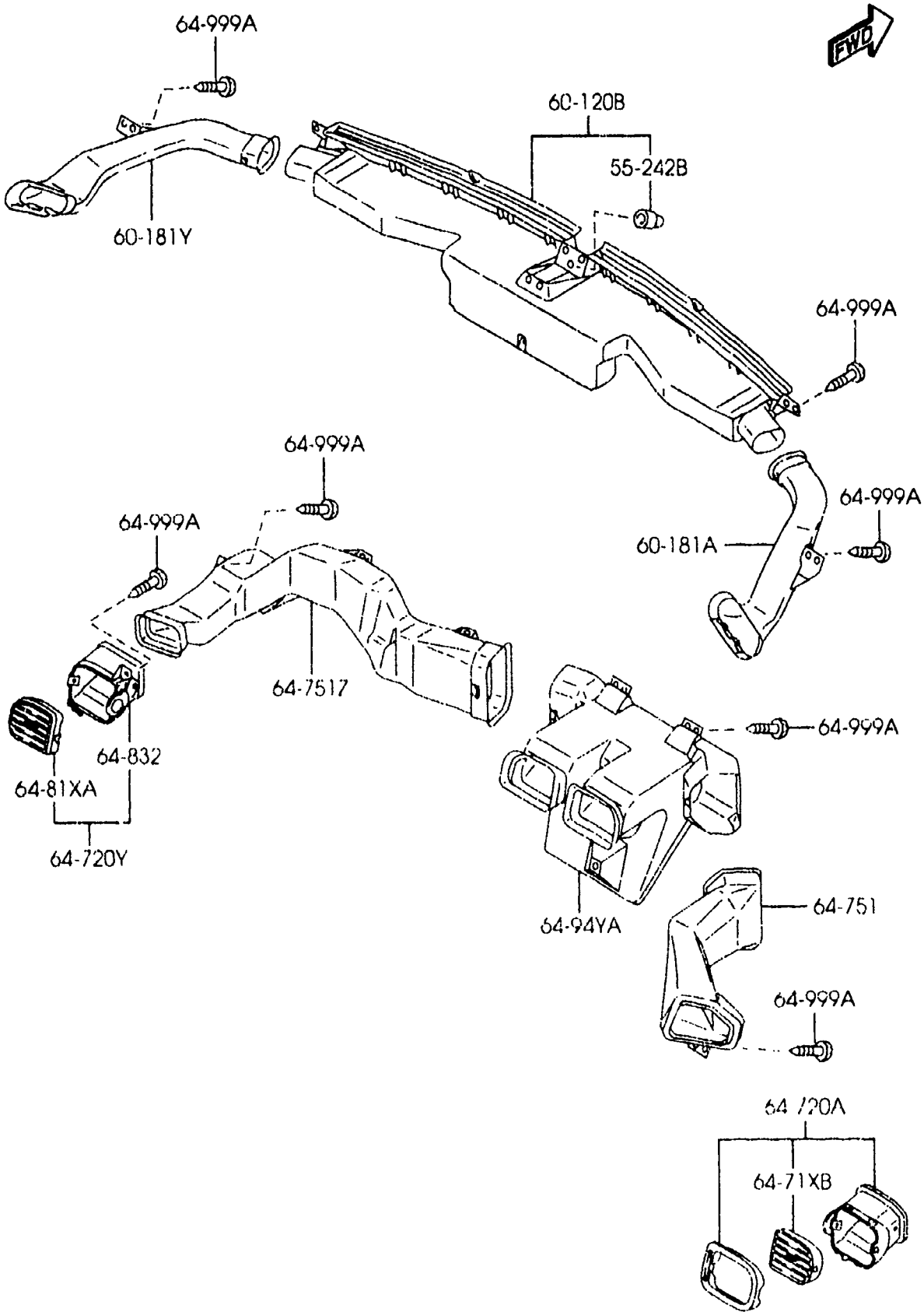

PART NO.	QTY	MODEL./RESTRICTION	MODEL./RESTRICTION	MODEL./RESTRICTION	FROM-TO
55-242B GE4T-55-242	3	RUBBER, RADIO BOX	CAOUTCHOUC, BOITE RADIO		
60-120B BJ0J-60-120	1	NOZZLE, DEFROSTER	INJECTEUR DEGIVRAGE		
60-181A BJ0J-60-181	1	DUCT(R), SIDE DEMIST.	CONDUITE(G), DESEMBUA		
60-181Y BJ0J-60-191	1	DUCT(L), SIDE DEMIST.	CONDUITE(G),		
64-71XB B25G-64-71X	1	LOUVER(R), VENT. GRILL E	PERSIENNE(D), GRILLE VENT.		
22	INT-	BN3 BROWN	BN3 BRUN		
65	INT-	BN1 BN2 BN4 OFF-BLACK	BN1 BN2 BN4 NOIR CLAIR		
64-720A BJ0J-64-730	1	GRILLE(R), VENTILATOR	GRILLE(D), AERATEUR		
22	INT-	BN3 BROWN	BN3 BRUN		
65	INT-	BN1 BN2 BN4 OFF-BLACK	BN1 BN2 BN4 NOIR CLAIR		
64-720Y BJ0J-64-830A	1	GRILLE(L), VENTILATOR	GRILLE(G), AERATEUR		
22	INT-	BN3 BROWN	BN3 BRUN		
65	INT-	BN1 BN2 BN4 OFF-BLACK	BN1 BN2 BN4 NOIR CLAIR		
64-751 BJ0J-64-74X	1	DUCT(R)	CONDUIT (D)		
64-751Z BJ0J-64-841A	1	DUCT(L)	CONDUIT (G)		
64-81XA B25G-64-81X	1	LOUVER(L), VENT. GRILL E	PERSIENNE(G), GRILLE VENT.		
22	INT-	BN3 BROWN	BN3 BRUN		
65	INT-	BN1 BN2 BN4 OFF-BLACK	BN1 BN2 BN4 NOIR CLAIR		



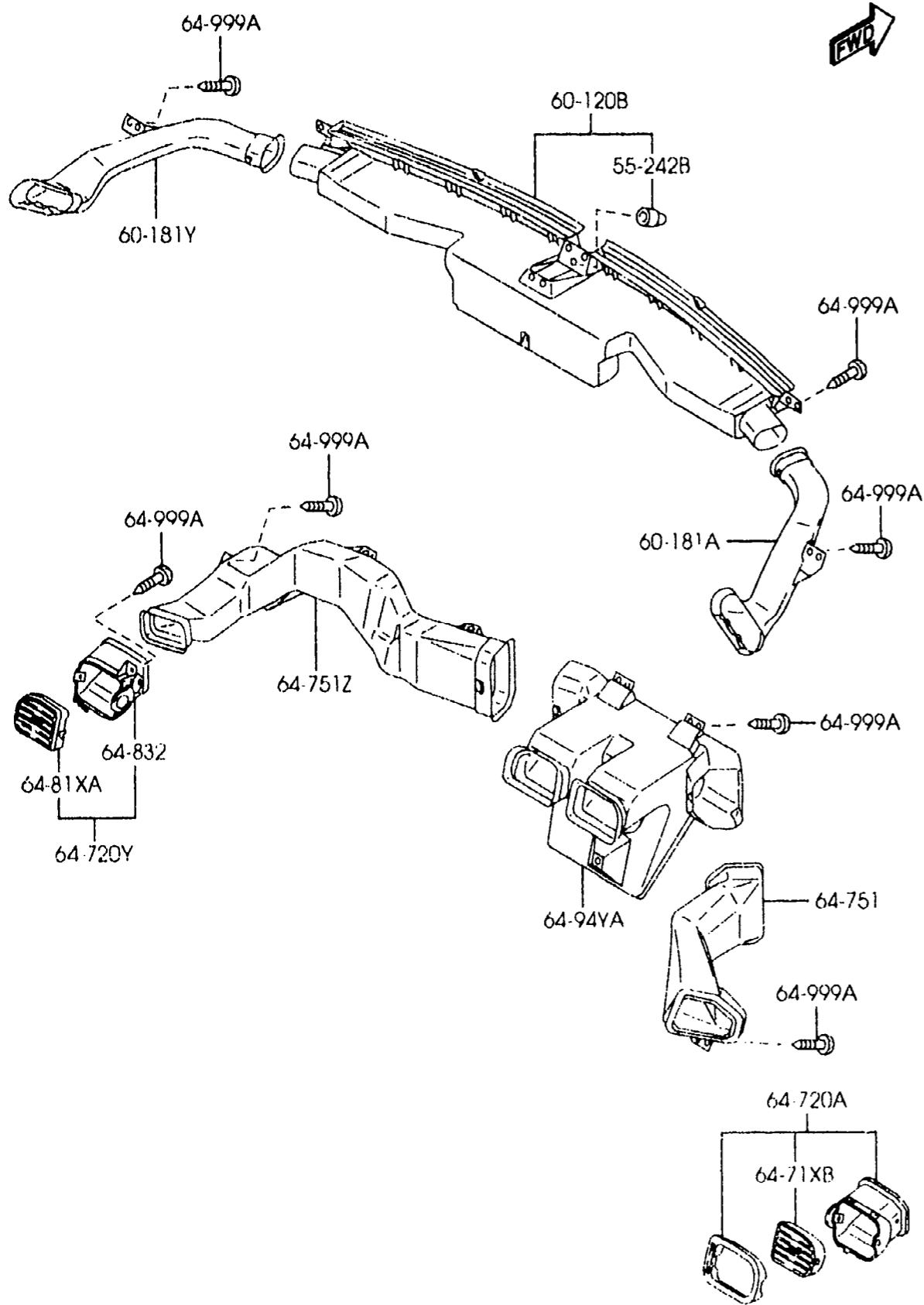

PART NO.	QTY	MODEL/RESTRICTION	MODEL/RESTRICTION	MODEL/RESTRICTION	FROM-TO
64-832		CASE(L), LOUVER	BOITE(G), JALOUSIE		
BJ0J-64-832A	1				
22	INT-	BN3 BROWN	BN3 BRUN		
65	INT-	BN1 BN2 BN4 OFF-BLACK	BN1 BN2 BN4 NOIR CLAIR		
64-94YA		DUCT, CENTER	CONDUIT		
BJ0J-64-94Y	1				
64-999A		SCREW, TAPPING	VIS TARAUSEUSE		
W201-64-999	16				



(DRIVER SIDE)  
(STD TYPE)  
(STG TYPE)

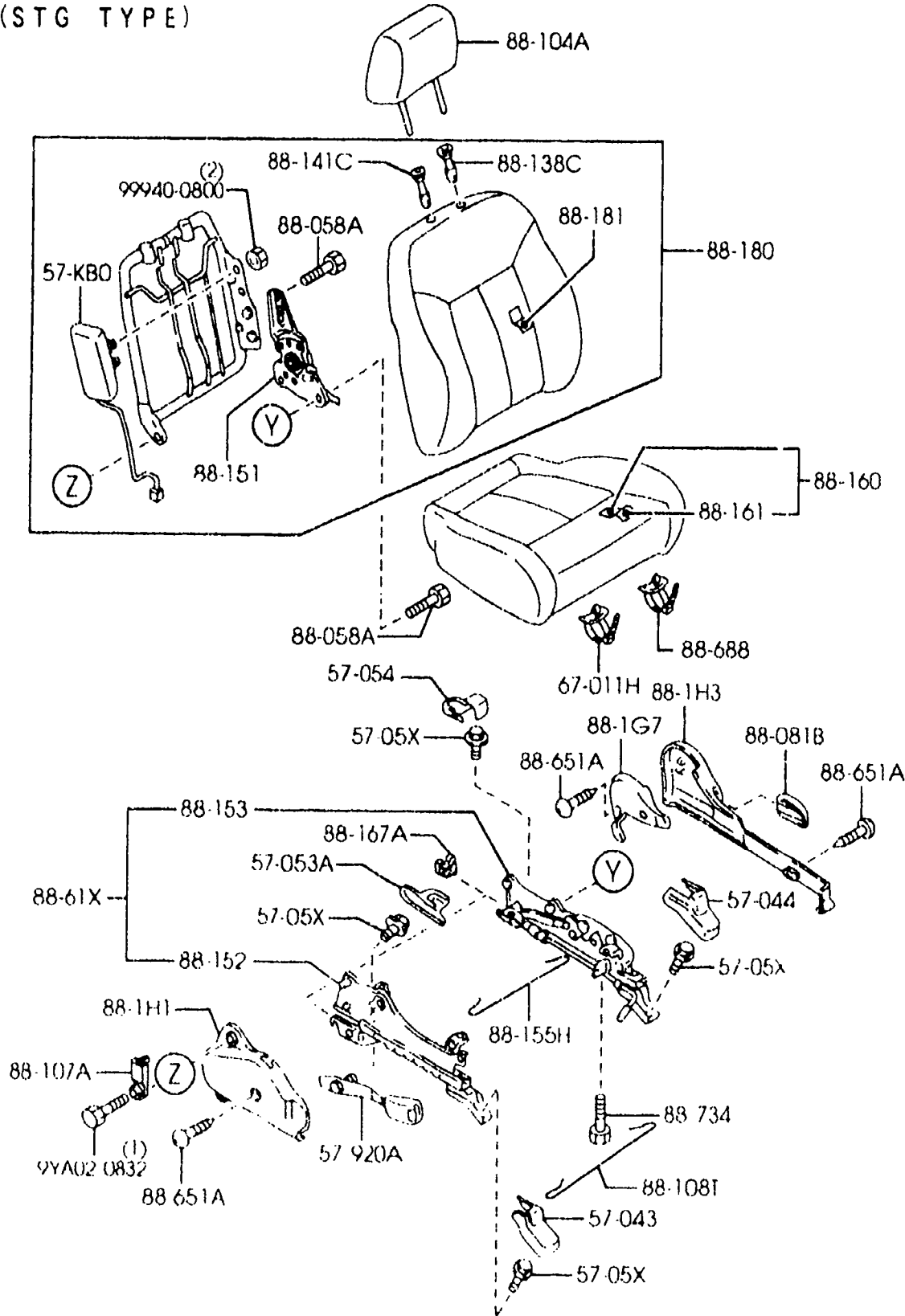

(DRIVER SIDE)  
(STB TYPE)  
(STC TYPE)  
(STE TYPE)

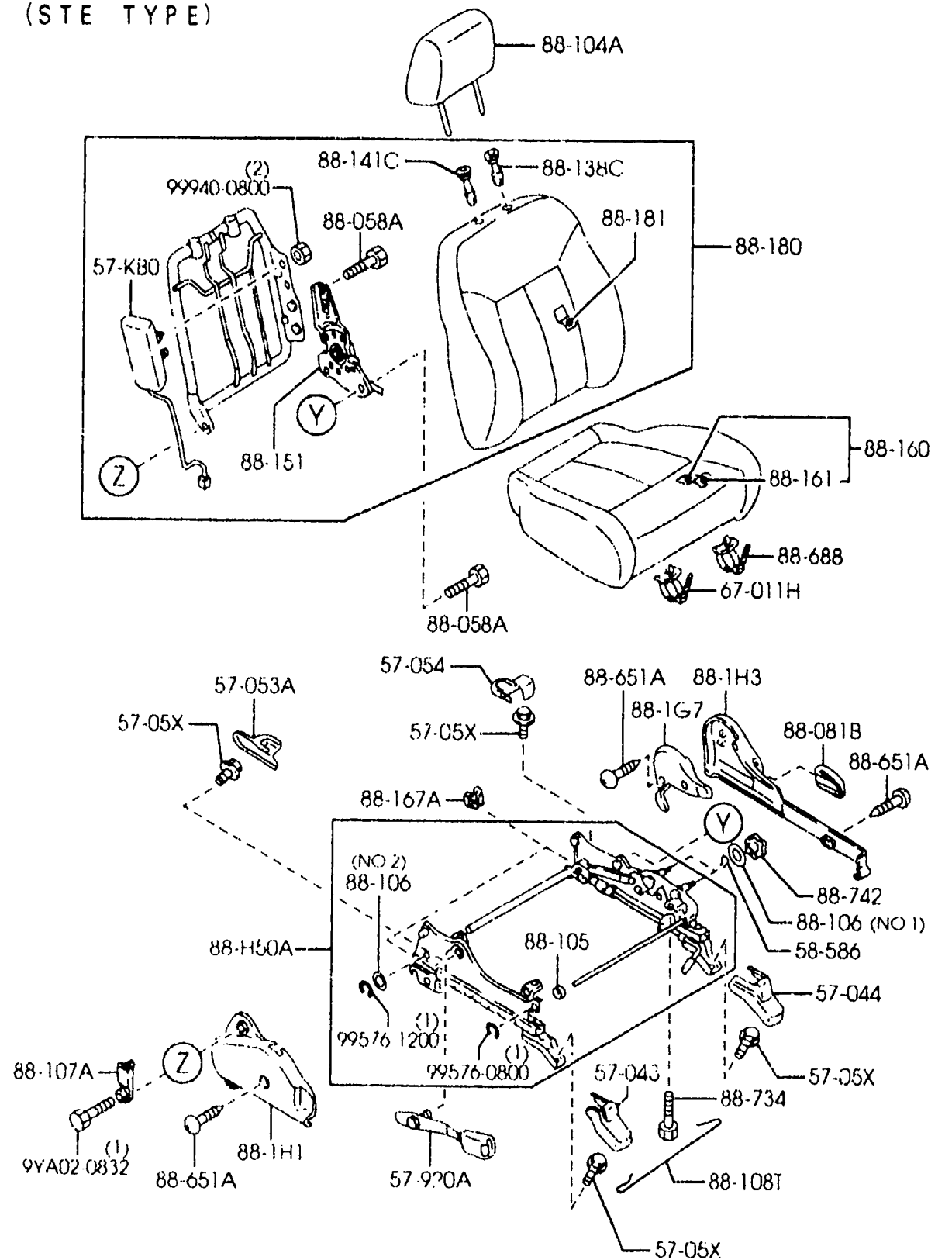



(DRIVER SIDE)  
(STA TYPE)  
(STF TYPE)

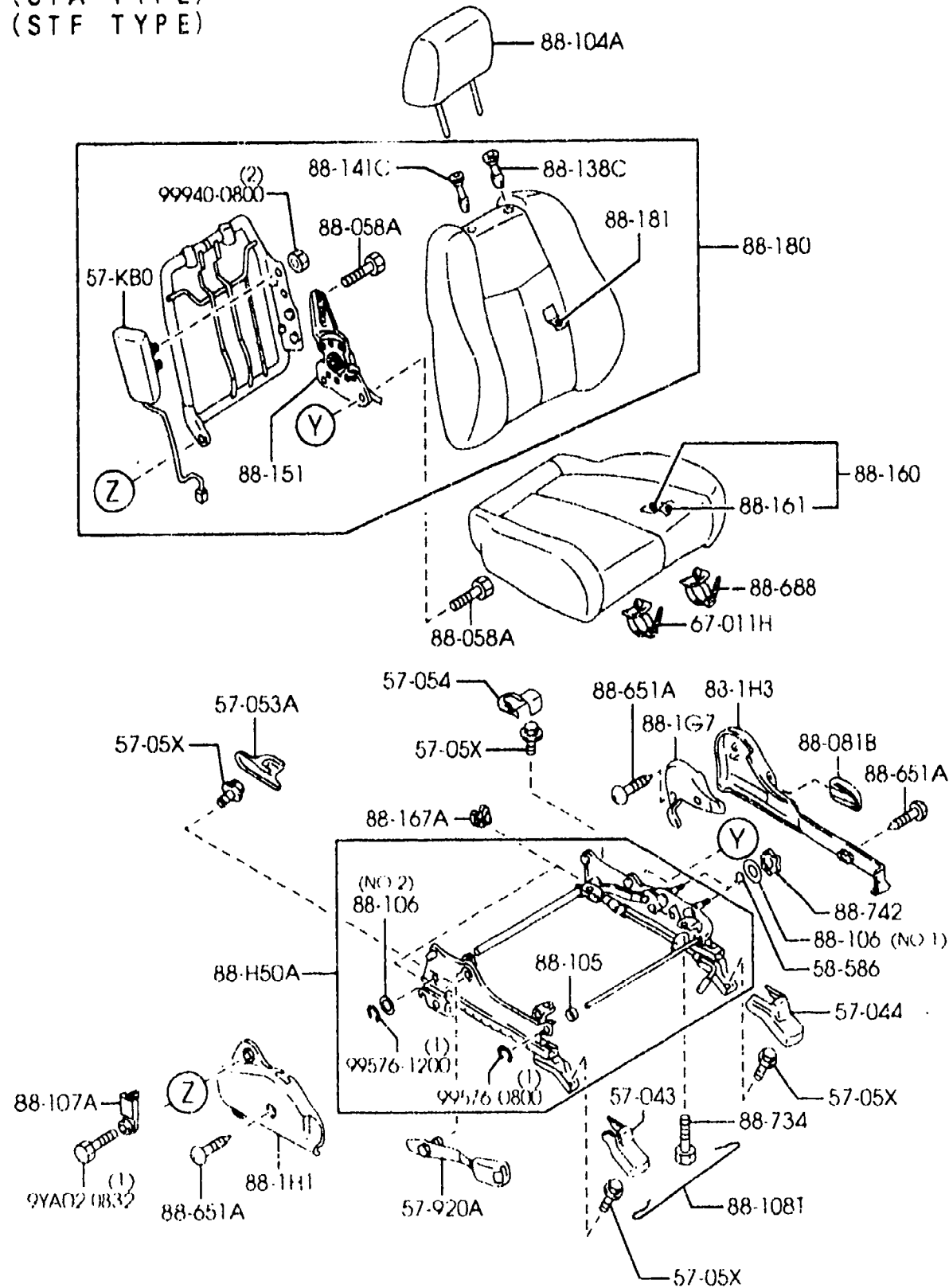

PART NO.	QTY	MODEL/RESTRICTION	MODEL/RESTRICTION	MODEL/RESTRICTION	FROM-TO
57-KAO		MODULE(R)-A/B, SIDE	MODULE(D)-A/R, LATERAL		-1521
B25D-57-KA0C AN(B25D-57-KA0D)	1	(W/SIDE AIR BAG)			1521-
*B25D-57-KA0D	1	(W/SIDE AIR BAG)			
57-KBO		MODULE(L)-A/B, SIDE	MODULE(G)-A/R, LATERAL		-1521
B25D-57-KB0C AN(B25D-57-KB0D)	1	(W/SIDE AIR BAG)			1521-
*B25D-57-KB0D	1	(W/SIDE AIR BAG)			
57-041B		COVER NO.1, ADJ-FRT	COUVERCLE NO.1, ADJUSTEUR		
GE4T-57-041B	1				
05	INT-	BN1 BN2 GRAY	BN1 BN2 GRIS		
65	INT-	BN4 OFF-BLACK	BN4 NOIR CLAIR		
80	INT-	BN3 BEIGE	BN3 BEIGE		
57-042		COVER NO.2, ADJ-FRT	COUVERCLE NO.2, REGUL.-AV.		
GE4T-57-042B	1				
05	INT-	BN1 BN2 GRAY	BN1 BN2 GRIS		
65	INT-	BN4 OFF-BLACK	BN4 NOIR CLAIR		
80	INT-	BN3 BEIGE	BN3 BEIGE		
57-043		COVER NO.3, ADJ-FRT	COUV.NO.3, REGUL.-AV		
GE4T-57-043B	1				
05	INT-	BN1 BN2 GRAY	BN1 BN2 GRIS		
65	INT-	BN4 OFF-BLACK	BN4 NOIR CLAIR		
80	INT-	BN3 BEIGE	BN3 BEIGE		
57-044		COVER NO.4, ADJ-FRT	COUVERCLE NO.4, ADJUSTEUR		
GE4T-57-044B	1				
05	INT-	BN1 BN2 GRAY	BN1 BN2 GRIS		
65	INT-	BN4 OFF-BLACK	BN4 NOIR CLAIR		
80	INT-	BN3 BEIGE	BN3 BEIGE		
57-05X		BOLT, LINK	BOULON, CHAINION		
B455-57-05XB	8				
57-051A		COVER 'A', ADJUSTER-RR	COUVERCLE 'A', REGLEUR-AR		
B25D-57-051B	1				

1521 BJ22\* -475301







(DRIVER SIDE)  
(STB TYPE)  
(STC TYPE)  
(STE TYPE)

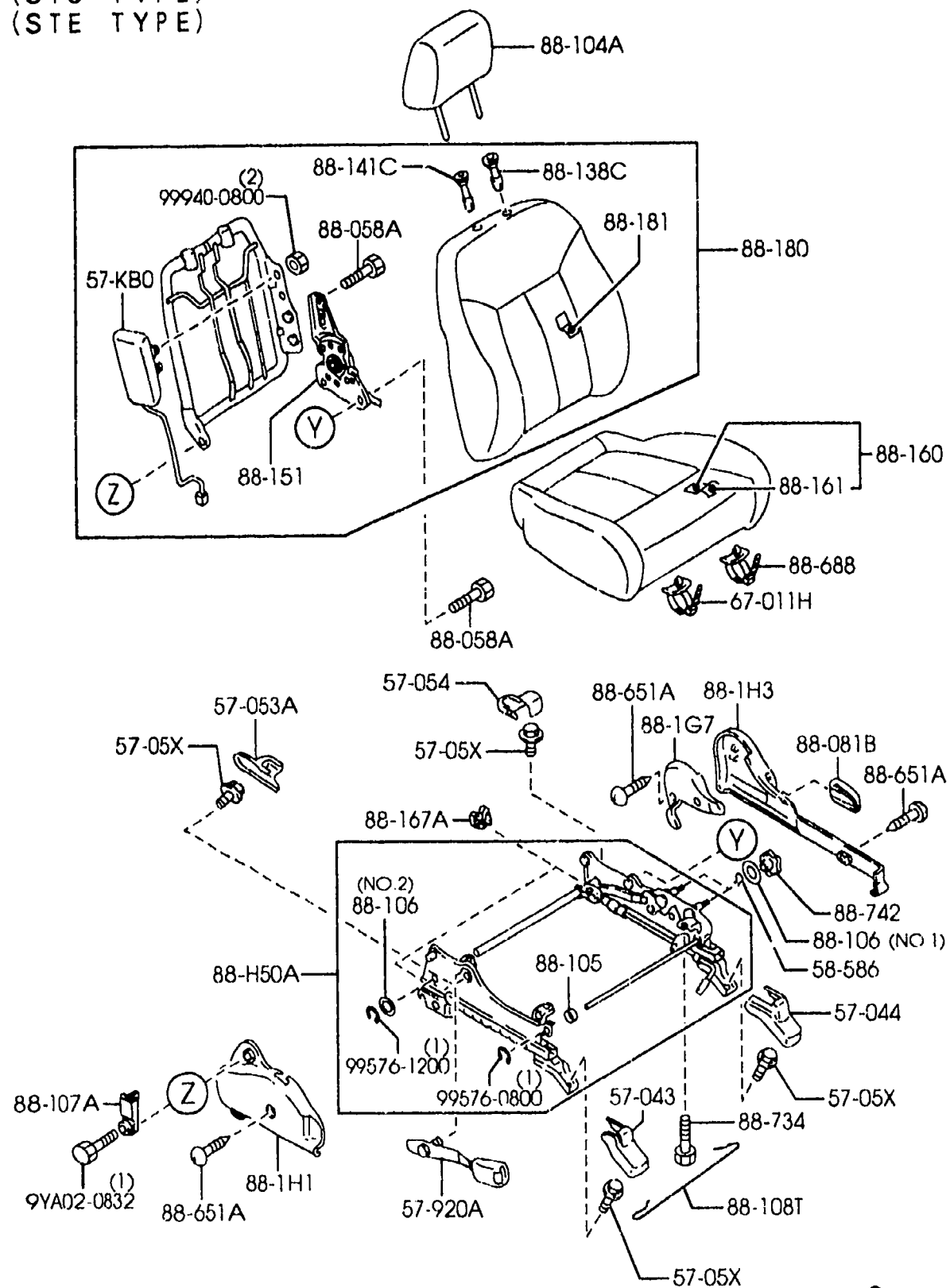

(2B66664)

PART NO.	QTY	MODEL/RESTRICTION	MODEL/RESTRICTION	MODEL/RESTRICTION	FROM-TO
88-103		COVER NO.2, SIDE-F. SEAT	CACHE NO.2, LAT.-SIEGE AV		
B25D-88-1G3A	1				
05	INT-	BN2 GRAY	BN2 GRIS		
65	INT-	BN1 BN4 OFF-BLACK	BN1 BN4 NOIR CLAIR		
80	INT-	BN3 BEIGE	BN3 BEIGE		
88-107		COVER NO.4, REVERSE	COUVERT. NO.4, INVERSE		
B25D-88-1G7	1				
05	INT-	BN2 GRAY	BN2 GRIS		
65	INT-	BN1 BN4 OFF-BLACK	BN1 BN4 NOIR CLAIR		
80	INT-	BN3 BEIGE	BN3 BEIGE		
88-1H1		COVER NO.3, SIDE-F. SEAT	CACHE NO.3, LAT.-SIEGE AV		
B25D-88-1H1A	1				
05	INT-	BN2 GRAY	BN2 GRIS		
65	INT-	BN1 BN4 OFF-BLACK	BN1 BN4 NOIR CLAIR		
80	INT-	BN3 BEIGE	BN3 BEIGE		
88-1H3		COVER NO.4, SIDE-F. SEAT	CACHE NO.4, LAT.-SIEGE AV		
B25D-88-1H3	1				
05	INT-	BN2 GRAY	BN2 GRIS		
65	INT-	BN1 BN4 OFF-BLACK	BN1 BN4 NOIR CLAIR		
80	INT-	BN3 BEIGE	BN3 BEIGE		
88-101		KNUCKLE(R), RECLINING	CHARNIERE D'INCLINAISON (D)		
B25D-88-101	1				
88-102		ADJUSTER, NO.1	REGLAGE NO 1		
B25D-88-102A	1				
88-103		ADJUSTER, NO.2	REGLAGE NO 2		
B25D-88-103A	1				
88-104A		RESTRAINT, HEAD	REPOSE-TETE		
B25E-88-140	2	(STF TYPE)			
65	INT-	BN4 OFF-BLACK	BN4 NOIR CLAIR		
B30D-88-140	2	(STA TYPE)			
19	INT-	BN1 DARK GRAY	BN1 GRIS FONCE		



(PASSENGER SIDE)  
(STB TYPE)  
(STC TYPE)  
(STD TYPE)  
(STE TYPE)  
(STG TYPE)

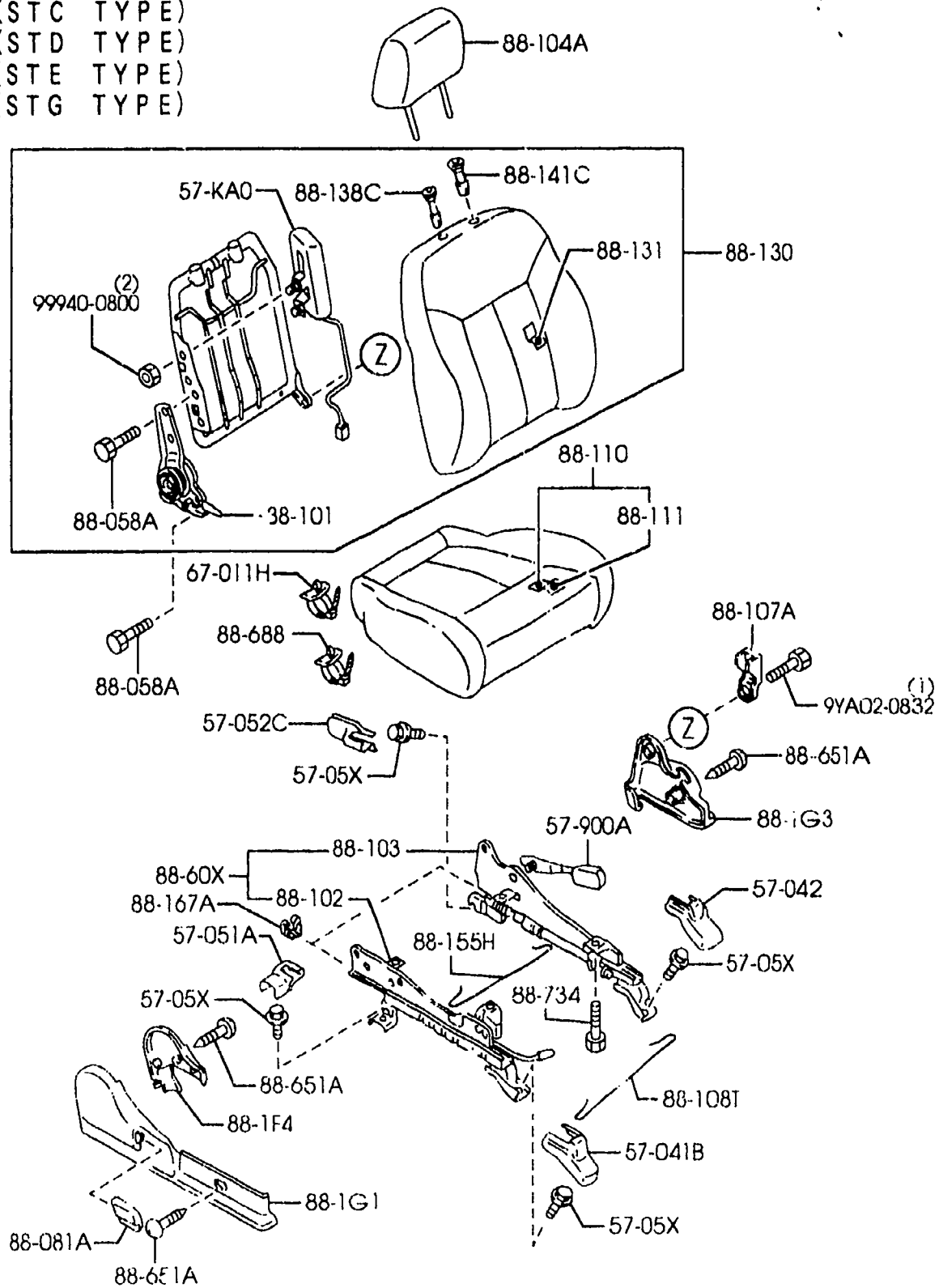

PART NO.	QTY	MODEL/RESTRICTION	MODEL/RESTRICTION	MODEL/RESTRICTION	FROM-TO
<b>CONT'D</b>					
65	INT-	BN4 OFF-BLACK	BN4 NOIR CLAIR		
80	INT-	BN3 BEIGE	BN3 BEIGE		
B30F-88-140	2	(STD TYPE) (STG TYPE)			
05	INT-	BN2 GRAY	BN2 GRIS		
80	INT-	BN3 BEIGE	BN3 BEIGE		
B30G-88-140	2	(STB TYPE) (STC TYPE) (STE TYPE)			
65	INT-	BN1 DARK GRAY/GRAY	BN1 GRIS FONCE/GRIS		
80	INT-	BN3 BEIGE	BN3 BEIGE		
		88-105	BUSH	BUSELURE	
B25E-88-033	1	(STA TYPE) (STB TYPE) (STF TYPE) (STC TYPE)			
		88-106	WASHER	RONDELLE	
B25E-88-044	2	(ILLUST. NO.1) (STA TYPE) (STB TYPE) (STF TYPE) (STC TYPE)			
CB01-88-044	1	(ILLUST. NO.2) (STA TYPE) (STB TYPE) (STF TYPE) (STC TYPE)			
		88-107A	COVER, HINGE	CACHE DE CHARNIERE	
B25D-88-1J2	2				
05	INT-	BN2 GRAY	BN2 GRIS		
65	INT-	BN1 BN4 OFF-BLACK	BN1 BN4 NOIR CLAIR		
80	INT-	BN3 BEIGE	BN3 BEIGE		
		88-108T	WIRE, RELEASE	CABLE DE DEGAGEMENT	
B25D-88-026A	2				
		88-110	CUSHION(R), FRT SEAT	HOUSSE DE SIEGE (D)	
BL8D-88-110	1	(STA TYPE+W/O SIDE A IR BAG)			-1201
65	INT-	BN4 OFF-BLACK	BN4 NOIR CLAIR		
BL8E-88-110	1	(STB TYPE+W/O SIDE A			-1201

1201 BJ22\* -430345





(PASSENGER SIDE)  
(STA TYPE)  
(STF TYPE)

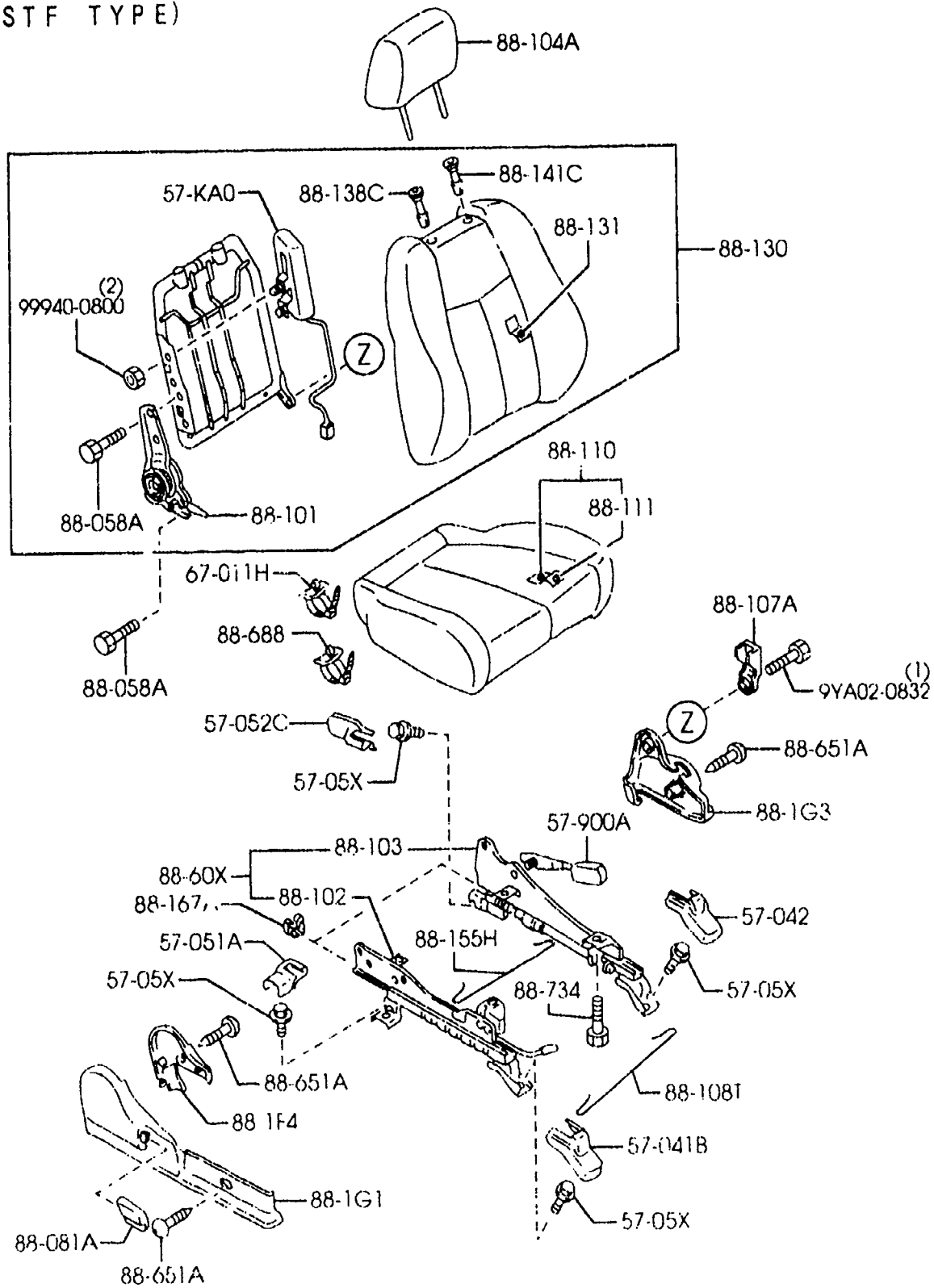

PART NO.	QTY	MODEL/RESTRICTION	MODFL/RESTRICTION	MODEL/RESTRICTION	FROM-TO
<b>CONT'D</b>					
		BAG) (STE TYPE+W/SIDE AIR BAG)			
65	INT-	BN1 DARK GRAY/GRAY	BN1 GRIS FONCE/GRIS		
80	INT-	BN3 BEIGE	BN3 BEIGE		
B30F-88-110A	1	(STD TYPE+W/O SIDE AIR BAG)			1201-1301
05	INT-	BN2 GRAY	BN2 GRIS		
80	INT-	BN3 BEIGE	BN3 BEIGE		
B31F-88-110A	1	(STD TYPE+W/SIDE AIR BAG)			1201-1301
05	INT-	BN2 GRAY	BN2 GRIS		
80	INT-	BN3 BEIGE	BN3 BEIGE		
BL8D-88-110B	1	(STA TYPE+W/O SIDE AIR BAG)			1301-
65	INT-	BN4 OFF-BLACK	BN4 NOIR CLAIR		
BL8E-88-110B	1	(STB TYPE+W/O SIDE AIR BAG) (STC TYPE+W/O SIDE AIR BAG) (STE TYPE+W/O SIDE AIR BAG)			1301-
65	INT-	BN1 DARK GRAY/GRAY	BN1 GRIS FONCE/GRIS		
80	INT-	BN3 BEIGE	BN3 BEIGE		
BL8H-88-110B	1	(STA TYPE+W/SIDE AIR BAG)			1301-
65	INT-	BN4 OFF-BLACK	BN4 NOIR CLAIR		
BL6J-88-110B	1	(STB TYPE+W/SIDE AIR BAG) (STC TYPE+W/SIDE AIR BAG) (STE TYPE+W/SIDE AIR BAG)			1301-
65	INT-	BN1 DARK GRAY/GRAY	BN1 GRIS FONCE/GRIS		
80	INT-	BN3 BEIGE	BN3 BEIGE		
BN7H-88-110A	1	(STF TYPE)			1301-
65	INT-	BN4 BLACK/OFF-BLACK	BN4 NOIR/NOIR CLAIR		
B30F-88-110B	1	(STD TYPE+W/O SIDE AIR BAG) (STG TYPE+W/O SIDE AIR BAG)			1301-
05	INT-	BN2 GRAY	BN2 GRIS		
80	INT-	BN3 BEIGE	BN3 BEIGE		
B31F-88-110B	1	(STD TYPE+W/SIDE AIR BAG)			1301-

1201 BJ22\* -430345  
1301 BJ22\* -440775



5700A FRONT SEATS  
(4-DOOR)

(4/5)

(DRIVER SIDE)  
(STB TYPE)  
(STC TYPE)  
(STE TYPE)

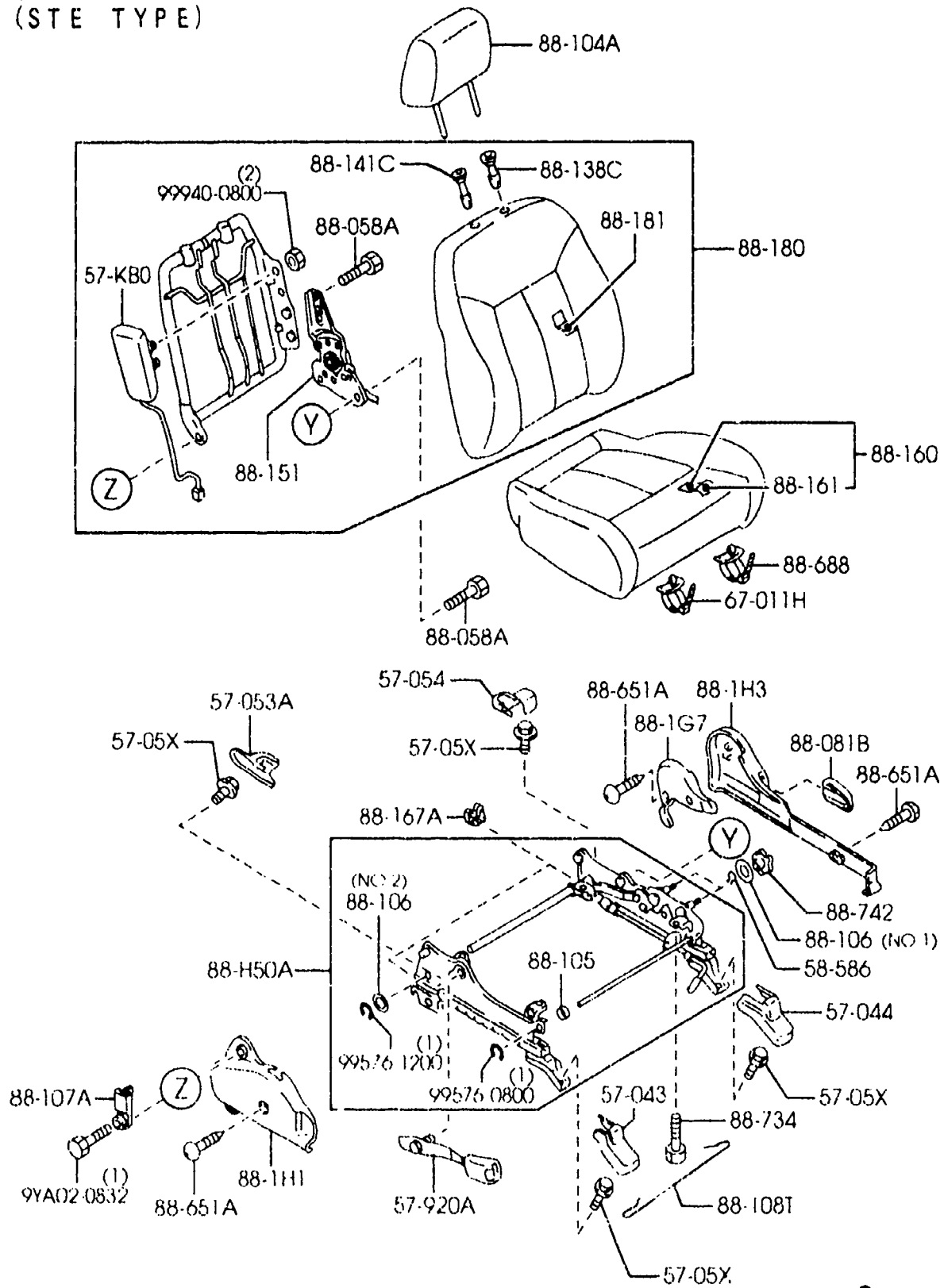

5700A -9 FRONT SEATS  
(4-DOOR)

PART NO.	QTY	MODEL/RESTRICTION	MODIF./RESTRICTION	MODEL/RESTRICTION	FROM-TO
<b>CONT'D</b>					
65	INT-	BN4 OFF-BLACK	BN4 NOIR CLAIR		
BL8J-88-130	1	(STB TYPE+W/SIDE AIR BAG) (STC TYPE+W/SIDE AIR BAG) (STE TYPE+W/SIDE AIR BAG)			-1521
65	INT-	BN1 DARK GRAY/GRAY	BN1 GRIS FONCE/GRIS		
80	INT-	BN3 BEIGE	BN3 BEIGE		
B31F-88-130	1	(STD TYPE+W/SIDE AIR BAG)			-1521
05	INT-	BN2 GRAY	BN2 GRIS		
80	INT-	BN3 BEIGE	BN3 BEIGE		
*BL8H-88-130A	1	(STA TYPE+W/SIDE AIR BAG)			1521-
* 65	INT-	BN4 OFF-BLACK	BN4 NOIR CLAIR		
*BL8J-88-130A	1	(STB TYPE+W/SIDE AIR BAG) (STC TYPE+W/SIDE AIR BAG) (STE TYPE+W/SIDE AIR BAG)			1521-
* 65	INT-	BN1 DARK GRAY/GRAY	BN1 GRIS FONCE/GRIS		
* 80	INT-	BN3 BEIGE	BN3 BEIGE		
*B31F-88-130A	1	(STD TYPE+W/SIDE AIR BAG) (STG TYPE+W/SIDE AIR BAG)			1521-
* 05	INT-	BN2 GRAY	BN2 GRIS		
* 80	INT-	BN3 BEIGE	BN3 BEIGE		
		88-131			
BL8D-88-131	1	TRIM(R), SEAT BACK (STA TYPE+W/O SIDE AIR BAG)	GARNITURE (D), SIEGE ARR		
65	INT-	BN4 OFF-BLACK	BN4 NOIR CLAIR		
BL8H-88-131	1	(STA TYPE+W/SIDE AIR BAG)			
65	INT-	BN4 OFF-BLACK	BN4 NOIR CLAIR		
BN7H-88-131	1	(STF TYPE)			
65	INT-	BN4 BLACK/OFF-BLACK	BN4 NOIR/NOIR CLAIR		
B30F-88-131	1	(STD TYPE+W/O SIDE AIR BAG) (STG TYPE+W/O SIDE AIR BAG)			
1521 BJ22* -475301					



AUBA09

(2B66664)

CAT. AUBA09-02

2001-07

3-E14

(PASSENGER SIDE)  
(STB TYPE)  
(STC TYPE)  
(STD TYPE)  
(STE TYPE)  
(STG TYPE)

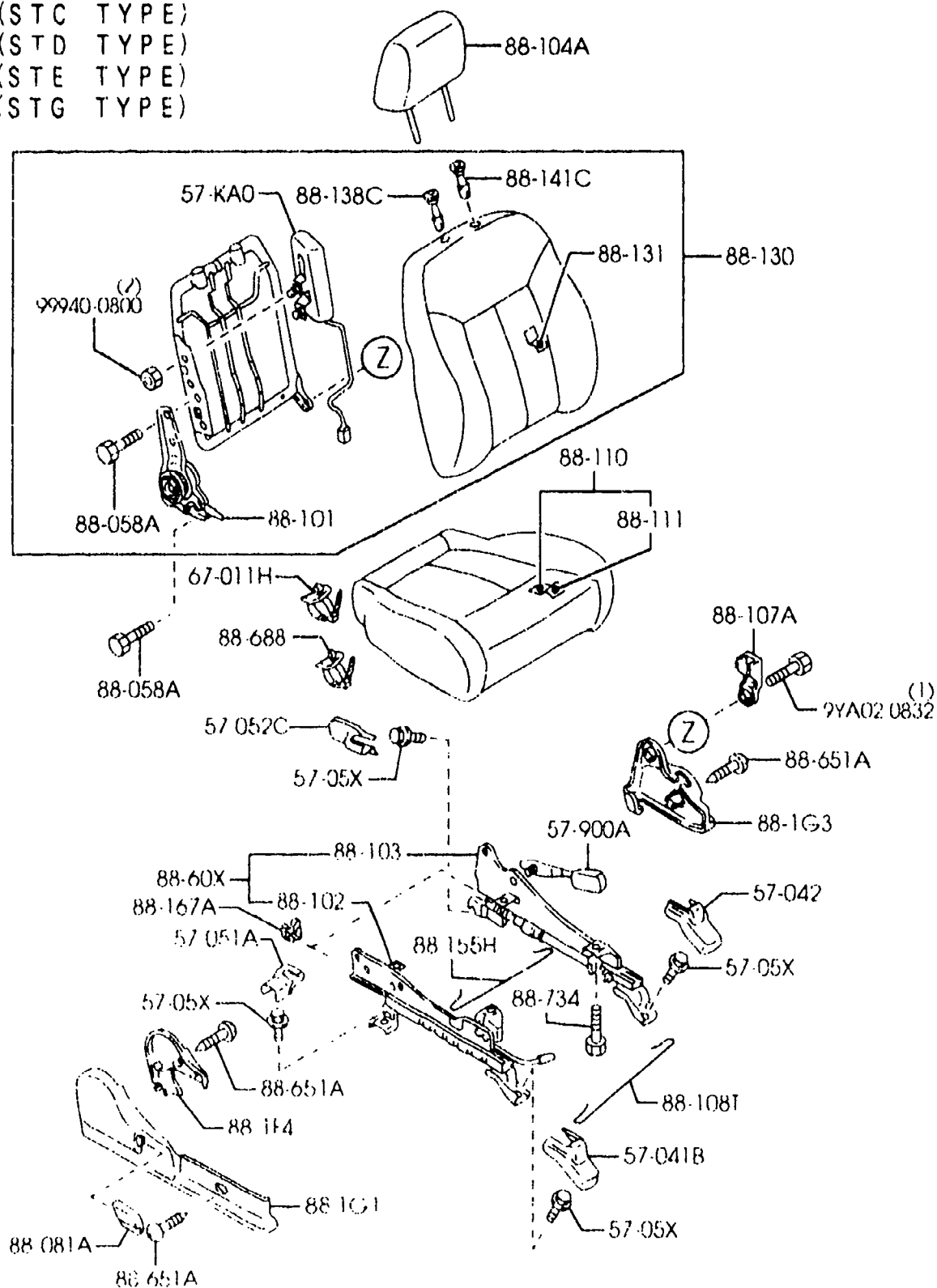

PART NO.	QTY	MODEL/RESTRICTION	MODEL/RESTRICTION	MODEL/RESTRICTION	FROM-TO
CONT'D					
05	INT-	BN2 GRAY	BN2 GRIS		
80	INT-	BN3 BEIGE	BN3 BEIGE		
B30G-88-131	1	(STB TYPE+W/O SIDE AIR BAG) (STC TYPE+W/O SIDE AIR BAG) (STE TYPE+W/O SIDE AIR BAG)			
65	INT-	BN1 DARK GRAY/GRAY	BN1 GRIS FONCE/GRIS		
80	INT-	BN3 BEIGE	BN3 BEIGE		
B31F-88-131	1	(STD TYPE+W/SIDE AIR BAG) (STG TYPE+W/SIDE AIR BAG)			
05	INT-	BN2 GRAY	BN2 GRIS		
80	INT-	BN3 BEIGE	BN3 BEIGE		
B31G-88-131	1	(STB TYPE+W/SIDE AIR BAG) (STC TYPE+W/SIDE AIR BAG) (STE TYPE+W/SIDE AIR BAG)			
65	INT-	BN1 DARK GRAY/GRAY	BN1 GRIS FONCE/GRIS		
80	INT-	BN3 BEIGE	BN3 BEIGE		
88-138C		GUIDE, POLE-NO.2	GUIDE, MAT NO 2		
B25D-88-1G9A	2				
05	INT-	BN2 GRAY	BN2 GRIS		
65	INT-	BN1 BN4 OFF-BLACK	BN1 BN4 NOIR CLAIR		
80	INT-	BN3 BEIGE	BN3 BEIGE		
88-141C		GUIDE, POLE-NO.1	GUIDE, MAT NO 1		
B25D-88-1G8A	2				
05	INT-	BN2 GRAY	BN2 GRIS		
65	INT-	BN1 BN4 OFF-BLACK	BN1 BN4 NOIR CLAIR		
80	INT-	BN3 BEIGE	BN3 BEIGE		
88-151		KNUCKLE(L), RECLINING	CHARNIERE D'INCLINAISON (		
B25D-88-155	1				
88-152		ADJUSTER NO.3	REGLAGE NO 3		
B25D-88-152A	1	(STD TYPE) (STE TYPE) (STG TYPE)			

5700A FRONT SEATS  
(4-DOOR)

(1/5)

(DRIVER SIDE)  
(STA TYPE)  
(STF TYPE)

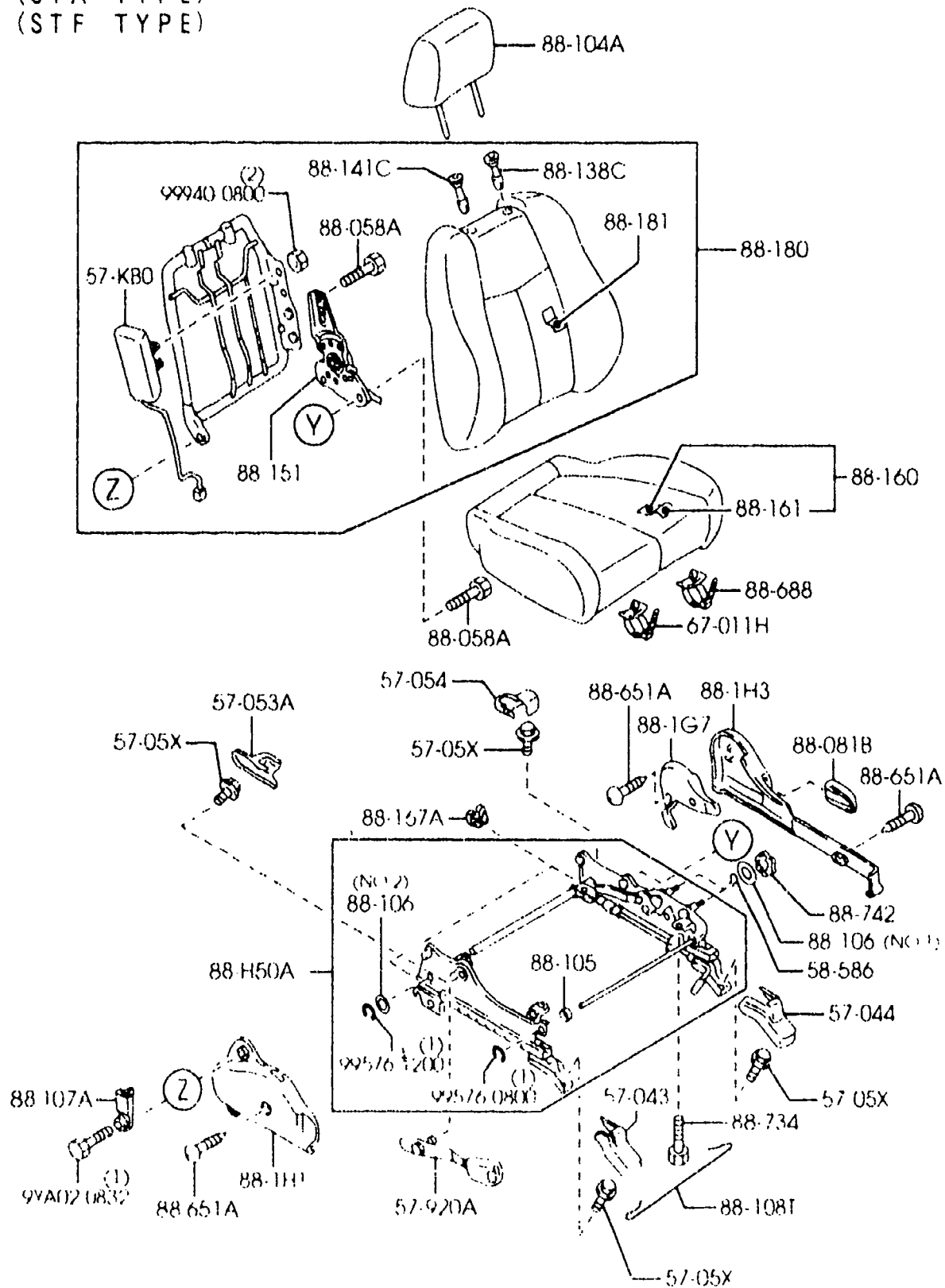

5700A -11 FRONT SEATS  
(4-DOOR)

PART NO.	QTY	MODEL/RESTRICTION	MODEL/RESTRICTION	MODEL/RESTRICTION	FROM-TO
88-153		ADJUSTER NO.4	REGLAGE NO 4		
B25D-88-153A	1	(STD TYPE) (STE TYPE) (STG TYPE)			
88-155H		WIRE,SUPPORTING	FIL METALLIQUE,SUPPO RT		
B25D-88-029	1	(STA TYPE) (STB TYPE) (STC TYPE) (STF TYPE)			
B25D-88-029	2	(STD TYPE) (STE TYPE) (STG TYPE)			
88-160		CUSHION(L),FRT SEAT	HOUSSE DE SIEGE (G)		
BL8D-88-160	1	(STA TYPE+W/O SIDE A IR BAG)			-1201
65	INT-	BN4 OFF-BLACK	BN4 NOIR CLAIR		
BL8E-88-160	1	(STB TYPE+W/O SIDE A IR BAG) (STC TYPE+W/O SIDE A IR BAG)			-1201
65	INT-	BN1 DARK GRAY/GRAY	BN1 GRIS FONCE/GRIS		
80	INT-	BN3 BEIGE	BN3 BEIGE		
BL8H-88-160	1	(STA TYPE+W/SIDE AIR BAG)			-1201
65	INT-	BN4 OFF-BLACK	BN4 NOIR CLAIR		
BL8J-88-160	1	(STB TYPE+W/SIDE AIR BAG) (STC TYPE+W/SIDE AIR BAG)			-1201
65	INT-	BN1 DARK GRAY/GRAY	BN1 GRIS FONCE/GRIS		
80	INT-	BN3 BEIGE	BN3 BEIGE		
B30F-88-160	1	(STD TYPE+W/O SIDE A IR BAG)			-1201
05	INT-	BN2 GRAY	BN2 GRIS		
80	INT-	BN3 BEIGE	BN3 BEIGE		
B31F-88-160	1	(STD TYPE+W/SIDE AIR BAG)			-1201
05	INT-	BN2 GRAY	BN2 GRIS		
80	INT-	BN3 BEIGE	BN3 BEIGE		
BN7H-88-160	1	(STF TYPE)			-1301
65	INT-	BN4 BLACK/OFF-BLACK	BN4 NOIR/NOIR CLAIR		
B30G-88-160A	1	(STE TYPE+W/O SIDE A			-1301

1201 BJ22\* -430345  
1301 BJ22\* -440775



AUBA09

(2B6661)

CAT. AUBA09-02

2001-07

3-G14

(PASSENGER SIDE)  
(STA TYPE)  
(STF TYPE)

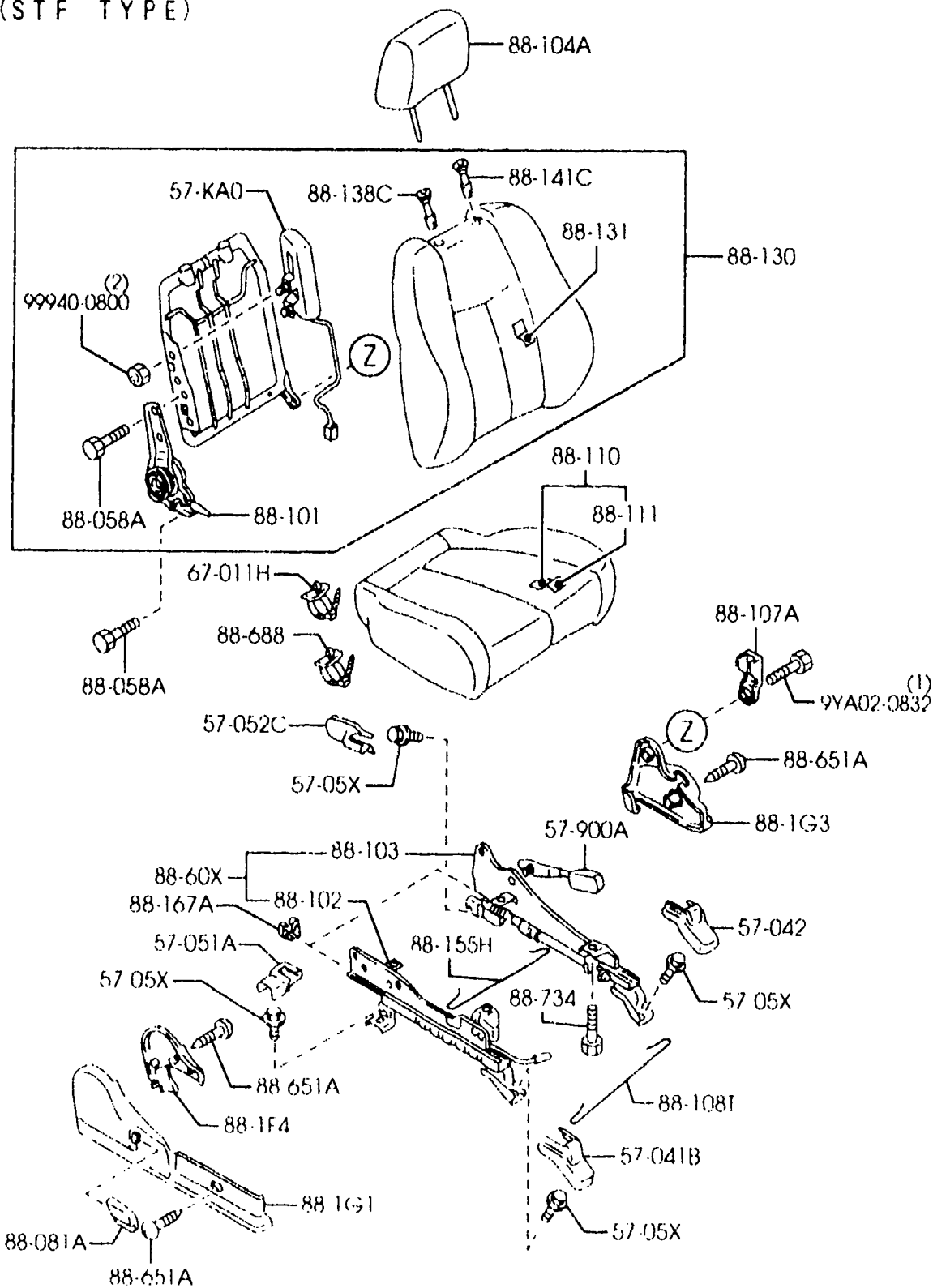

PART NO.	QTY	MODEL/RESTRICTION	MODEL/RESTRICTION	MODEL/RESTRICTION	FROM-TO
CONT'D					
		IR BAG)			
65	INT-	BN1 DARK GRAY/GRAY	BN1 GRIS FONCE/GRIS		
80	INT-	BN3 BEIGE	BN3 BEIGE		
B31G-88-160A	1	(STE TYPE+W/SIDE AIR BAG)			-1301
65	INT-	BN1 DARK GRAY/GRAY	BN1 GRIS FONCE/GRIS		
80	INT-	BN3 BEIGE	BN3 BEIGE		
BL8D-88-160A	1	(STA TYPE+W/O SIDE AIR BAG)			1201-1301
65	INT-	BN4 OFF-BLACK	BN4 NOIR CLAIR		
BL8E-88-160A	1	(STB TYPE+W/O SIDE AIR BAG) (STC TYPE+W/O SIDE AIR BAG)			1201-1301
65	INT-	BN1 DARK GRAY/GRAY	BN1 GRIS FONCE/GRIS		
80	INT-	BN3 BEIGE	BN3 BEIGE		
BL8H-88-160A	1	(STA TYPE+W/SIDE AIR BAG)			1201-1301
65	INT-	BN4 OFF-BLACK	BN4 NOIR CLAIR		
BL8J-88-160A	1	(STB TYPE+W/SIDE AIR BAG) 'STC TYPE+W/SIDE AIR BAG)			1201-1301
65	INT-	BN1 DARK GRAY/GRAY	BN1 GRIS FONCE/GRIS		
80	INT-	BN3 BEIGE	BN3 BEIGE		
B30F-88-160A	1	(STD TYPE+W/O SIDE AIR BAG)			1201-1301
05	INT-	BN2 GRAY	BN2 GRIS		
80	INT-	BN3 BEIGE	BN3 BEIGE		
B31F-88-160A	1	(STD TYPE+W/SIDE AIR BAG)			1201-1301
05	INT-	BN2 GRAY	BN2 GRIS		
80	INT-	BN3 BEIGE	BN3 BEIGE		
BL8D-88-160B	1	(STA TYPE+W/O SIDE AIR BAG)			1301-
65	INT-	BN4 OFF-BLACK	BN4 NOIR CLAIR		
BL8E-88-160B	1	(STB TYPE+W/O SIDE AIR BAG) (STC TYPE+W/O SIDE AIR BAG)			1301-
65	INT-	BN1 DARK GRAY/GRAY	BN1 GRIS FONCE/GRIS		
80	INT-	BN3 BEIGE	BN3 BEIGE		
BL8H-88-160B	1	(STA TYPE+W/SIDE AIR			1301-
1201 BJ22* -430345					
1301 BJ22* -440775					



(DRIVER SIDE)  
(STD TYPE)  
(STG TYPE)

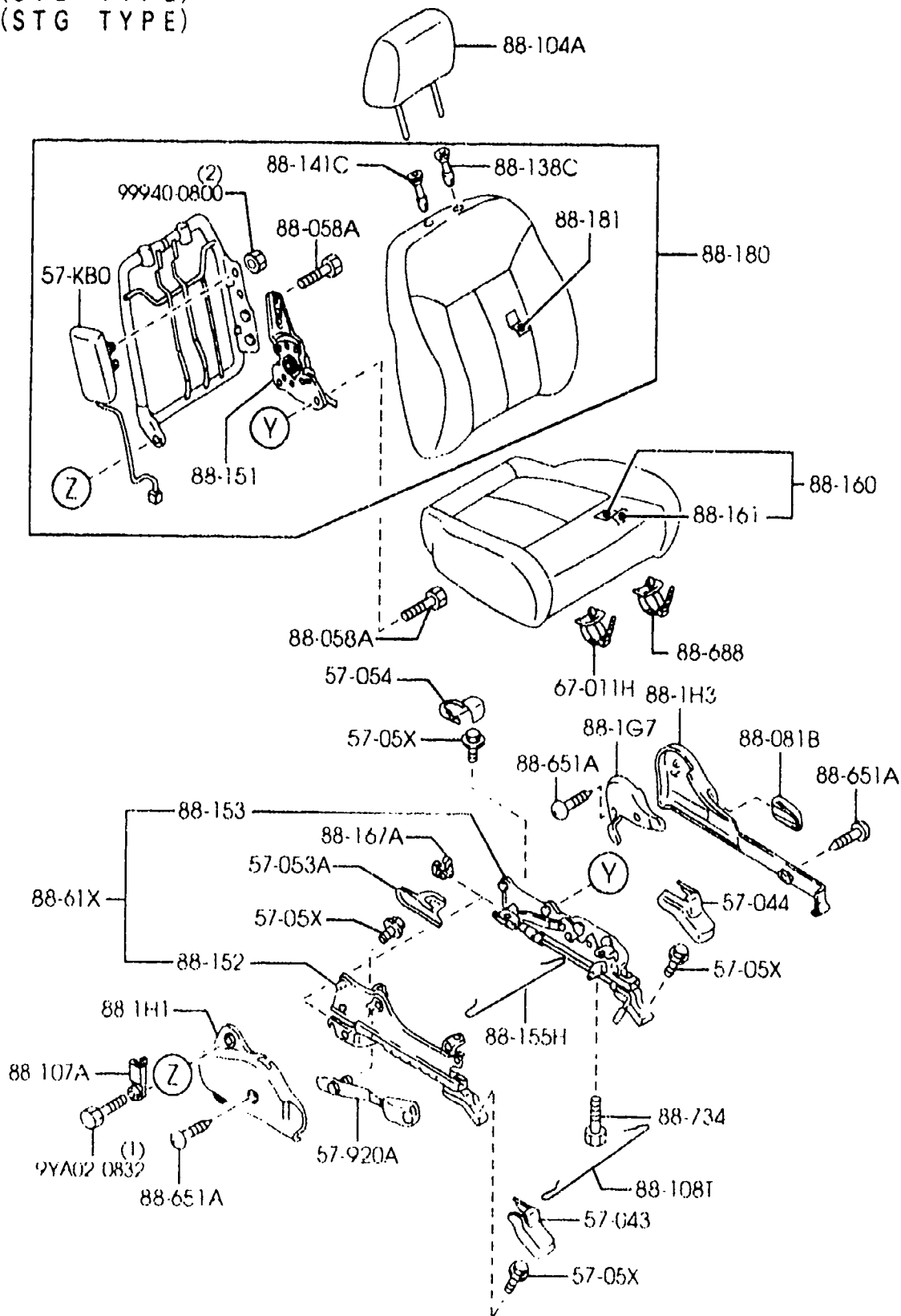

PART NO.	QTY	MODEL/RESTRICTION	MODEL/RESTRICTION	MODEL/RESTRICTION	FROM-TO
<b>CONT'D</b>					
65	INT-	BAG)			
65	INT-	BN4 OFF-BLACK	BN4 NOIR CLAIR		
BL8J-88-160B	1	(STB TYPE+W/SIDE AIR BAG) (STC TYPE+W/SIDE AIR BAG)			1301-
65	INT-	BN1 DARK GRAY/GRAY	BN1 GRIS FONCE/GRIS		
80	INT-	BN3 BEIGE	BN3 BEIGE		
BN7H-88-160A	1	(STF TYPE)			1301-
65	INT-	BN4 BLACK/OFF-BLACK	BN4 NOIR/NOIR CLAIR		
B30F-88-160B	1	(STD TYPE+W/O SIDE AIR BAG) (STG TYPE+W/O SIDE AIR BAG)			1301-
05	INT-	BN2 GRAY	BN2 GRIS		
80	INT-	BN3 BEIGE	BN3 BEIGE		
B30G-88-160B	1	(STE TYPE+W/O SIDE AIR BAG)			1301-
65	INT-	BN1 DARK GRAY/GRAY	BN1 GRIS FONCE/GRIS		
80	INT-	BN3 BEIGE	BN3 BEIGE		
B31F-88-160B	1	(STD TYPE+W/SIDE AIR BAG) (STG TYPE+W/SIDE AIR BAG)			1301-
05	INT-	BN2 GRAY	BN2 GRIS		
80	INT-	BN3 BEIGE	BN3 BEIGE		
B31G-88-160B	1	(STE TYPE+W/SIDE AIR BAG)			1301-
65	INT-	BN1 DARK GRAY/GRAY	BN1 GRIS FONCE/GRIS		
80	INT-	BN3 BEIGE	BN3 BEIGE		
		TRIM(L), SEAT CUSHION	HOUSSE DE SIEGE (G)		
BL8D-88-161	1	(STA TYPE+W/O SIDE AIR BAG)			
65	INT-	BN4 OFF-BLACK	BN4 NOIR CLAIR		
BL8E-88-161	1	(STB TYPE+W/O SIDE AIR BAG) (STC TYPE+W/O SIDE AIR BAG)			
65	INT-	BN1 DARK GRAY/GRAY	BN1 GRIS FONCE/GRIS		
80	INT-	BN3 BEIGE	BN3 BEIGE		
BL8H-88-161	1	(STA TYPE+W/SIDE AIR BAG)			
1301 BJ22* -440775					



(DRIVER SIDE)  
(STB TYPE)  
(STC TYPE)  
(STE TYPE)

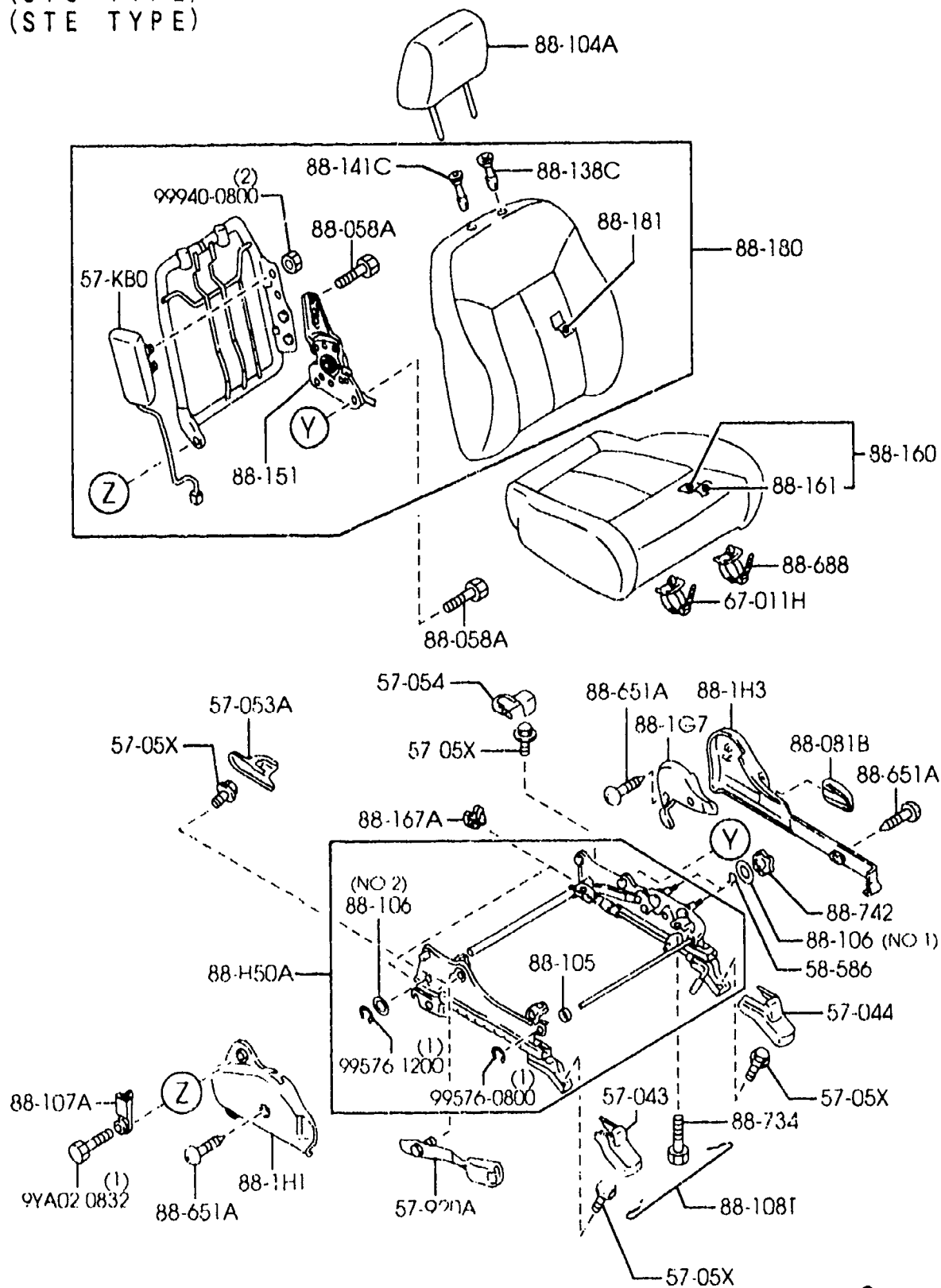

AUBA09

(2B66664)

PART NO.	QTY	MODEL/RESTRICTION	MODEL/RESTRICTION	MODEL/RESTRICTION	FROM-TO
<b>CONT'D</b>					
65	INT-	BN4 OFF-BLACK	BN4 NOIR CLAIR		
BL8J-88-161	1	(STB TYPE+W/SIDE AIR BAG) (STC TYPE+W/SIDE AIR BAG)			
65	INT-	BN1 DARK GRAY/GRAY	BN1 GRIS FONCE/GRIS		
80	INT-	BN3 BEIGE	BN3 BEIGE		
BN7H-88-161	1	(STF TYPE)			
65	INT-	BN4 BLACK/OFF-BLACK	BN4 NOIR/NOIR CLAIR		
B30F-88-161	1	(STD TYPE) (STG TYPE)			
05	INT-	BN2 GRAY	BN2 GRIS		
80	INT-	BN3 BEIGE	BN3 BEIGE		
B30G-88-161	1	(STE TYPE)			
65	INT-	BN1 DARK GRAY/GRAY	BN1 GRIS FONCE/GRIS		
80	INT-	BN3 BEIGE	BN3 BEIGE		
		88-167A	PROTECTOR	PROTECTEUR	
B25D-88-091	4				
		88-180	BACK(L), FRONT SEAT	SIEGE(G), ARRIERE	
BL8D-88-180	1	(STA TYPE+W/O SIDE AIR BAG)			
65	INT-	BN4 OFF-BLACK	BN4 NOIR CLAIR		
BL8E-88-180	1	(STB TYPE+W/O SIDE AIR BAG) (STC TYPE+W/O SIDE AIR BAG) (STE TYPE+W/O SIDE AIR BAG)			
65	INT-	BN1 DARK GRAY/GRAY	BN1 GRIS FONCE/GRIS		
80	INT-	BN3 BEIGE	BN3 BEIGE		
BL8F-88-180	1	(STD TYPE+W/O SIDE AIR BAG) (STG TYPE+W/O SIDE AIR BAG)			
05	INT-	BN2 GRAY	BN2 GRIS		
80	INT-	BN3 BEIGE	BN3 BEIGE		
BN7H-88-180	1	(STF TYPE)			
65	INT-	BN4 BLACK/OFF-BLACK	BN4 NOIR/NOIR CLAIR		
BL8H-88-180	1	(STA TYPE+W/SIDE AIR BAG)			-1521

1521 BJ22\* -475301

CAT. AUBA09-02

2001-07

5700A FRONT SEATS  
(4-DOOR)

(5/5)

(PASSENGER SIDE)  
(STB TYPE)  
(STC TYPE)  
(STD TYPE)  
(STE TYPE)  
(STG TYPE)

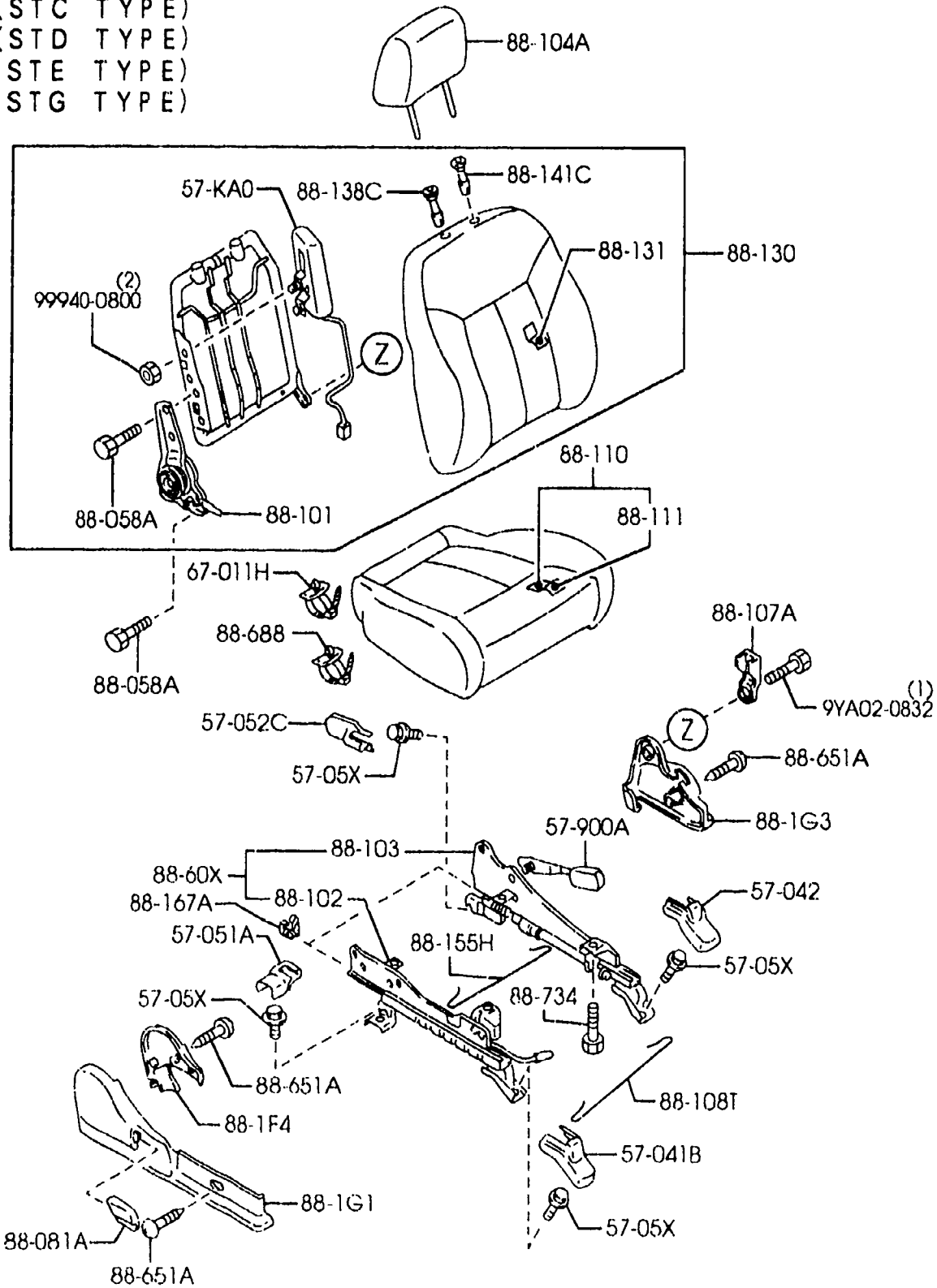

5700A -15 FRONT SEATS  
(4-DOOR)

PART NO.	QTY	MODEL/RESTRICTION	MODEL/RESTRICTION	MODEL/RESTRICTION	FROM-TO
<b>CONT'D</b>					
65	INT-	BN4 OFF-BLACK	BN4 NOIR CLAIR		
BL8J-88-180	1	(STB TYPE+W/SIDE AIR BAG) (STC TYPE+W/SIDE AIR BAG) (STE TYPE+W/SIDE AIR BAG)			-1521
65	INT-	BN1 DARK GRAY/GRAY	BN1 GRIS FONCE/GRIS		
80	INT-	BN3 BEIGE	BN3 BEIGE		
BL8K-88-180	1	(STD TYPE+W/SIDE AIR BAG)			-1521
05	INT-	BN2 GRAY	BN2 GRIS		
80	INT-	BN3 BEIGE	BN3 BEIGE		
*BL8H-88-180A	1	(STA TYPE+W/SIDE AIR BAG)			1521-
* 65	INT-	BN4 OFF-BLACK	BN4 NOIR CLAIR		
*BL8J-88-180A	1	(STB TYPE+W/SIDE AIR BAG) (STC TYPE+W/SIDE AIR BAG) (STE TYPE+W/SIDE AIR BAG)			1521-
* 65	INT-	BN1 DARK GRAY/GRAY	BN1 GRIS FONCE/GRIS		
* 80	INT-	BN3 BEIGE	BN3 BEIGE		
*BL8K-88-180A	1	(STD TYPE+W/SIDE AIR BAG) (STG TYPE+W/SIDE AIR BAG)			1521-
* 05	INT-	BN2 GRAY	BN2 GRIS		
* 80	INT-	BN3 BEIGE	BN3 BEIGE		
		+-----+   88-181   +-----+	TRIM(L), SEAT BACK	HOUSSE (G), SIEGE AR	
BL8D-88-181	1	(STA TYPE+W/O SIDE AIR BAG)			
65	INT-	BN4 OFF-BLACK	BN4 NOIR CLAIR		
BL8E-88-181	1	(STB TYPE+W/O SIDE AIR BAG) (STC TYPE+W/O SIDE AIR BAG) (STE TYPE+W/O SIDE AIR BAG)			
65	INT-	BN1 DARK GRAY/GRAY	BN1 GRIS FONCE/GRIS		
80	INT-	BN3 BEIGE	BN3 BEIGE		
BL8F-88-181	1	(STD TYPE+W/O SIDE AIR BAG) (STG TYPE+W/O SIDE AIR BAG)			
1521 BJ22* -475301					

(DRIVER SIDE)  
(STA TYPE)  
(STF TYPE)

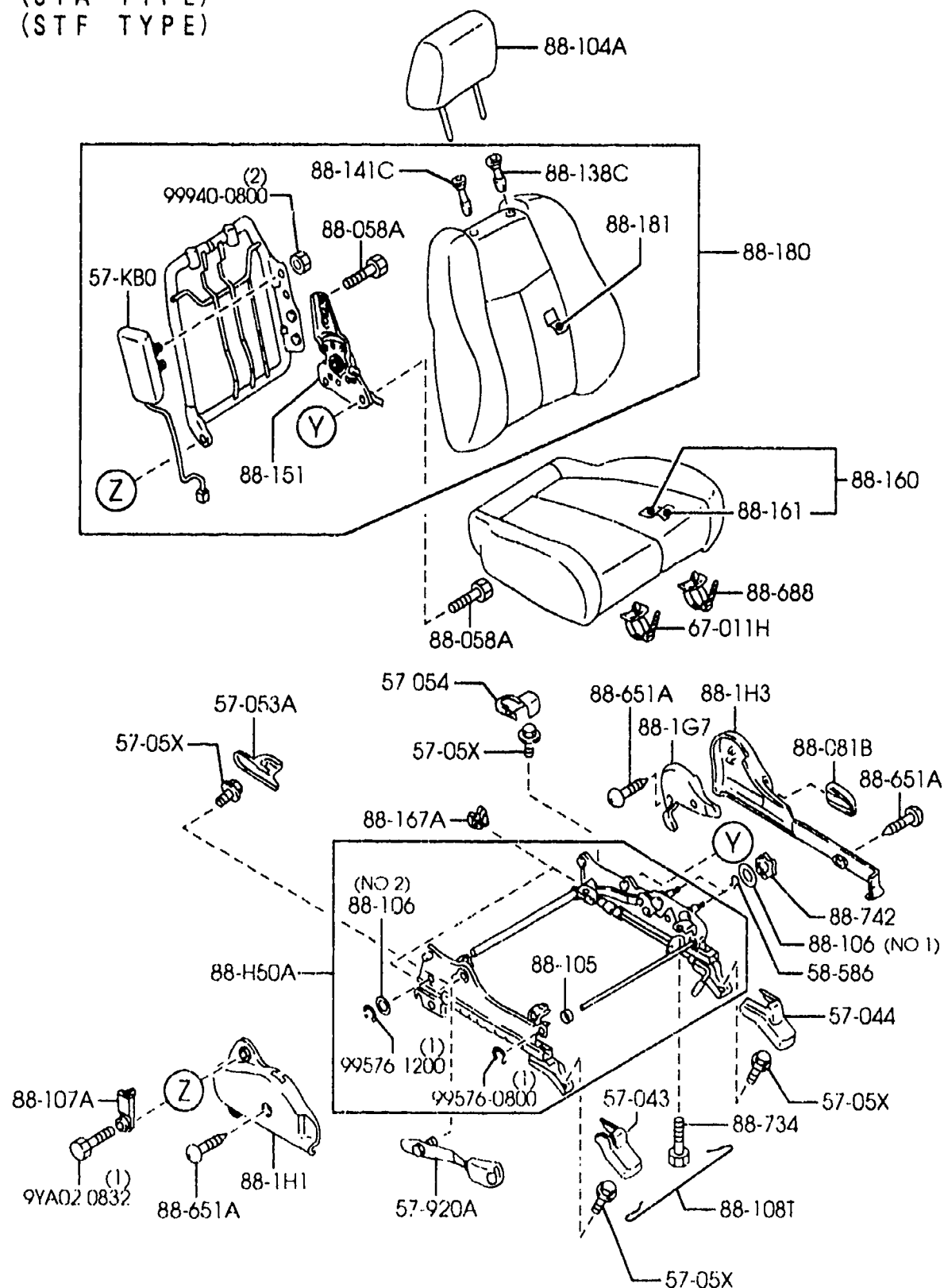

PART NO.	QTY	MODEL/RESTRICTION	MODEL/RESTRICTION	MODEL/RESTRICTION	FROM-TO
CONT'D					
		IR BAG)			
05	INT-	BN2 GRAY	BN2 GRIS		
65	INT-	BN1 DARK GRAY	BN1 GRIS FONCE		
80	INT-	BN3 BEIGE	BN3 BEIGE		
BL8H-88-181	1	(STA TYPE+W/SIDE AIR BAG)			
65	INT-	BN4 OFF-BLACK	BN4 NOIR CLAIR		
BL8J-88-181	1	(STB TYPE+W/SIDE AIR BAG) (STC TYPE+W/SIDE AIR BAG) (STE TYPE+W/SIDE AIR BAG)			
65	INT-	BN1 DARK GRAY/GRAY	BN1 GRIS FONCE/GRIS		
80	INT-	BN3 BEIGE	BN3 BEIGE		
BL8K-88-181	1	(STD TYPE+W/SIDE AIR BAG) (STG TYPE+W/SIDE AIR BAG)			
05	INT-	BN2 GRAY	BN2 GRIS		
65	INT-	BN1 DARK GRAY	BN1 GRIS FONCE		
80	INT-	BN3 BEIGE	BN3 BEIGE		
BN7H-88-181	1	(STF TYPE)			
65	INT-	BN4 BLACK/OFF-BLACK	BN4 NOIR/NOIR CLAIR		
----- 88-60X -----		ADJUSTER UNIT(R),FRT SEAT	DISP. REGLEUR(D),SIEGE AV		
B25D-88-A00B	1				
----- 88-61X -----		ADJUSTER UNIT(L),FRT SEAT	DISP. REGLEUR(G),SIEGE AV		
B25D-88-A50B	1	(STD TYPE) (STE TYPE) (STG TYPE)			
----- 88-651A -----		SCREW,TAPPING	MEMBRURE,VERTICALE		
G211-88-651	8				
----- 88-688 -----		CLIP	ATTACHE		
B25F-88-126	2	(W/SIDE AIR BAG)			
----- 88-734 -----		BOLT	BOULON		
B092-88-818	8				



(PASSENGER SIDE)  
(STA TYPE)  
(STF TYPE)

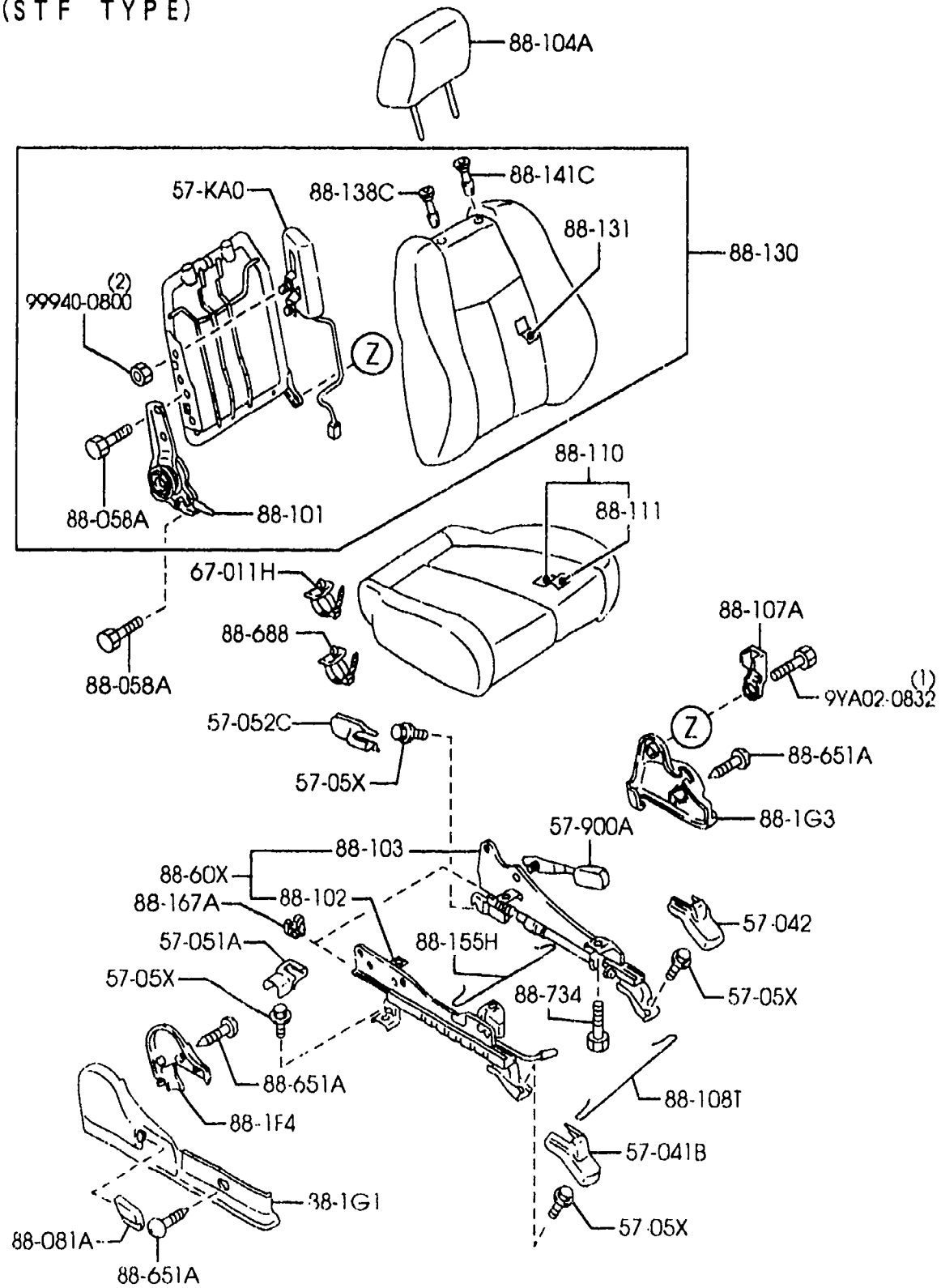

PART NO.	QTY	MODEL/RESTRICTION	MODEL/RESTRICTION	MODEL/RESTRICTION	FROM-TO
88-742		DIAL, SUPPORT	BOUTON		
GE4T-88-1L1	2	(STA TYPE) (STB TYPE) (STF TYPE) (STC TYPE)			
05	INT-	BN2 GRAY	BN2 GRIS		
65	INT-	BN1 BN4 OFF-BLACK	BN1 BN4 NOIR CLAIR		
80	INT-	BN3 BEIGE	BN3 BEIGE		



(DRIVER SIDE)

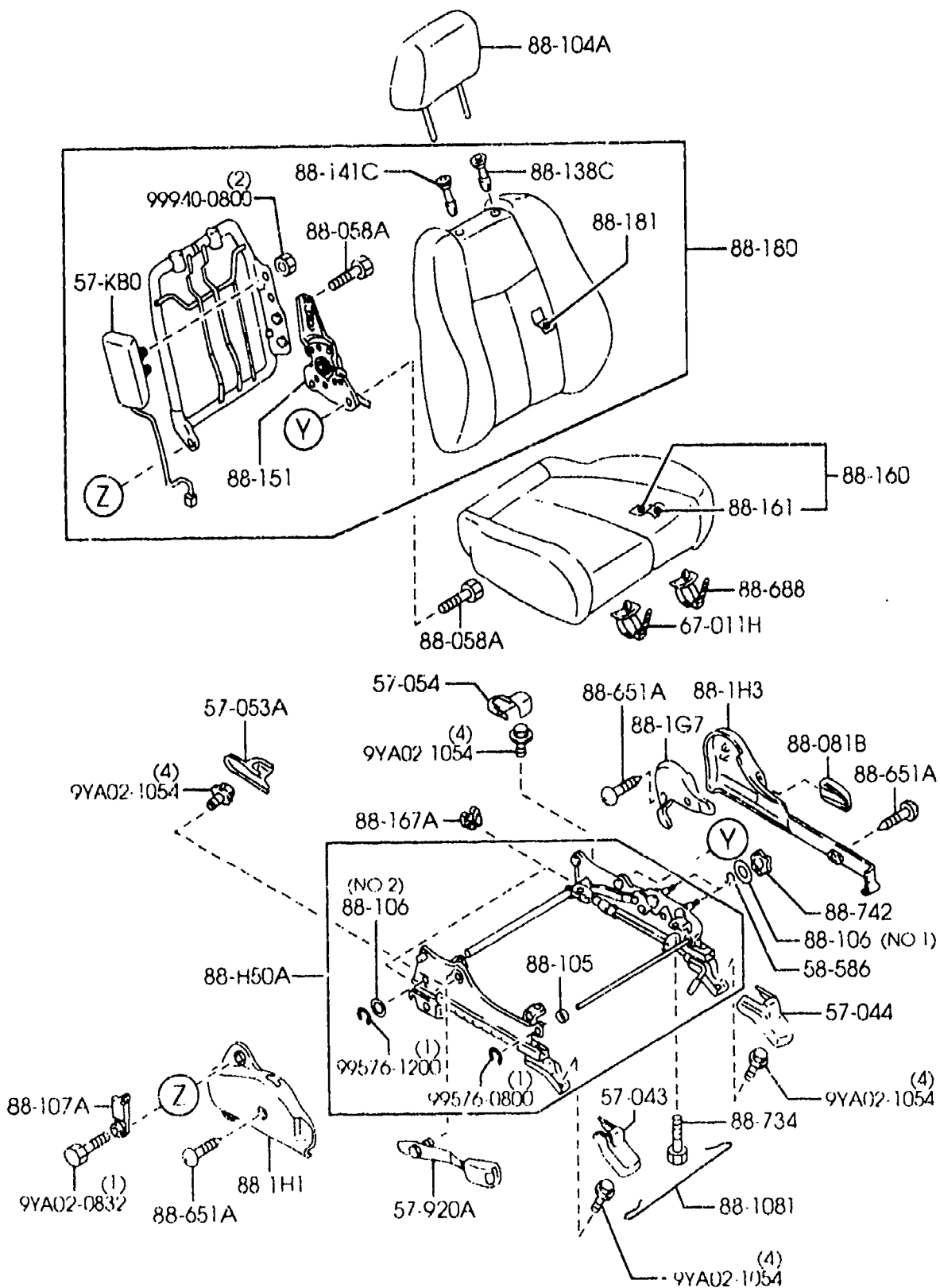

PART NO.	QTY	MODEL/RESTRICTION	MODEL/RESTRICTION	MODEL/RESTRICTION	FROM-10
57-KA0	1	MODULE(R)-A/B,SIDE	MODULE(D)-A/R,LATERA L		-1521
B25D-57-KA0C AN(B25D-57-KA0D)	1	(W/SIDE AIR BAG)			1521-
*B25D-57-KA0D	1	(W/SIDE AIR BAG)			
57-KB0	1	MODULE(L)-A/B,SIDE	MODULE(G)-A/R,LATERA L		-1521
B25D-57-KB0C AN(B25D-57-KB0D)	1	(W/SIDE AIR BAG)			1521-
*B25D-57-KB0D	1	(W/SIDE AIR BAG)			
57-041B	1	COVER NO.1,ADJ-FRT	COUVERCLE NO.1,ADJUS TEUR		
GE4T-57-041B	1				
65	INT-	BN4 OFF-BLACK	BN4 NOIR CLAIR		
57-042	1	COVER NO.2,ADJ-FRT	COUVERCLE NO.2,REGUL .AV.		
GE4T-57-042B	1				
65	INT-	BN4 OFF-BLACK	BN4 NOIR CLAIR		
57-043	1	COVER NO.3,ADJ-FRT	COUV.NO.3,REGUL.-AV		
GE4T-57-043B	1				
65	INT-	BN4 OFF-BLACK	BN4 NOIR CLAIR		
57-044	1	COVER NO.4,ADJ-FRT	COUVERCLE NO.4,ADJUS TEUR		
GE4T-57-044B	1				
65	INT-	BN4 OFF-BLACK	BN4 NOIR CLAIR		
57-051A	1	COVER'A',ADJUSTER-RR	COUVERCLE'A',REGLEUR -AR		
B25D-57-051B	1				
65	INT-	BN4 OFF-BLACK	BN4 NOIR CLAIR		
57-052C	1	COVER'B',ADJUSTER-RR	COUVERCLE'B',REGLEUR -AR		
GE4T-57-052B	1				
65	INT-	BN4 OFF-BLACK	BN4 NOIR CLAIR		
57-053A	1	COVER'C',ADJUSTER-RR	COUVERCLE'C',REGLEUR -AR		
GE4T-57-053B	1				
65	INT-	BN4 OFF-BLACK	BN4 NOIR CLAIR		
57-054	1	COVER'D',ADJUSTER-RR	COUVERCLE'D',REGLEUR -AR		
B25D-57-054B	1				

1521 RJ22\* -475301



(PASSENGER SIDE)

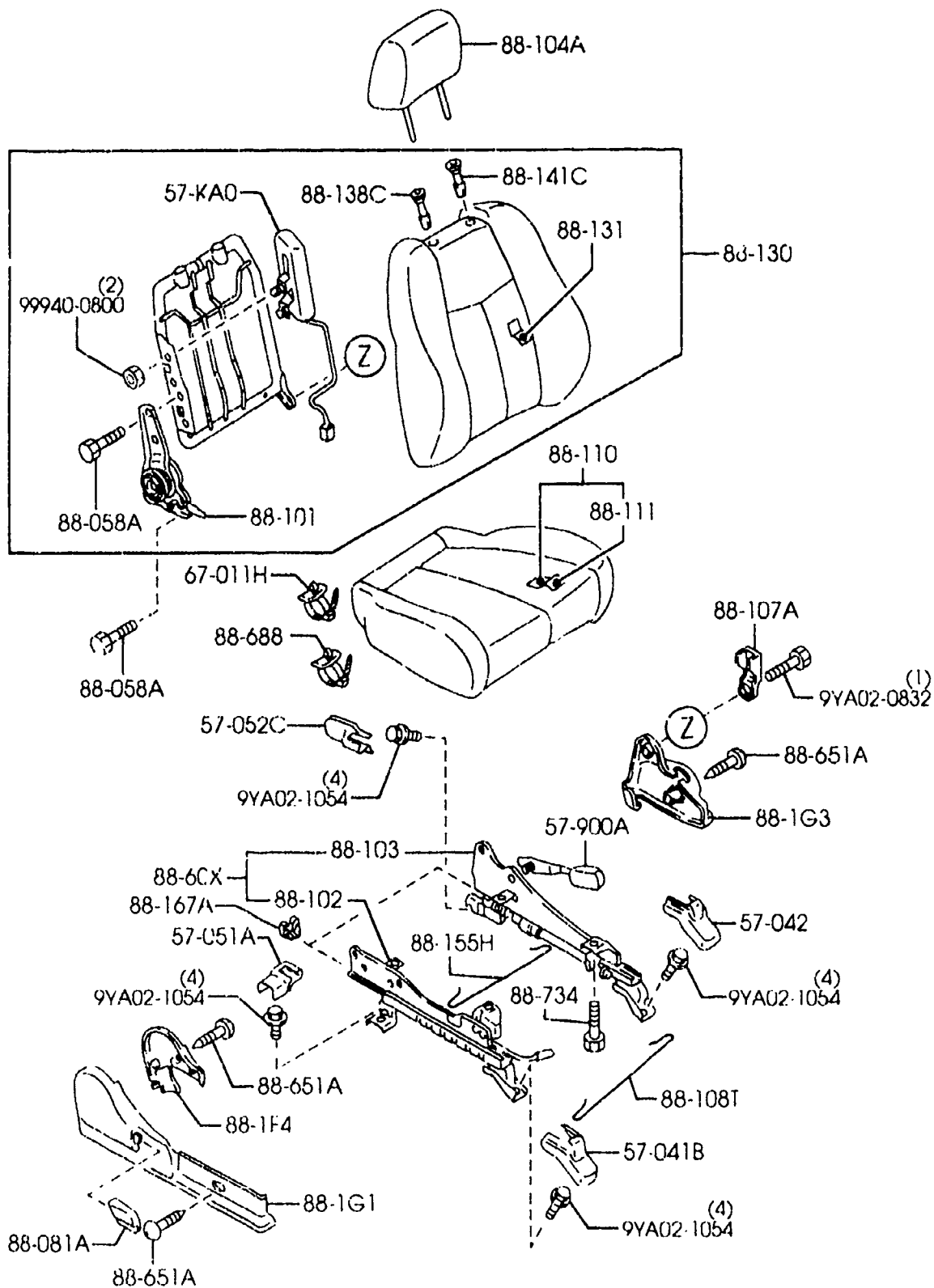

PART NO.	QTY	MODEL/RESTRICTION	MODEL/RESTRICTION	MODEL/RESTRICTION	FROM-TO
CONT'D					
65	INT-	BN4 OFF-BLACK	BN4 NOIR CLAIR		
		+-----+   57-900A   +-----+			
		BELT'A'(R),FRT SEAT	CEINTURE "A"(D)AV.		
B25D-57-680	1				
66	INT-	BN4 BLACK	BN4 NOIR		
		+-----+   57-920A   +-----+			
		BELT'A'(L),FRT SEAT	CEINTURE "A"(G)AV.		
B25D-57-620B	1				
66	INT-	BN4 BLACK	BN4 NOIR		
		+-----+   58-586   +-----+			
		RING,SNAP	BAGUE		
B001-58-585	2				
		+-----+   67-011H   +-----+			
		CLIP	ATTACHE		
H430-67-C91	1	(W/O SIDE AIR BAG)			
H430-67-C91	3	(W/SIDE AIR BAG)			
		+-----+   88-H50A   +-----+			
		LIFT(L),UNIT-FRT	LEVEE(G),ENSEMBLE-AV		
BJ0E-88-H50B	1				
		+-----+   88-058A   +-----+			
		BOLT	BOULON		
LB82-88-061	8				
		+-----+   88-081A   +-----+			
		KNOB(R),KNUCKLE	BOULE(D)		
B25D-88-1G5	1				
65	INT-	BN1 BN4 OFF-BLACK	BN1 BN4 NOIR CLAIR		
		+-----+   88-081B   +-----+			
		KNOB(L),KNUCKLE	BOULE(G)		
B25D-88-1H5	1				
65	INT-	BN1 BN4 OFF-BLACK	BN1 BN4 NOIR CLAIR		
		+-----+   88-1F4   +-----+			
		COVER NO.1,REVERSE	COUVERT. NO.1,INVERS E		
B25D-88-1F4	1				
65	INT-	BN1 BN4 OFF-BLACK	BN1 BN4 NOIR CLAIR		
		+-----+   88-1G1   +-----+			
		COVER NO.1,SIDE-F.SEAT	CACHE NO.1,LAT.-SIEG E AV		
B25D-88-1G1	1				
65	INT-	BN1 BN4 OFF-BLACK	BN1 BN4 NOIR CLAIR		







(PASSENGER SIDE)

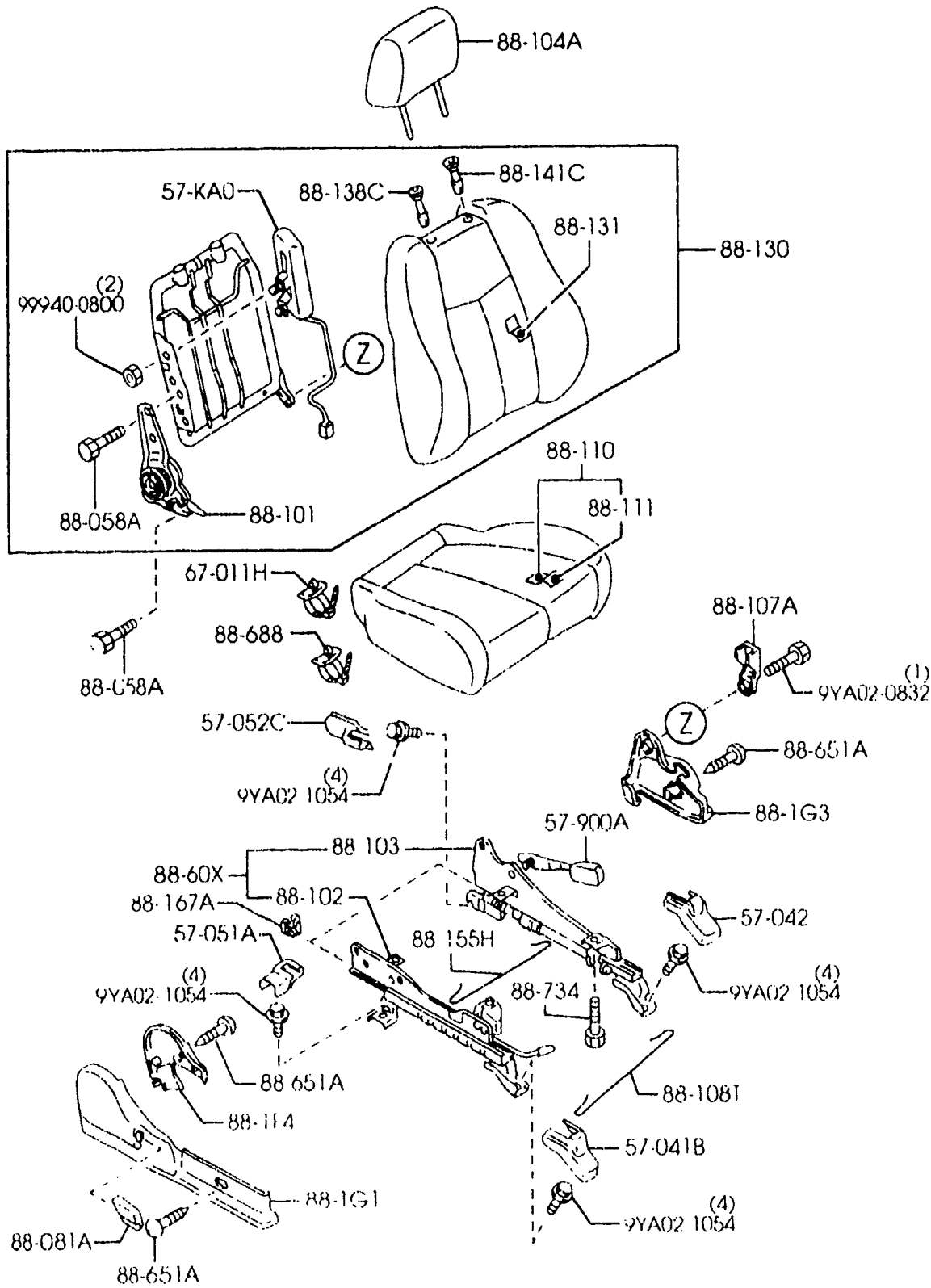

PART NO.	QTY	MODEL/RESTRICTION	MODEL/RESTRICTION	MODEL/RESTRICTION	FROM-TO
88-108T		WIRE, RELEASE	CABLE DE DEGAGEMENT		
B25D-88-026A	2				
88-110		CUSHION(R), FRT SEAT	HOUSSE DE SIEGE (D)		
BL8D-88-110B	1	(W/O SIDE AIR BAG)			
65	INT-	BN4 OFF-BLACK	BN4 NOIR CLAIR		
BL8H-88-110B	1	(W/SIDE AIR BAG)			
65	INT-	BN4 OFF-BLACK	BN4 NOIF CLAIR		
88-111		TRIM(R), SEAT CUSHION	HOUSSE DE SIEGE (D)		
BL8D-88-111	1				
65	INT-	BN4 OFF-BLACK	BN4 NOIR CLAIR		
88-130		BACK(R), FRONT SEAT	SIEGE(D), ARRIERE		
BL8D-88-130	1	(W/O SIDE AIR BAG)			
65	INT-	BN4 OFF-BLACK	BN4 NOIR CLAIR		
BL8H-88-130	1	(W/SIDE AIR BAG)			
65	INT-	BN4 OFF-BLACK	BN4 NOIR CLAIR		-1521
*BL8H-88-130A	1	(W/SIDE AIR BAG)			1521-
*65	INT-	BN4 OFF-BLACK	BN4 NOIR CLAIR		
88-131		TRIM(R), SEAT BACK	GARNITURE (D), SIEGE ARR		
BL8D-88-131	1	(W/O SIDE AIR BAG)			
65	INT-	BN4 OFF-BLACK	BN4 NOIR CLAIR		
BL8H-88-131	1	(W/SIDE AIR BAG)			
65	INT-	BN4 OFF-BLACK	BN4 NOIR CLAIR		
88-138C		GUIDE, POLE-NO.2	GUIDE, MAT NO 2		
B25D-88-1G9A	2				
65	INT-	BN1 BN4 OFF-BLACK	BN1 BN4 NOIR CLAIR		
88-141C		GUIDE, POLE-NO.1	GUIDE, MAT NO 1		
B25D-88-1G8A	2				
65	INT-	BN1 BN4 OFF-BLACK	BN1 BN4 NOIR CLAIR		
88-151		KNUCKLE(L), RECLINING	CHARNIERE D'INCLINAI		
B25D-88-155	1		SON (		

1521 BJ22\* -475301

(DRIVER SIDE)

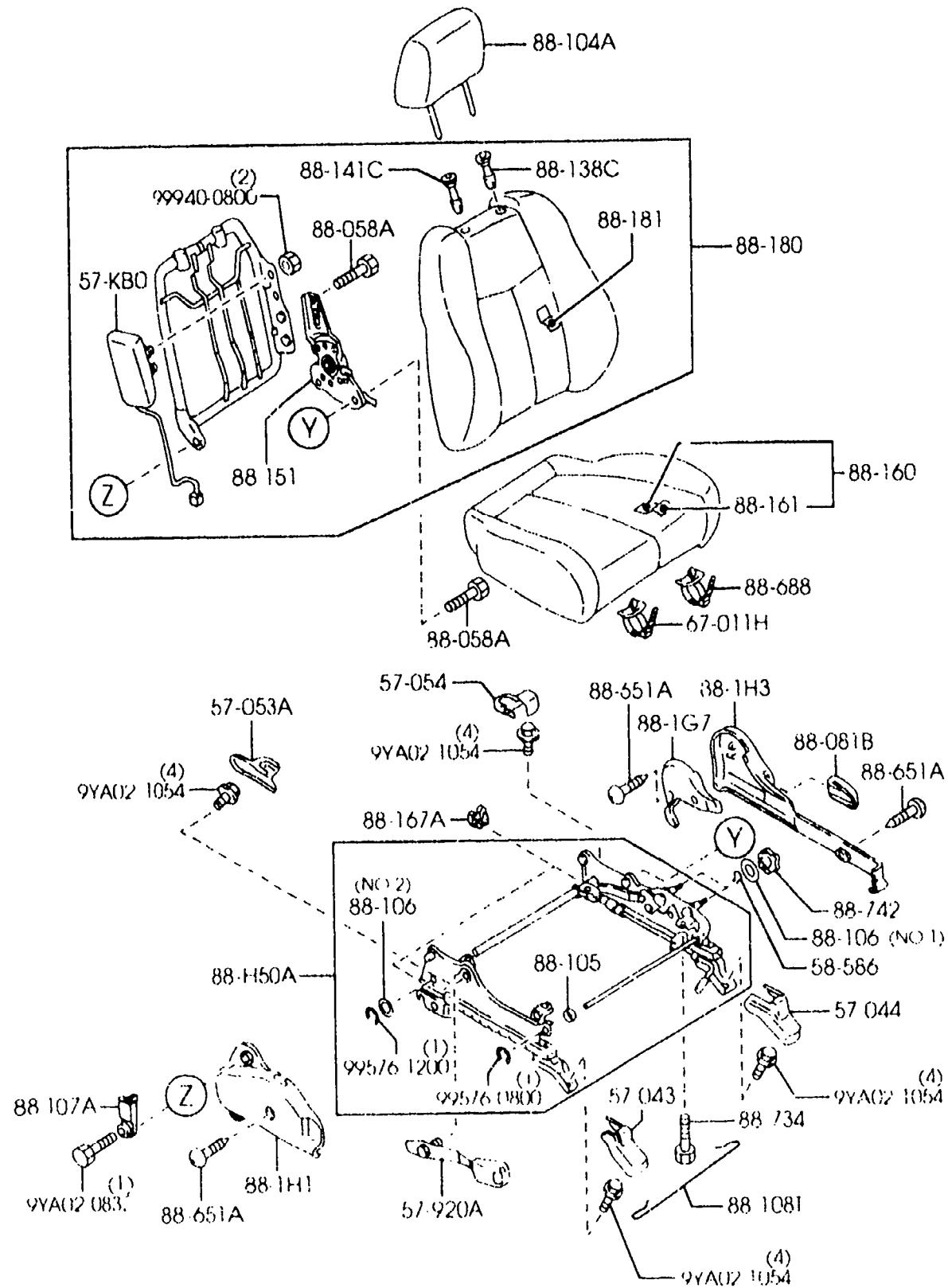

PART NO.	QTY	MODEL/RESTRICTION	MODEL/RESTRICTION	MODEL/RESTRICTION	FROM-TO
88-155H		WIRE, SUPORTING	FIL METALLIQUE, SUPPO RT		
B25D-08-029	1				
88-160		CUSHION(L), FRT SEAT	HOUSSE DE SIEGE (G)		
BL8D-88-160B	1	(W/O SIDE AIR BAG)			
65	INT-	BN4 OFF-BLACK	BN4 NOIR CLAIR		
BL8H-88-160B	1	(W/SIDE AIR BAG)			
65	INT-	BN4 OFF-BLACK	BN4 NOIR CLAIR		
88-161		TRIM(L), SEAT CUSHION	HOUSSE DE SIEGE (G)		
BL8D-88-161	1	(W/O SIDE AIR BAG)			
65	INT-	BN4 OFF-BLACK	BN4 NOIR CLAIR		
BL8H-88-161	1	(W/SIDE AIR BAG)			
65	INT-	BN4 OFF-BLACK	BN4 NOIR CLAIR		
88-167A		PROTECTOR	PROTECTEUR		
B25D-88-091	4				
88-180		BACK(L), FRONT SEAT	SIEGE(G), ARRIERE		
BL8D-88-180	1	(W/O SIDE AIR BAG)			
65	INT-	BN4 OFF-BLACK	BN4 NOIR CLAIR		-1521
BL8H-88-180	1	(W/SIDE AIR BAG)			
65	INT-	BN4 OFF-BLACK	BN4 NOIR CLAIR		
*BL8H-88-180A	1	(W/SIDE AIR BAG)			1521-
* 65	INT-	BN4 OFF-BLACK	BN4 NOIR CLAIR		
88-181		TRIM(L), SEAT BACK	HOUSSE (G), SIEGE AR		
BL8D-88-181	1	(W/O SIDE AIR BAG)			
65	INT-	BN4 OFF-BLACK	BN4 NOIR CLAIR		
BL8H-88-181	1	(W/SIDE AIR BAG)			
65	INT-	BN4 OFF-BLACK	BN4 NOIR CLAIR		
88-60X		ADJUSTER UNIT(R), FRT SEAT	DISP. REGLEUR(D), SIE GE AV		
B25D-88-A00B	1				
88-651A		SCREW, TAPPING	MEMBRURE, VERTICALE		
G211-88-651	8				

1521 BJ22\* -475301



(PASSENGER SIDE)

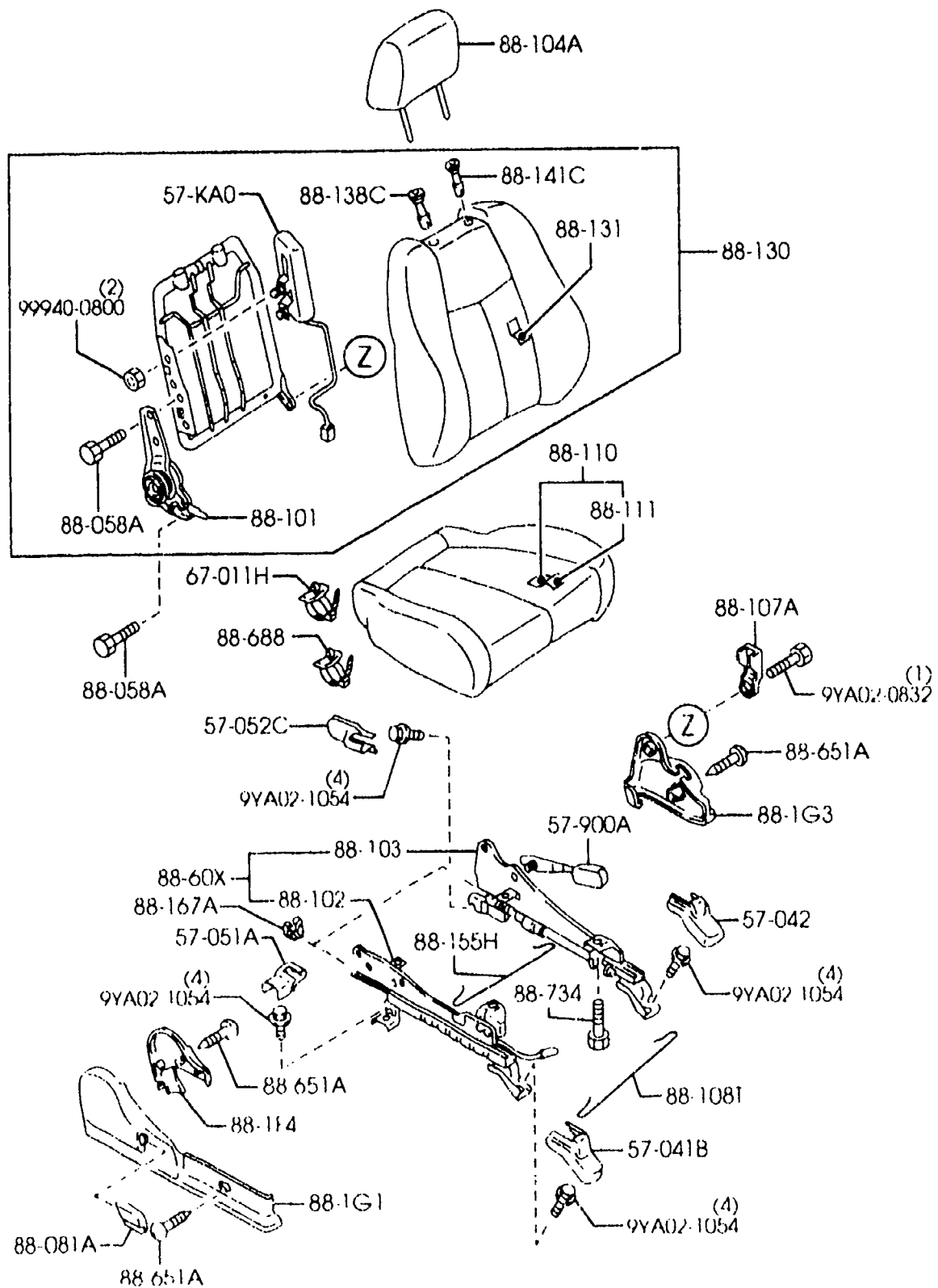

PART NO.	QTY	MODEL/RESTRICTION	MODEL/RESTRICTION	MODEL/RESTRICTION	FROM-TO
88-688		CLIP	ATTACHE		
B25F-88-126	2	(W/SIDE AIR BAG)			
88-734		BOLT	BOULON		
B092-88-818	8				
88-742		DIAL,SUPPORT	BOULTON		
GE4T-88-1L1	2				
65	INT-	BN1 BN4 OFF-BLACK	BN1 BN4 NOIR CLAIR		

(STA TYPE) (STF TYPE)  
(STB TYPE) (STG TYPE)  
(STE TYPE)

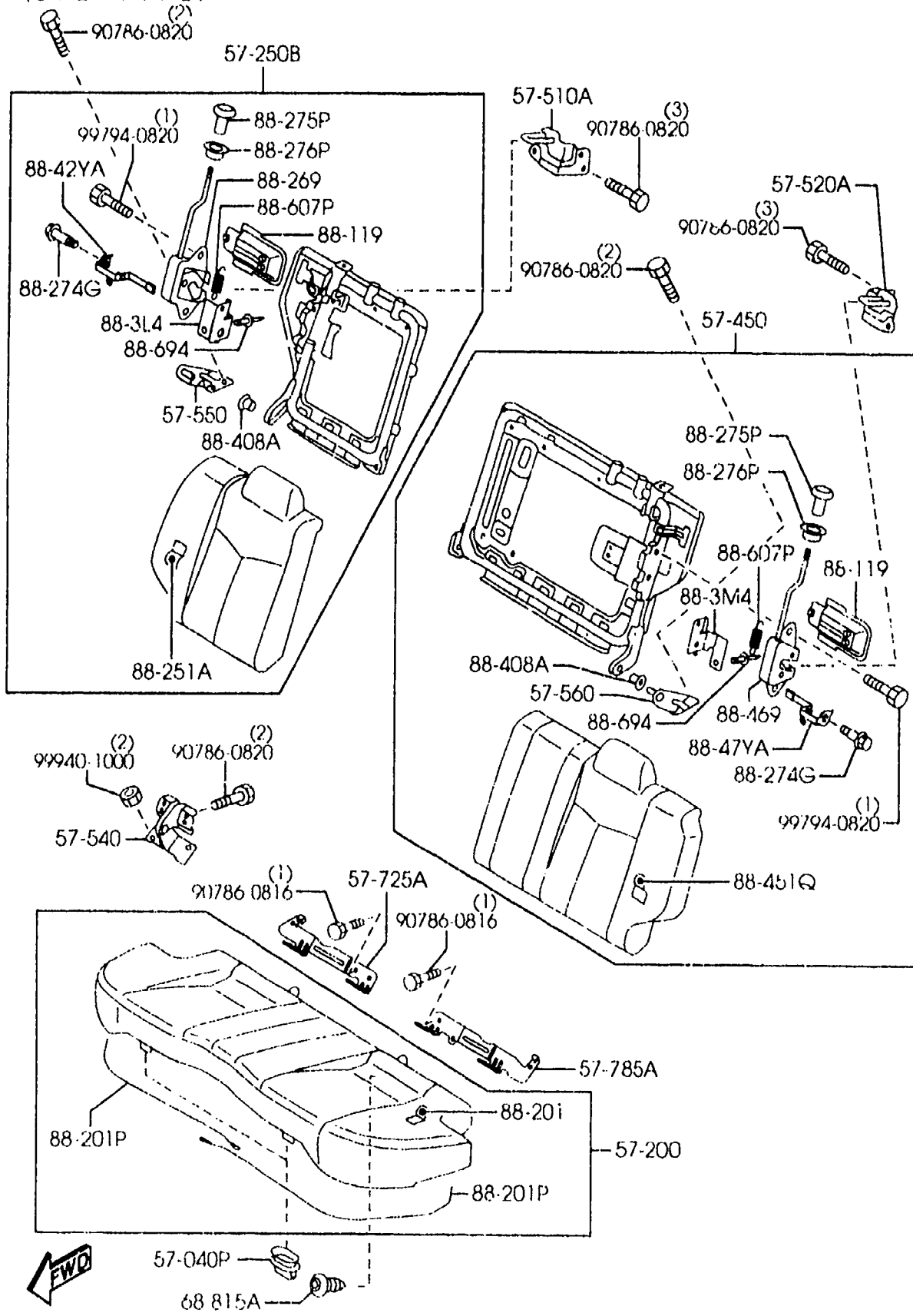

(STD TYPE)

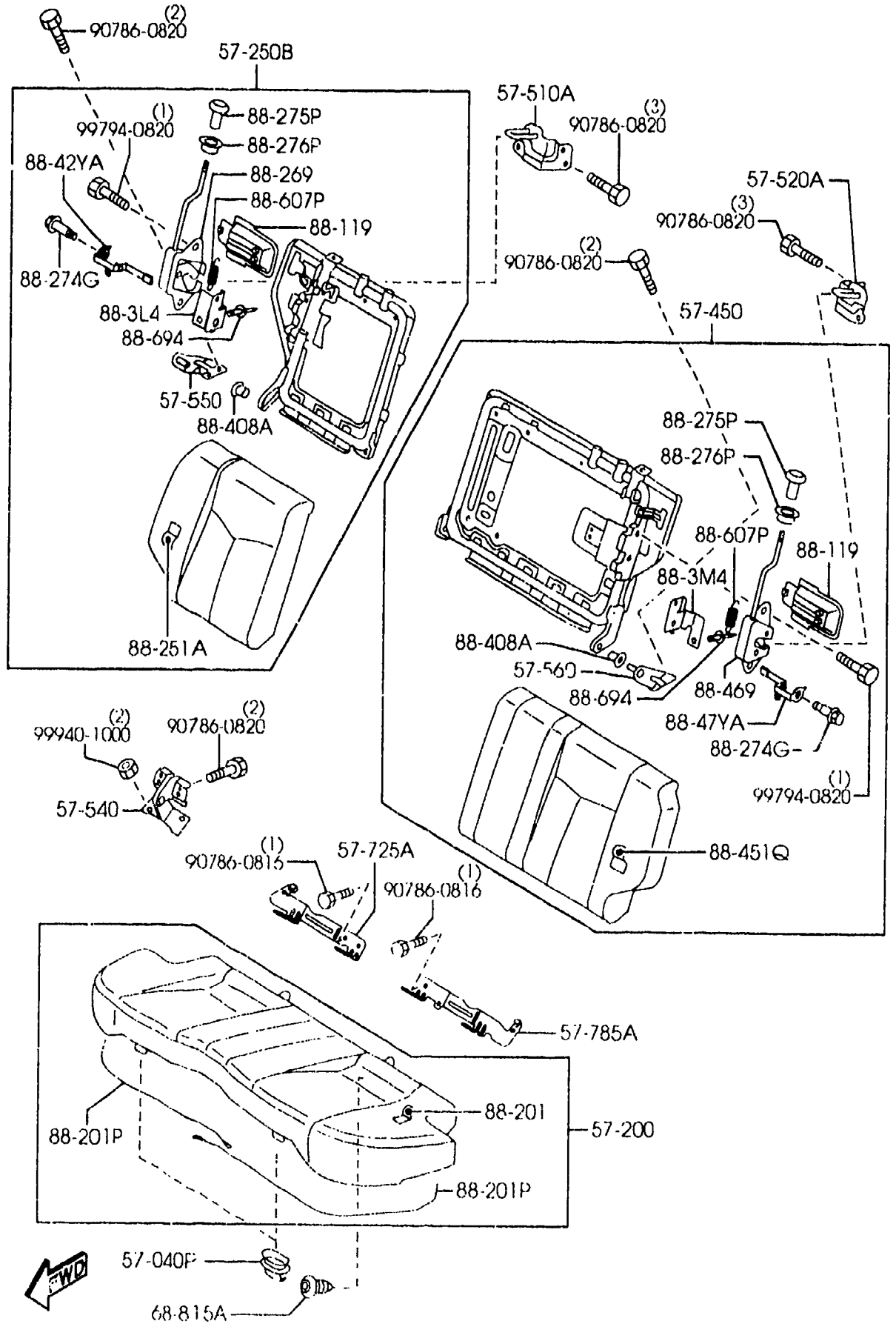

(STC TYPE)

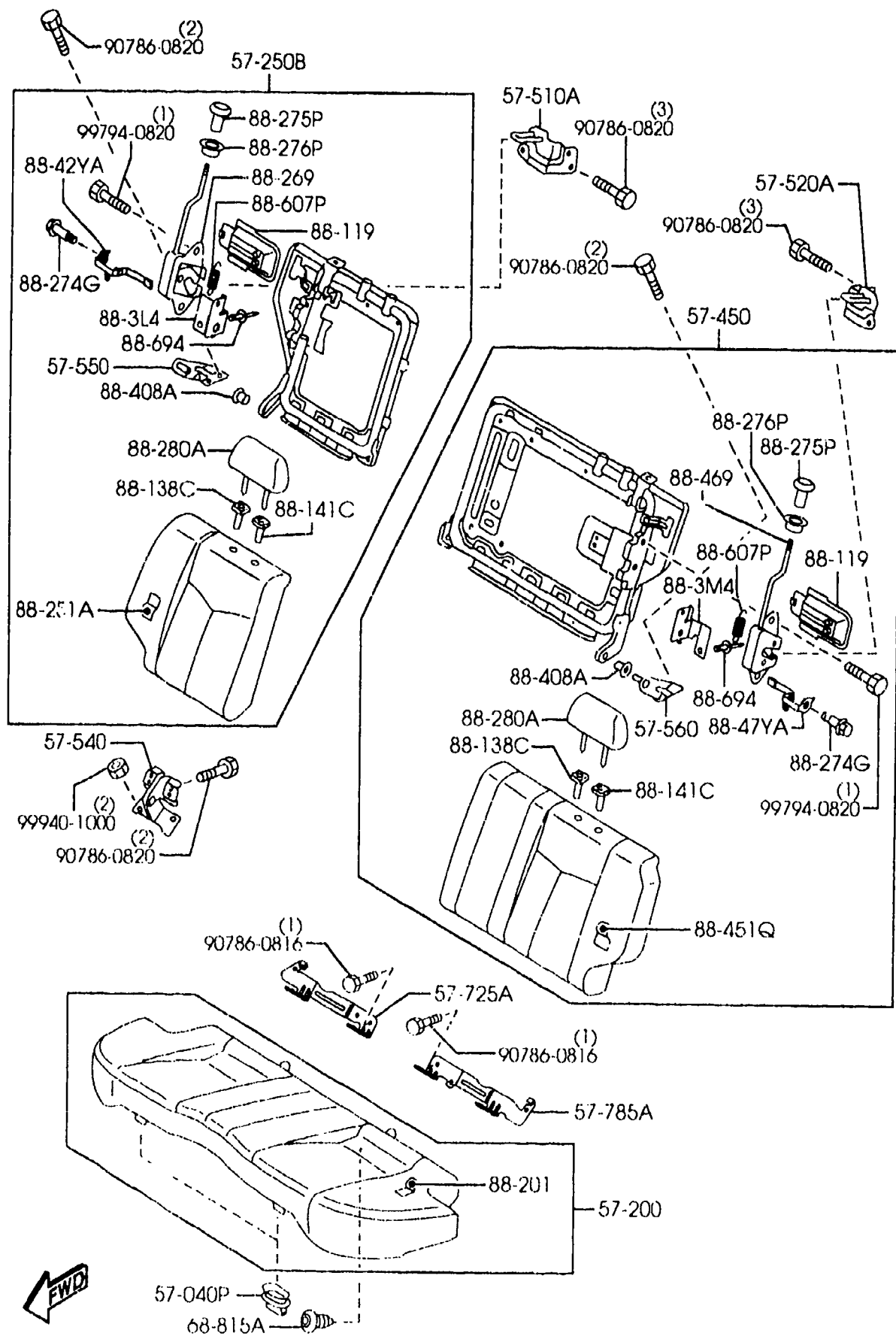

5750A REAR SEATS  
(4-DOOR)

(1/3)

(STA TYPE) (STF TYPE)  
(STB TYPE) (STG TYPE)  
(STE TYPE)

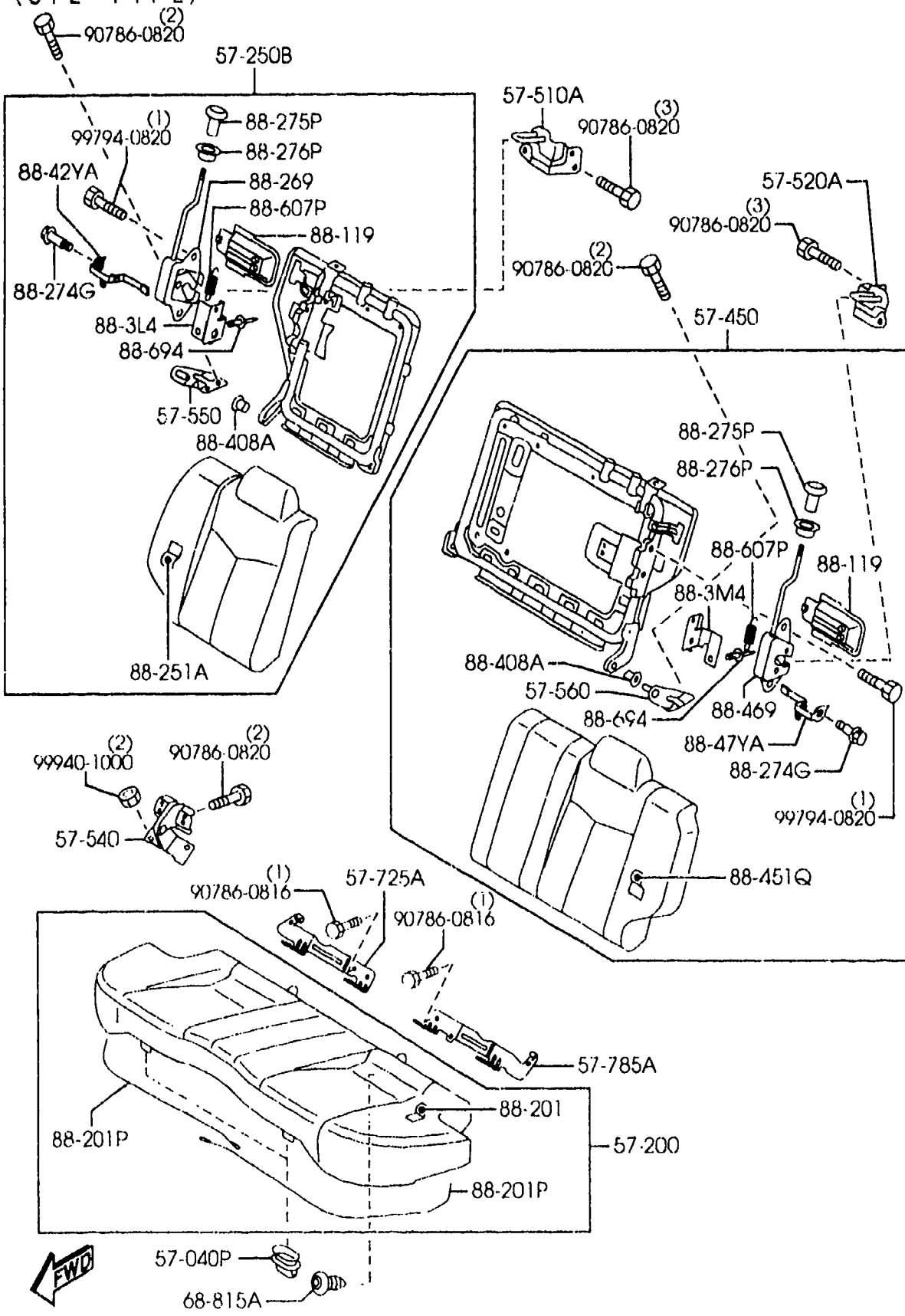

5750A -1 REAR SEATS  
(4-DOOR)

PART NO.	QTY	MODEL/RESTRICTION	MODEL/RESTRICTION	MODEL/RESTRICTION	FROM-TO
57-040P		LOCK,RR. SEAT CUSHION	BLOCAGE,COUSSIN DE N		
G04P-57-529	2				
57-200		CUSHION,REAR SEAT	COUSSIN,SIEGE AR		
BL8F-57-200	1	(STD TYPE) (STG TYPE)			
05	INT-	BN2 DARK GRAY	BN2 GRIS FONCE		
80	INT-	BN3 BEIGE	BN3 BEIGE		
BN7H-57-200	1	(STF TYPE)			
65	INT-	BN4 BLACK/OFF-BLACK	BN4 NOIR/NOIR CLAIR		
B30D-57-200	1	(STA TYPE)			
65	INT-	BN4 OFF-BLACK	BN4 NOIR CLAIR		
B30S-57-200	1	(STB TYPE) (STC TYPE) (STE TYPE)			
65	INT-	BN1 DARK GRAY	BN1 GRIS FONCE		
80	INT-	BN3 BEIGE	BN3 BEIGE		
57-250B		BACK(R),REAR SEAT	SIEGE D ARR.		
BL8D-57-400A	1	(STA TYPE)			-1701
65	INT-	BN4 OFF-BLACK	BN4 NOIR CLAIR		
BL8C-57-400A	1	(STB TYPE) (STE TYPE)			-1701
65	INT-	BN1 DARK GRAY	BN1 GRIS FONCE		
80	INT-	BN3 BEIGE	BN3 BEIGE		
BL8F-57-400A	1	(STD TYPE)			-1701
05	INT-	BN2 GRAY	BN2 GRIS		
80	INT-	BN3 BEIGE	BN3 BEIGE		
BL9J-57-400A	1	(STC TYPE)			-1701
65	INT-	BN1 DARK GRAY	BN1 GRIS FONCE		
80	INT-	BN3 BEIGE	BN3 BEIGE		
BN7H-57-400	1	(STF TYPE)			-1701
65	INT-	BN4 BLACK/OFF-BLACK	BN4 NOIR/NOIR CLAIR		
*BL4P-57-400B	1	(STG TYPE)			1701-
* 05	INT-	BN2 DARK GRAY	BN2 GRIS FONCE		
* 80	INT-	BN3 BEIGE	BN3 BEIGE		
*BL8D-57-400b	1	(STA TYPE)			1701-

1701 BJ22\* 493151

AUBA09

(2B66671)

CAR. AUBA09-02

2001-07

3-K15

5750A REAR SEATS  
(4-DOOR)

(2/3)

(STD TYPE)

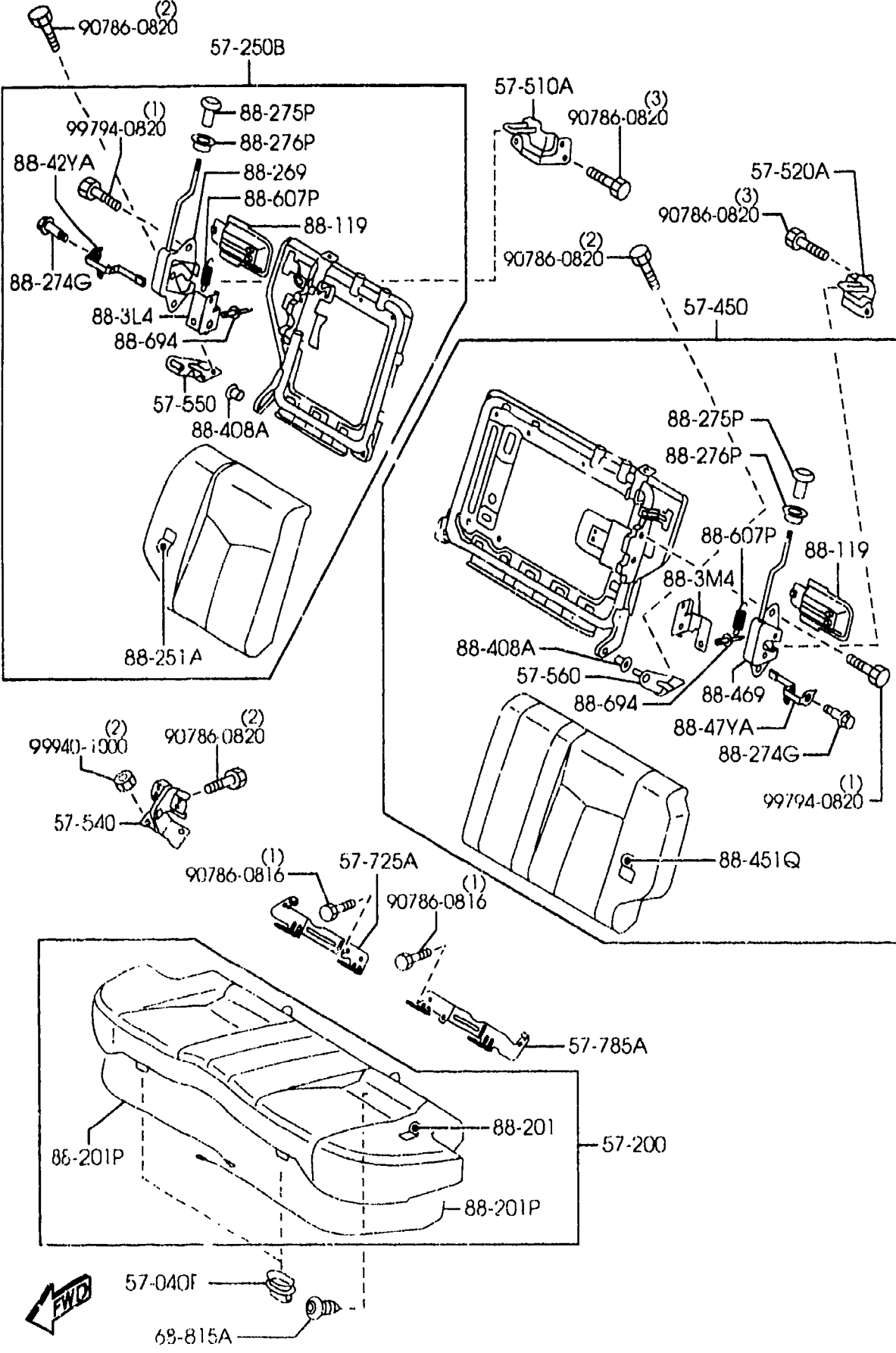

AUJBA09

(2B66672)

5750A -2 REAR SEATS  
(4-DOOR)

PART NO.	QTY	MODEL/RESTRICTION	MODEL/RESTRICTION	MODEL/RESTRICTION	FROM-TO
CONT'D					
* 65	INT-	BN4 OFF-BLACK	BN4 NOIR CLAIR		
*BL8E-57-400B	1	(STB TYPE) (STE TYPE)			1701-
* 65	INT-	BN1 DARK GRAY	BN1 GRIS FONCE		
* 80	INT-	BN3 BEIGE	BN3 BEIGE		
*BL8F-57-400B	1	(STD TYPE)			1701-
* 05	INT-	BN2 GRAY	BN2 GRIS		
* 80	INT-	BN3 BEIGE	BN3 BEIGE		
*BL9J-57-400B	1	(STC TYPE)			1701-
* 65	INT-	BN1 DARK GRAY	BN1 GRIS FONCE		
* 80	INT-	BN3 BEIGE	BN3 BEIGE		
*BN7H-57-400A	1	(STF TYPE)			1701-
* 65	INT-	BN4 BLACK/OFF-BLACK	BN4 NOIR/NOIR CLAIR		
57-450		BACK(L), REAR SEAT	SIEGE G ARR.		
BL8D-57-450A	1	(STA TYPE)			-1701
65	INT-	BN4 OFF-BLACK	BN4 NOIR CLAIR		
BL8E-57-450A	1	(STB TYPE) (STE TYPE)			-1701
65	INT-	BN1 DARK GRAY	BN1 GRIS FONCE		
80	INT-	BN3 BEIGE	BN3 BEIGE		
BL8F-57-450A	1	(STD TYPE)			-1701
05	INT-	BN2 GRAY	BN2 GRIS		
80	INT-	BN3 BEIGE	BN3 BEIGE		
BL9J-57-450A	1	(STC TYPE)			-1701
65	INT-	BN1 DARK GRAY	BN1 GRIS FONCE		
80	INT-	BN3 BEIGE	BN3 BEIGE		
BN7H-57-450	1	(STF TYPE)			-1701
65	INT-	BN4 BLACK/OFF-BLACK	BN4 NOIR/NOIR CLAIR		
*BL4P-57-450B	1	(STG TYPE)			1701-
* 05	INT-	BN2 DARK GRAY	BN2 GRIS FONCE		
* 80	INT-	BN3 BEIGE	BN3 BEIGE		
*BL8D-57-450B	1	(STA TYPE)			1701-
* 65	INT-	BN4 OFF-BLACK	BN4 NOIR CLAIR		
*BL8E-57-450B	1	(STB TYPE) (STE TYPE)			1701-
1701 BJ22* -493151					

CAT. AUBA09-02

2001-07

3-L15



(STC TYPE)

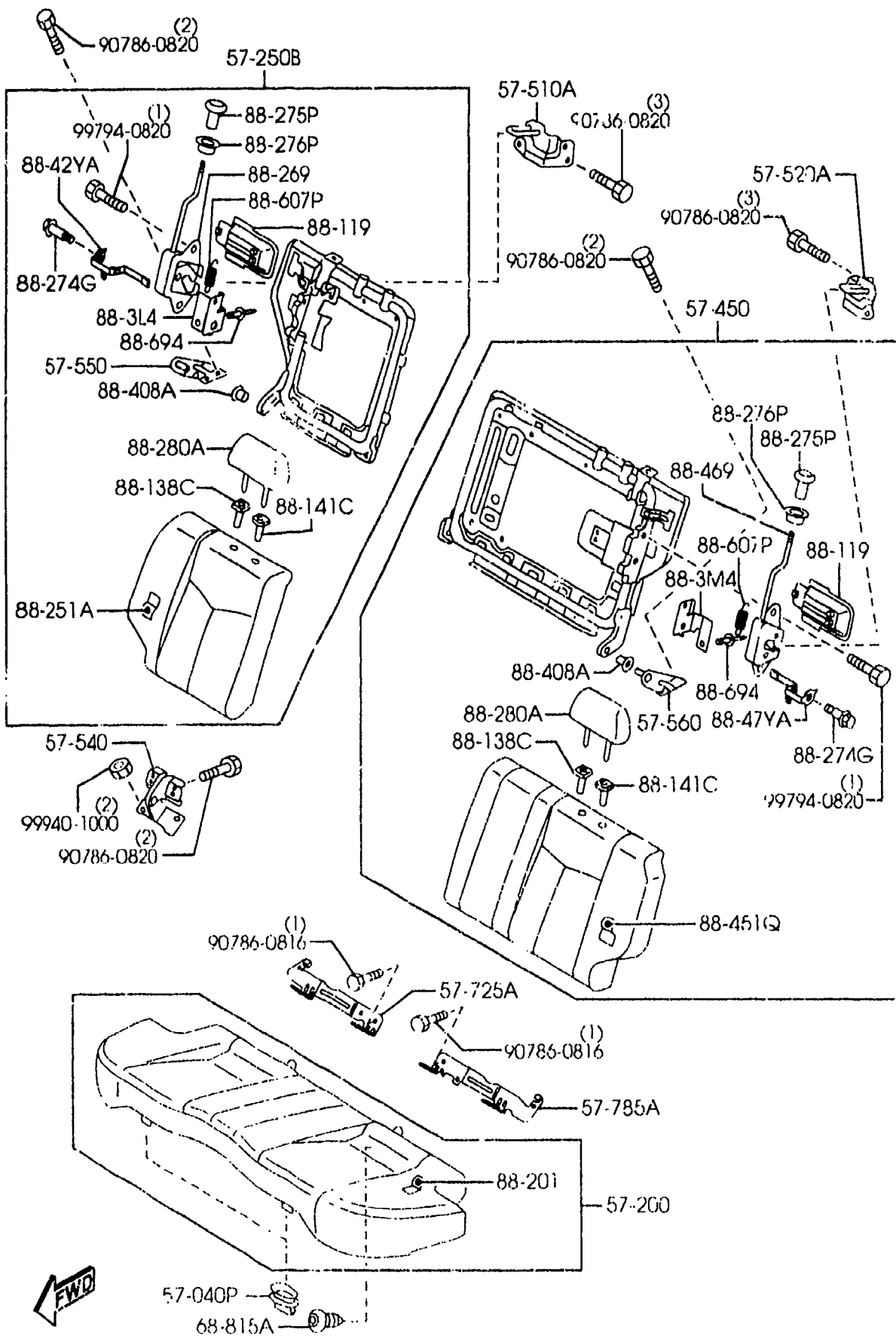

PART NO.	QTY	MODEL/RESTRICTION	MODEL/RESTRICTION	MODEL/RESTRICTION	FRM-TO
CONT'D					
* 65	INT-	BN1 DARK GRAY	BN1 GRIS FONCE		
* 80	INT-	BN3 BEIGE	BN3 BEIGE		
*BL8F-57-450B	1	(STD TYPE)			1701-
* 05	INT-	BN2 GRAY	BN2 GRIS		
* 80	INT-	BN3 BEIGE	BN3 BEIGE		
*BL9J-57-450B	1	(STC TYPE)			1701-
* 65	INT-	BN1 DARK GRAY	BN1 GRIS FONCE		
* 80	INT-	BN3 BEIGE	BN3 BEIGE		
*BN7H-57-450A	1	(STF TYPE)			1701-
* 65	INT-	BN4 BLACK/OFF-BLACK	BN4 NOIR/NOIR CLAIR		
57-510A	1	STRIKER(R),RR BACK	GACHE(D)		
B25E-57-510	1				
57-520A	1	STRIKER(L),RR BACK	GACHE(G)		
B25E-57-520	1				
57-540	1	HINGE,CENTER-RR BACK	CHARNIERE,CENTRE-POS .SIEG		
B25E-57-540A	1				
57-550	1	HINGE(R),REAR BACK	CHARNIERE(D),DOSSIER		
B30D-88-40Y	1				
57-560	1	HINGE(L),REAR BACK	CHARNIERE(G),DOSSIER		
B30D-88-45Y	1				
57-725A	1	ANCHOR-CHILD SEAT,LW R	ANCR.SIEGE D'ENFANT INFE		-0C01
B30D-57-725C AN(B30D-57-725D)	1				
B30D-57-725D	1				0C01-
57-785A	1	ANCHOR-CHILD SEAT,LW R	ANCR.SIEGE D'ENFANT I NFE		-0C01
B30D-57-785C AN(B30D-57-785D)	1				
B30D-57-785D	1				0C01-
68-815A	2	TACKER	ATTACHE		
1011-68-815	2				

0C01 BJ22\* -406227  
1701 BJ22\* -493151

5750A REAR SEATS  
(4-DOOR)

(1/3)

(STA TYPE) (STF TYPE)  
(STB TYPE) (STG TYPE)  
(STE TYPE)

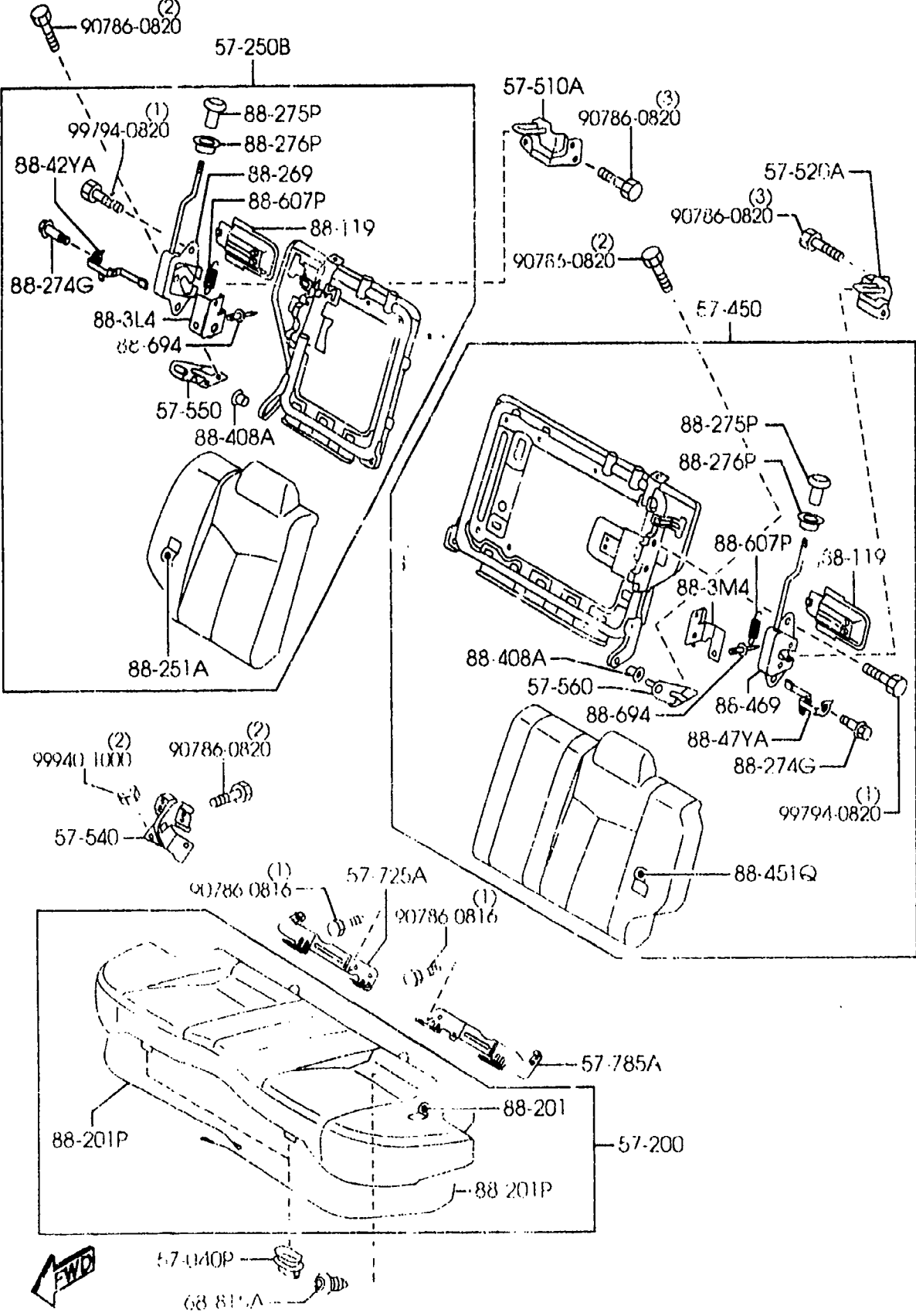

5750A -4 REAR SEATS  
(4-DOOR)

PART NO.	QTY	MODEL/RESTRICTION	MODEL/RESTRICTION	MODEL/RESTRICTION	FROM-TO
88-119		COVER, LEVER	COUVERCLE, LEVIER		
BJ1V-88-4E3	2				
88-138C		GUIDE, POLE-NO.2	GUIDE, MAT NO 2		
B25D-98-169A	2 (STC TYPE)				
05	INT-	BN2 GRAY	BN2 GRIS		
65	INT-	BN1 BN4 OFF-BLACK	BN1 BN4 NOIR CLAIR		
80	INT-	BN3 BEIGE	BN3 BEIGE		
88-141C		GUIDE, POLE-NO.1	GUIDE, MAT NO 1		
B25D-88-168A	2 (STC TYPE)				
05	INT-	BN2 GRAY	BN2 GRIS		
65	INT-	BN1 BN4 OFF-BLACK	BN1 BN4 NOIR CLAIR		
80	INT-	BN3 BEIGE	BN3 BEIGE		
88-201		TRIM, RR SEAT CUSHION	GARNITURE, COUSSIN DE SIEG		
BL8F-88-201	1 (STD TYPE) (STG TYPE)				
05	INT-	BN2 GRAY	BN2 GRIS		
80	INT-	BN3 BEIGE	BN3 BEIGE		
BN7H-88-201	1 (STF TYPE)				
65	INT-	BN4 BLACK/OFF-BLACK	BN4 NOIR/NOIR CLAIR		
B30D-88-201	1 (STA TYPE)				
65	INT-	BN4 OFF-BLACK	BN4 NOIR CLAIR		
B30S-88-201	1 (STB TYPE) (STC TYPE) (STE TYPE)				
65	INT-	BN1 DARK GRAY/GRAY	BN1 GRIS FONCE/GRIS		
80	INT-	BN3 BEIGE	BN3 BEIGE		
88-201P		TRIM, REAR SEAT CUSHION	GARNITURE,		
B30D-88-221	2 (STD TYPE) (STG TYPE)				
88-251A		TRIM(R), RR SEAT BACK	GARNITURE, DOSSIER AR (G)		
BL8D-88-401	1 (STA TYPE)				
65	INT-	BN4 OFF-BLACK	BN4 NOIR CLAIR		
BL8E-88-401	1 (STB TYPE) (STE TYPE)				

AUBA09

(2B66671)

CAT. AUBA09-02

2001-07

3-N15

(STD TYPE)

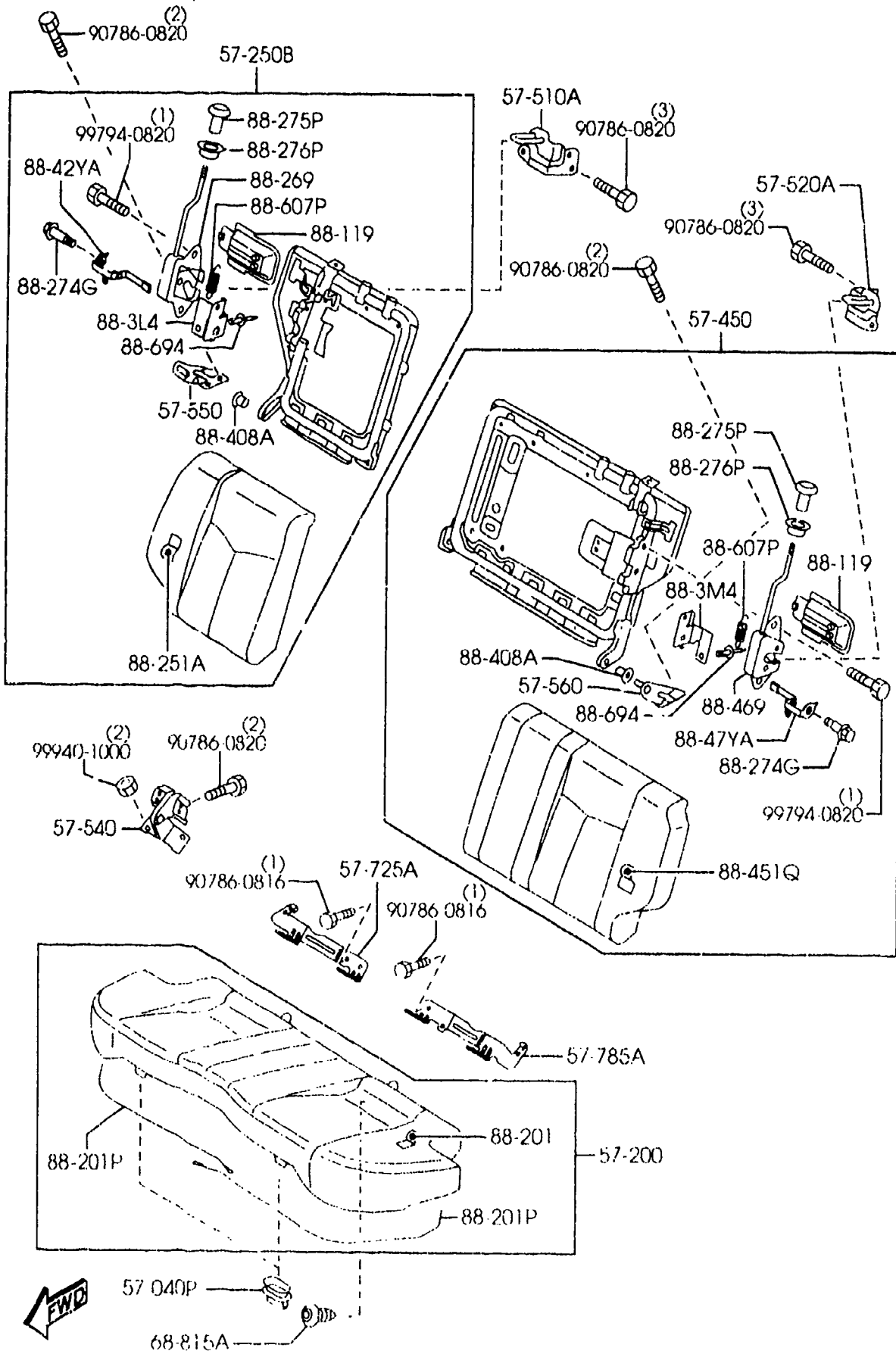

PART NO.	QTY	MODEL/RESTRICTION	MODEL/RESTRICTION	MODEL/RESTRICTION	FROM 10
CONT'D					
65	INT-	BN1 DARK GRAY/GRAY	BN1 GRIS FONCE/GRIS		
80	INT-	BN3 BEIGE	BN3 BEIGE		
BL8F-88-401	1	(STD TYPE)			
05	INT-	BN2 GRAY	BN2 GRIS		
80	INT-	BN3 BEIGE	BN3 BEIGE		
BL9J-88-401	1	(STC TYPE)			
65	INT-	BN1 DARK GRAY/GRAY	BN1 GRIS FONCE/GRIS		
80	INT-	BN3 BEIGE	BN3 BEIGE		
BN7H-88-401	1	(STF TYPE)			
65	INT-	BN4 BLACK/OFF-BLACK	BN4 NOIR/NOIR CLAIR		
*PL4P-88-401	1	(STG TYPE)			1701-
* 05	INT-	BN2 GRAY	BN2 GRIS		
* 80	INT-	BN3 BEIGE	BN3 BEIGE		
+-----+   88-269   +-----+		CATCH(R),RR SEAT BACK	ATTACHE(D),DOSSIER A R		
B25E-88-420A	1				
+-----+   88-274G   +-----+		PIN,ARM REST	CLAVETTE,APUI BRAS		
BJ1V-88-3A6	2				
+-----+   88-275P   +-----+		KNOB,REAR SEAT BACK	BOUTON,		
B006-88-275	2				
05	INT-	BN2 GRAY	BN2 GRIS		
65	INT-	BN1 BN4 OFF-BLACK	BN1 BN4 NOIR CLAIR		
80	INT-	BN3 BEIGE	BN3 BEIGE		
+-----+   88-276P   +-----+		BUSH,REAR SEAT BACK	BALAIS		
B006-88-276	2				
05	INT-	BN2 GRAY	BN2 GRIS		
65	INT-	BN1 BN4 OFF-BLACK	BN1 BN4 NOIR CLAIR		
80	INT-	BN3 BEIGE	BN3 BEIGE		
+-----+   88-280A   +-----+		RESTRAINT,HEAD	REPOSE-TETE		
BL9J-88-240	2	(STC TYPE)			
65	INT-	BN1 DARK GRAY/GRAY	BN1 GRIS FONCE/GRIS		
80	INT-	BN3 BEIGE	BN3 BEIGE		

1701 BJ22\* -493151

(STC TYPE)

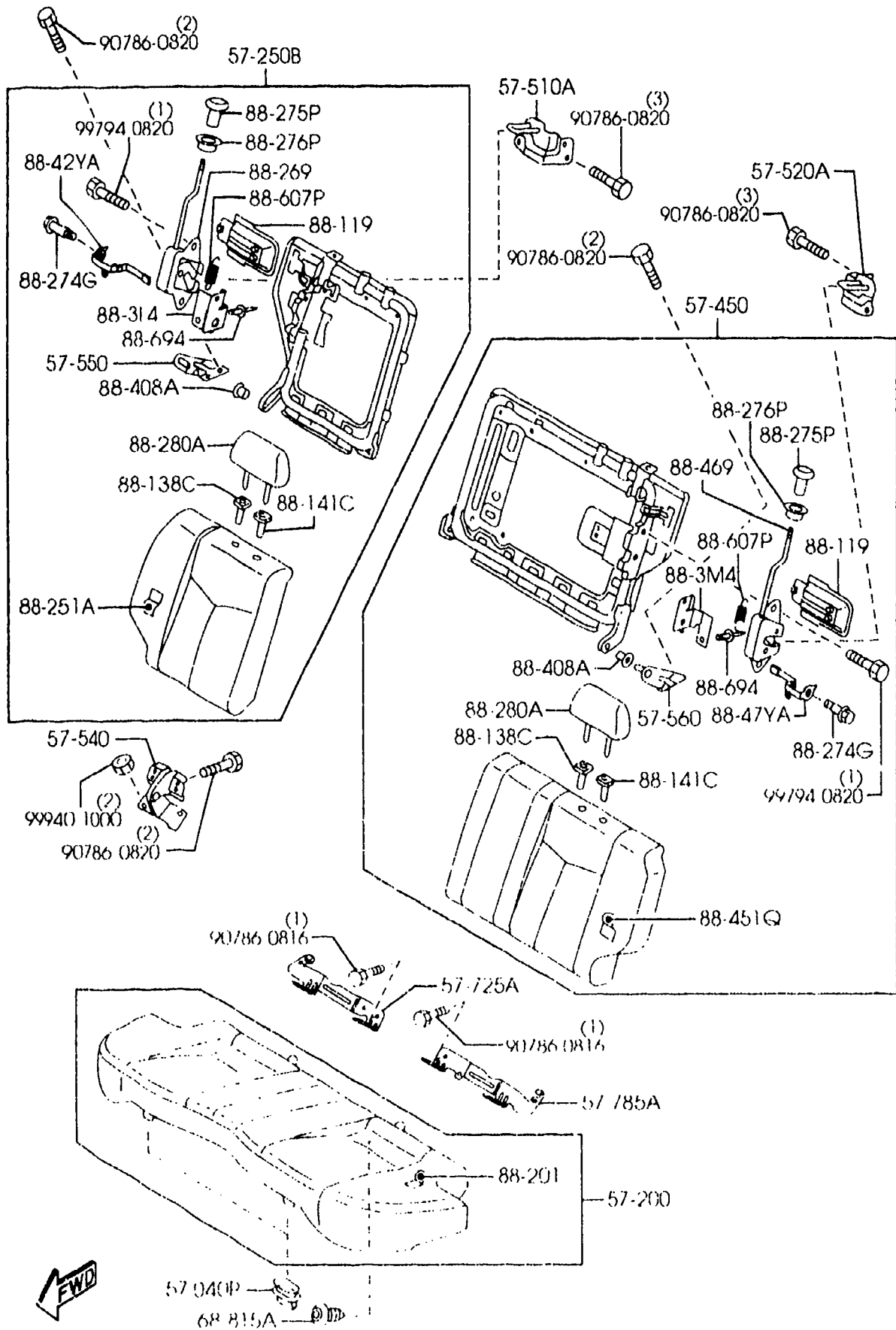

PART NO.	QTY	MODEL/RESTRICTION	MODEL/RESTRICTION	MODEL/RESTRICTION	FROM-10
88-3L4 BJ1V-88-3L4	1	PLATE(R), SET-RR SEAT BACK	PLAQUE(D), JEU-DOSS. SIE. AR		
88-3M4 BJ1V-88-3M4	1	PLATE(L), SET-RR SEAT BACK	PLAQUE(G), JEU-DOSS. SIE. AR		
88-408A B458-88-408	2	BUSHING, HINGE	DOUILLE, CHARNIERE		
88-42YA BJ1V-88-42Y	1	LINK(R), RR SEAT BACK	BIELLE(D), DOSS. SIEGE AR		
88-451Q BL8D-88-451	1	TRIM(L), RR SEAT BACK (STA TYPE)	HOUSSE G DOSSIER ARR		
65	INT-	BN4 OFF-BLACK	BN4 NOIR CLAIR		
88-451 BL8E-88-451	1	(STB TYPE) (STE TYPE)			
65	INT-	BN1 DARK GRAY/GRAY	BN1 GRIS FONCE/GRIS		
80	INT-	BN3 BEIGE	BN3 BEIGE		
88-451 BL8F-88-451	1	(STD TYPE)			
05	INT-	BN2 GRAY	BN2 GRIS		
80	INT-	BN3 BEIGE	BN3 BEIGE		
88-451 BL9J-88-451	1	(STC TYPE)			
65	INT-	BN1 DARK GRAY/GR/	BN1 GRIS FONCE/GRIS		
80	INT-	BN3 BEIGE	BN3 BEIGE		
88-451 BN7H-88-451	1	(STF TYPE)			
65	INT-	BN4 BLACK/OFF-BLACK	BN4 NOIR/NOIR CLAIR		
88-451 *BL4P-88-451	1	(STG TYPE)			1701-
* 05	INT-	BN2 GRAY	BN2 GRIS		
* 80	INT-	BN3 BEIGE	BN3 BEIGE		
88-469 B25E-88-470A	1	CATCH(L), RR SEAT BACK	ATTACHE(G), DOSSIER AR		
88-47YA BJ1V-88-47Y	1	LINK(L), RR SEAT BACK	BIELLE(G), DOSS. SIEGE AR		
88-607P		SPRING	RESSORT		

1701 BJ22\* -493151

(STA TYPE) (STF TYPE)  
(STB TYPE) (STG TYPE)  
(STE TYPE)

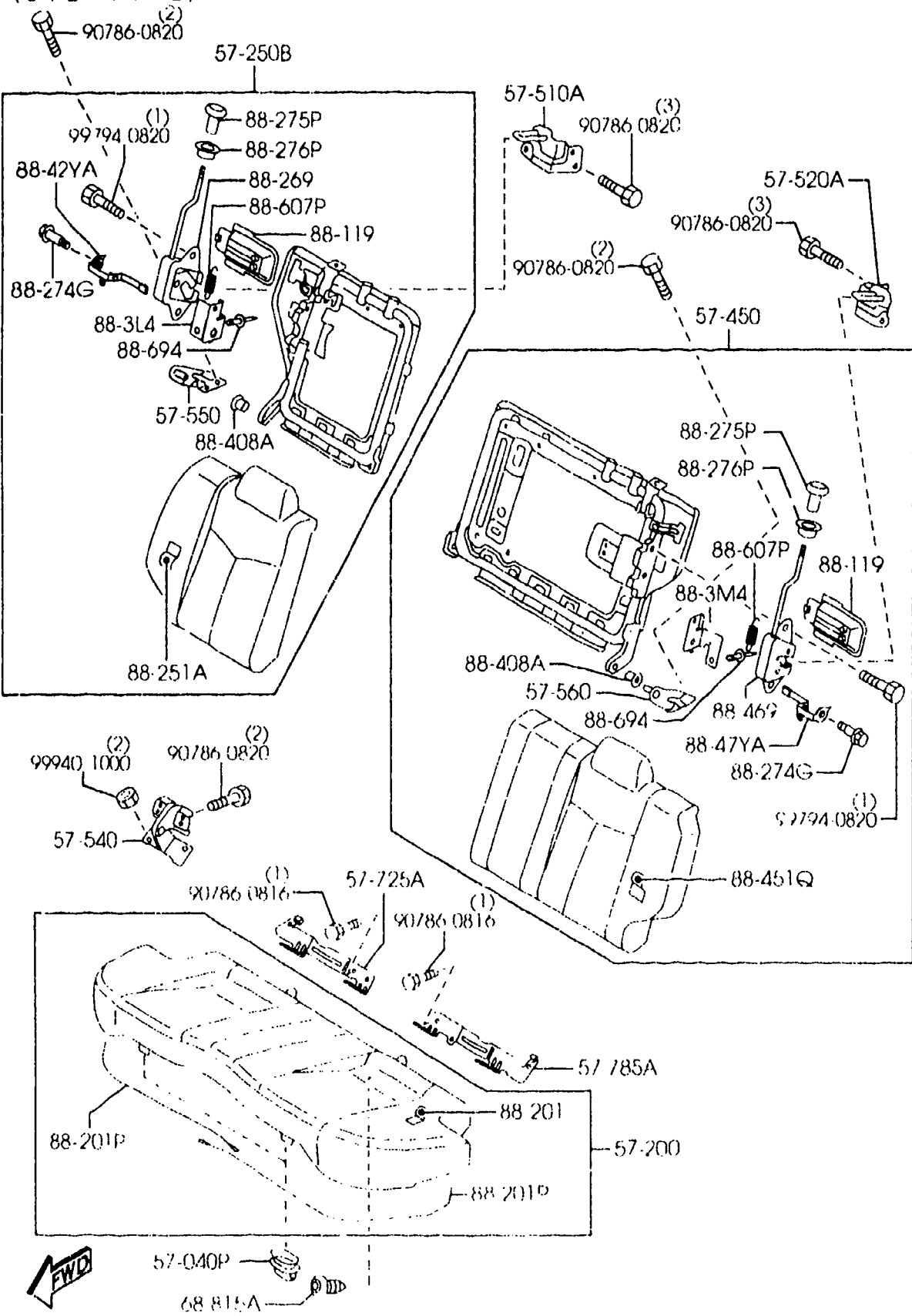

PART NO.	QTY	MODEL/RESTRICTION	MODEL/RESTRICTION	MODEL/RESTRICTION	FROM-TO
CONT'D					
BJ1V-88-015	2				
+-----+					
88-694		RIVET, BLIND	RIVET, AV. UGLE		
+-----+					
B459-88-699	4				

5750B REAR SEATS (5-DOOR)

5750B -1 REAR SEATS (5-DOOR)

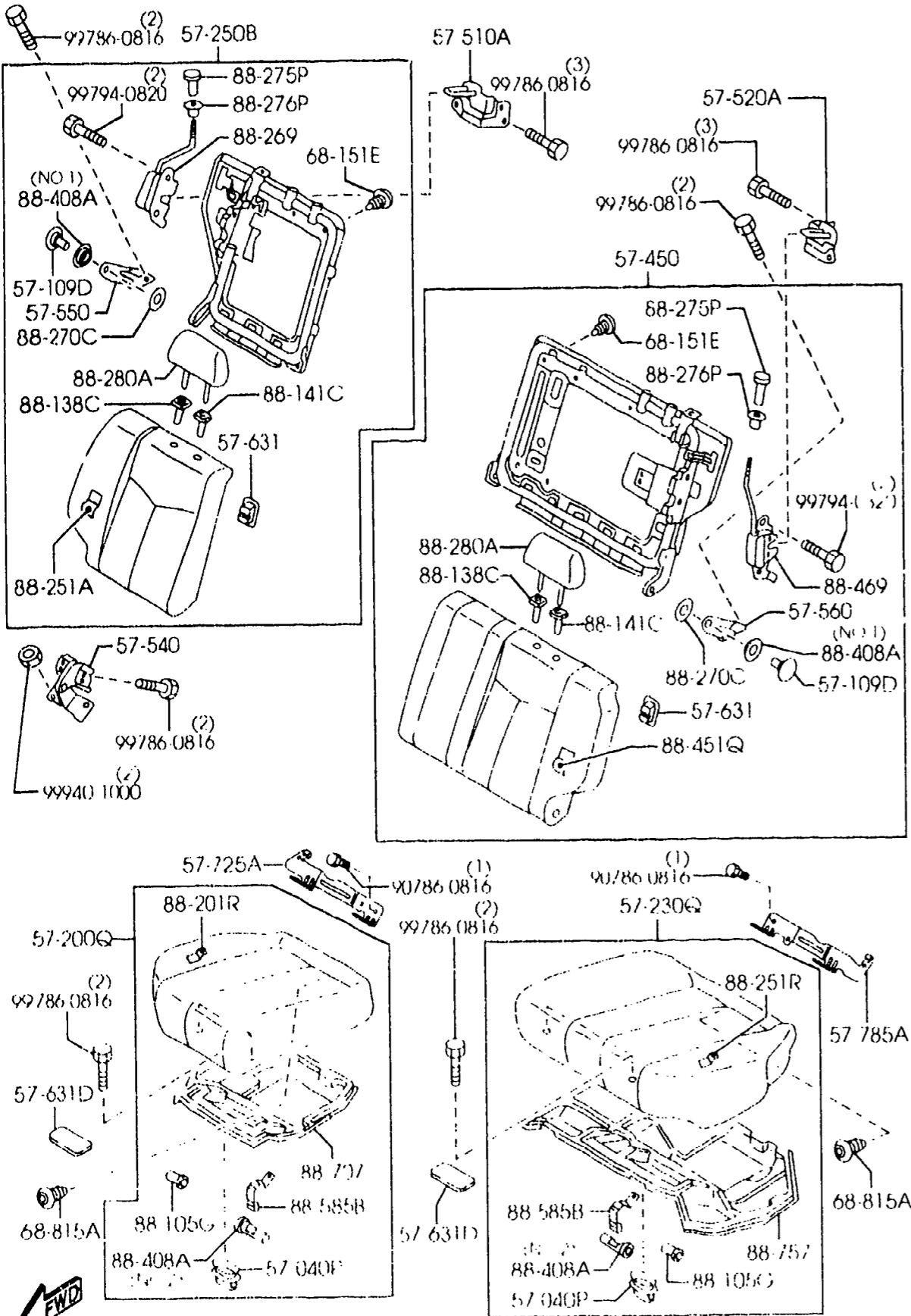

PART NO.	QTY	MODEL/RESTRICTION	MODEL/RESTRICTION	MODEL/RESTRICTION	FROM TO
57-040P		LOCK,RR. SEAT CUSHION	BLOCAGE,COUSSIN DE N		
BJ3J-88-729	3				
57-109D		SCREW,HINGE	VIS,CHARNIERE		
BC6A-88-415	2				
57-200Q		CUSHION(R),REAR SEAT	COUSSIN(D),SIEGE AR		
BL5P-57-250C	1				
65	INT-	BN4 OFF-BLACK	BN4 NOIR CLAIR		
57-230Q		CUSHION(L),REAR SEAT	COUSSIN(G),SIEGE AR		
BL5P-57-300A	1				
65	INT-	BN4 OFF-BLACK	BN4 NOIR CLAIR		
57-250B		BACK(R),REAR SEAT	SIEGE D ARR.		-1701
BN5V-57-400A	1				
65	INT-	BN4 OFF-BLACK	BN4 NOIR CLAIR		1701-
*BN5V-57-400B	1				
*65	INT-	BN4 OFF-BLACK	BN4 NOIR CLAIR		
57-450		BACK(L),REAR SEAT	SIEGE G ARR.		-1701
BN5V-57-450A	1				
65	INT-	BN4 OFF-BLACK	BN4 NOIR CLAIR		1701-
*BN5V-57-450B	1				
*65	INT-	BN4 OFF-BLACK	BN4 NOIR CLAIR		
57-510A		STRIKER(R),RR BACK	GACHE(D)		
B25E-57-510	1				
57-520A		STRIKER(L),RR BACK	GACHE(G)		
B25E-57-520	1				
57-540		HINGE,CENTER-RR BACK	CHARNIERE,CENTRE-POS SIEG		
BN5V-57-540A	1				
57-550		HINGE(R),REAR BACK	CHARNIERE(D),DOSSIER		
B30K-88-JY	1				
57-560		HINGE(L),REAR BACK	CHARNIERE(G),DOSSIER		
1701 BJ22*	-493151				

AUBA09

(2B58910)

CAT. AUBA09-02

2001-07

5750B REAR SEATS  
(5-DOOR)

5750B -2 REAR SEATS  
(5-DOOR)

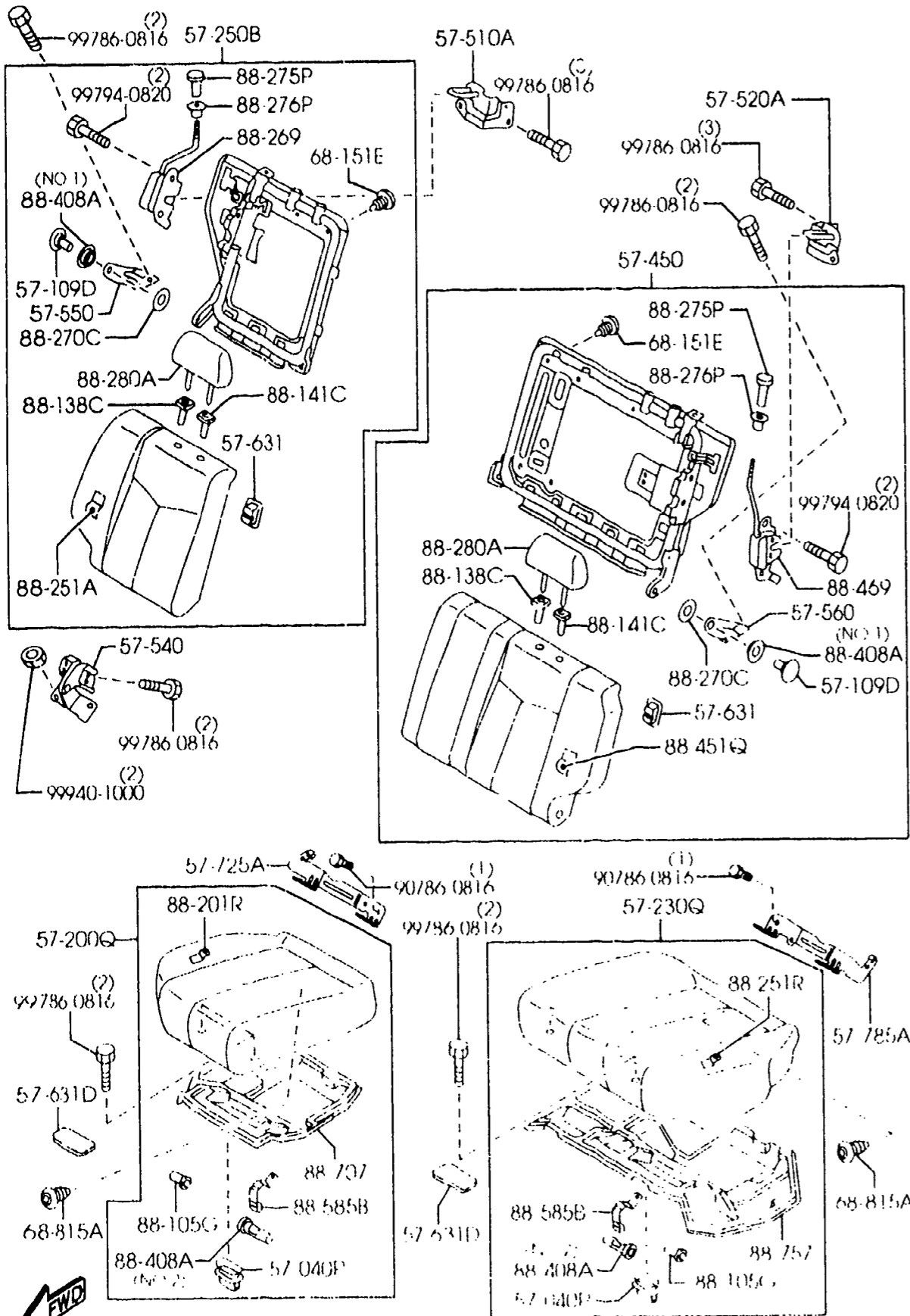

PART NO.	QTY	MODEL/RESTRICTION	MODEL/RESTRICTION	MODEL/RESTRICTION	FROM-10
CONT'D					
B30K-88-45Y	1				
57-631		COVER,ANCHOR	COUVERCLE		
B30L-88-7A6	2				
65	INT-	BN4 OFF-BLACK	BN4 NOIR CLAIR		
57-631D		COVER,HOLE-REAR SEAT	COUVERCLE,TROU-SIEGE AR.		
GK95-57-531A	2				
57-725A		ANCHOR-CHILD SEAT,LW	ANCR.SIEGE D'ENFANT INFE		
B30K-57-725D	1				
57-785A		ANCHOR-CHILD SEAT,LW	ANCR.SIEGE D'ENFANT INFE		
B30K-57-785D	1				
68-151E		CLIP	ATTACHE		
B102-68-865	8				
00	INT-	BN1 BN2 BN3 BN4 BLACK	BN1 BN2 BN3 BN4 NOIR		
68-815A		TACKER	ATTACHE		
011-68-815	2				
88-105G		BUSH,HINGE	BAGUE,CHARNICRE		
B25H-88-005	2				
88-138C		GUIDE,POLE-NO.2	GUIDE,MAT NO 2		
B25D-88-1G9A	2				
65	INT-	BN1 BN4 OFF-BLACK	BN1 BN4 NOIR CLAIR		
88-141C		GUIDE,POLE-NO.1	GUIDE,MAT NO 1		
B25D-88-1G8A	2				
65	INT-	BN1 BN4 OFF-BLACK	BN1 BN4 NOIR CLAIR		
88-201R		TRIM(R),REAR SEAT CURTAIN	GARNITURE(D),COUSSIN AR		
*BL5P-88-251B	1				
*65	INT-	BN4 OFF-BLACK	BN4 NOIR CLAIR		
88-251A		TRIM(R),RR SEAT BACK	GARNITURE,DOSSIER AR (G)		
BN5V-88-401	1				

AUBA09

(2B58910)

CAT. AUBA09-02

2001-07

5750B REAR SEATS  
(5-DOOR)

5750B -3 REAR SEATS  
(5-DOOR)

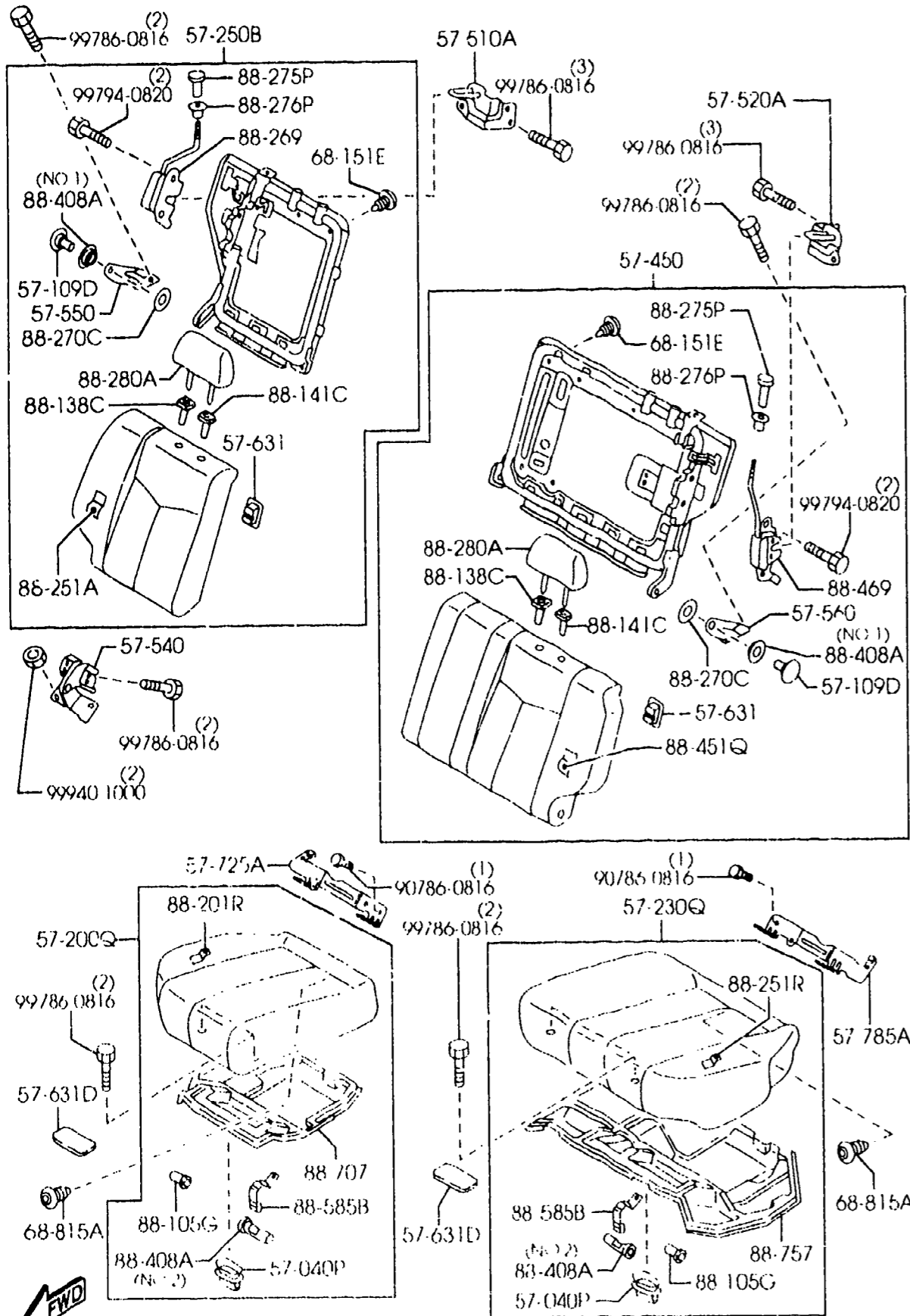

PART NO.	QTY	MODEL/RESTRICTION	MODEL/RESTRICTION	MODEL/RESTRICTION	FIG 4-10
CONT'D					
65	INT-	BN4 OFF-BLACK	BN4 NOIR CLAIR		
		88-251R	TRIM(L),REAR SEAT CUSHION	GARNITURE(G),COUSSIN AR	
BL5P-88-301	1				
65	INT-	BN4 OFF-BLACK	BN4 NOIR CLAIR		
		88-269	CATCH(R),RR SEAT BACK	ATTACHE(D),DOSSIER AR	
B25E-88-420A	1				
		88-270C	BUSH,HINGE	BAGUE,CHARNICRE	
BC6A-88-270	2				
		88-275P	KNUB,REAR SEAT BACK	BOUTON,	
B006-88-275	2				
65	INT-	BN1 BN4 OFF-BLACK	BN1 BN4 NOIR CLAIR		
		88-276P	BUSH,REAR SEAT BACK	BALAIS	
B006-88-276	2				
65	INT-	BN4 OFF-BLACK	BN4 NOIR CLAIR		
		88-280A	RESTRAINT,HEAD	REPOSE-TETE	
BL6J-88-240	2				
65	INT-	BN4 OFF-BLACK	BN4 NOIR CLAIR		
		88-451Q	BUSHING,HINGE	DOUILLE,CHARNIERE	
BC6A-88-451	2 (ILLUST. NO.1)				
B25H-88-408	2 (ILLUST. NO.2)				
		88-451Q	TRIM(L),RR SEAT BACK	HOUSSE G DOSSIER ARR	
BN5V-88-451	1				
65	INT-	BN4 OFF-BLACK	BN4 NOIR CLAIR		
		88-469	CATCH(L),RR SEAT BACK	ATTACHE(G),DOSSIER AR	
B25E-88-470A	1				
		88-585B	CLIP,WIRE	FIL,ATTACHE	
BJ3J-88-094	2				
		88-707	COVER(R)	COUVERCLE(G)	
BJ3J-88-258	1				

AUBA09

(2B58910)

CAT. AUBA09-02

2001-07



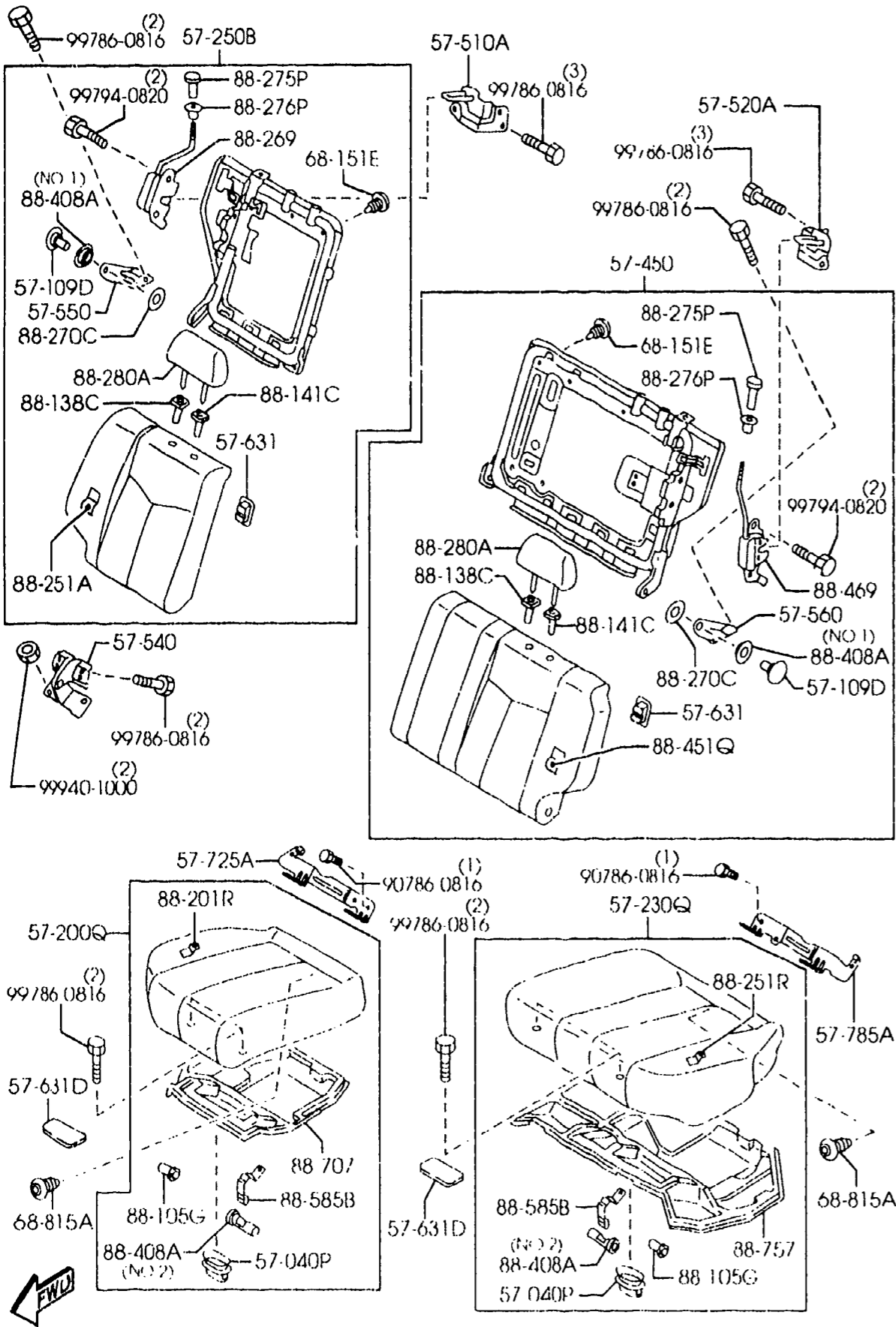

AUBA09

(2B58910)

PART NO.	QTY	MODEL/RESTRICTION	MODEL/RESTRICTION	MODEL/RESTRICTION	FROM TO
88-757		COVER(L)	CACHE		
BJ3J-88-304	1				

CA1. AUBA09-02

2001-07

5790A SEAT BELTS  
(4-DOOR)

(FRONT)

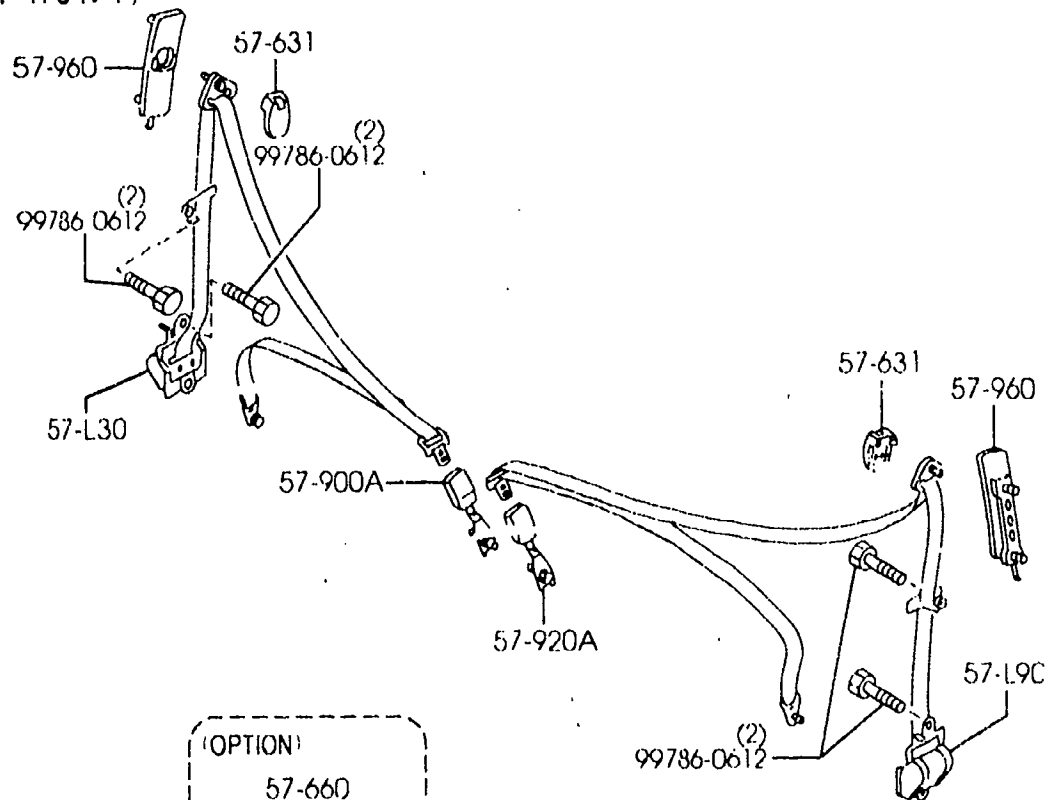

(REAR)

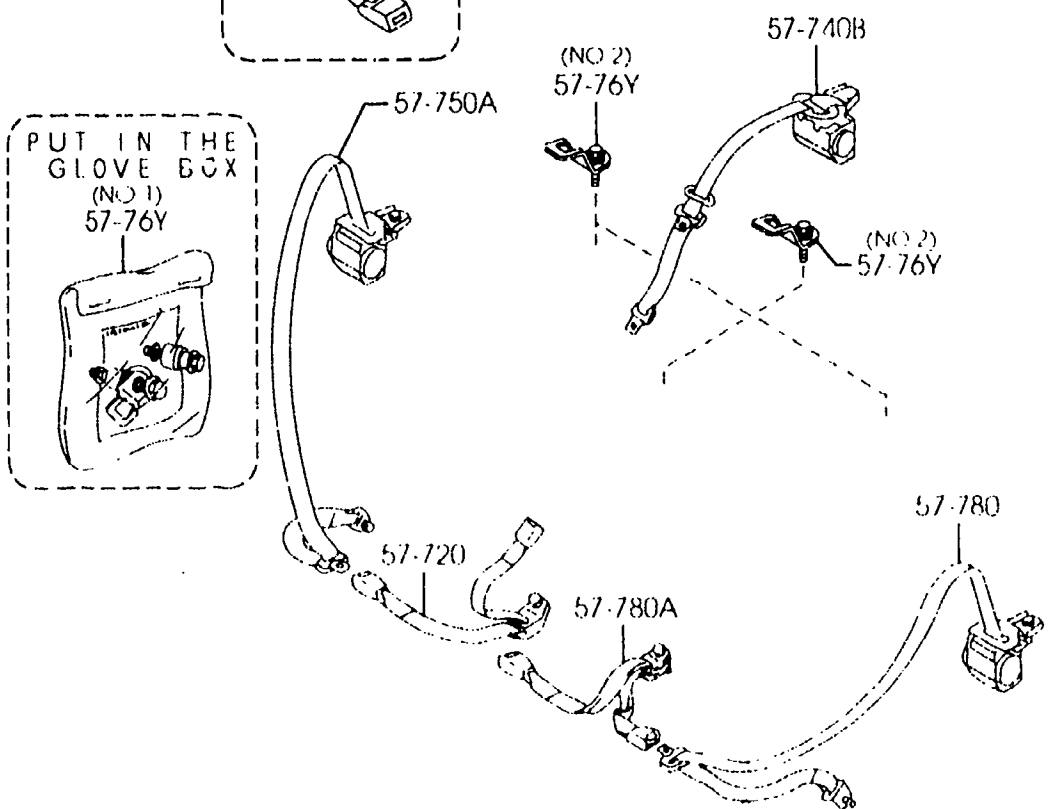

5790A -1 SEAT BELTS  
(4-DOOR)

PART NO.	QTY	MODEL/RESTRICTION	MODEL/RESTRICTION	MODEL/RESTRICTION	FROM TO
57-L30		BELT 'B' (R), PRETENSIONER	COURROIE "B" (D), PRETENSIONER		
BL8D-57-L30B	1				
03	INT-	BN4 BLACK/OFF-BLACK	BN4 NOIR/NOIR CLAIR		
05	INT-	BN1 BN2 GRAY	BN1 BN2 GRIS		
82	INT-	BN3 BROWN/BEIGE	BN3 BRUN/BEIGE		
57-L90		BELT 'B' (L), PRETENSIONER	COURROIE "B" (G), PRETENSIONER		
B30D-57-L90C	1				-1301
03	INT-	BN4 BLACK/OFF-BLACK	BN4 NOIR/NOIR CLAIR		
05	INT-	BN1 BN2 GRAY/LIGHT GRAY	BN1 BN2 GRIS/GRIS CLAIR		
82	INT-	BN3 BROWN/BEIGE	BN3 BRUN/BEIGE		
B30D-57-L90D	1				1301-
03	INT-	BN4 BLACK/OFF-BLACK	BN4 NOIR/NOIR CLAIR		
05	INT-	BN1 BN2 GRAY/LIGHT GRAY	BN1 BN2 GRIS/GRIS CLAIR		
82	INT-	BN3 BROWN/BEIGE	BN3 BRUN/BEIGE		
57-631		COVER, ANCHOR	COUVERCLE		
B25D-57-631	2				
03	INT-	BN1 BN2 BN4 LIGHT GRAY	BN1 BN2 BN4 GRIS CLAIR		
80	INT-	BN3 BEIGE	BN3 BEIGE		
57-660		BELT, EXTENSION-FRONT SEAT	CEINTURE, EXTENT-SIEGE AV		
BJYE-57-63X	1	12 INCH (OPTION)	12 INCH		
BJYF-57-63X	1	9 INCH (OPTION)	9 INCH		
57-720		BELT 'A' (R), REAR SEAT	CEINTURE 'A' (D), SIEGE AR		
B30D-57-720	1				
05	INT-	BN1 BN2 GRAY/LIGHT GRAY	BN1 BN2 GRIS/GRIS CLAIR		
66	INT-	BN4 BLACK	BN4 NOIR		
82	INT-	BN3 BROWN/BEIGE	BN3 BRUN/BEIGE		
57-740B		BELT (C), RR SEAT	CEINTURE (C), SIEGE AR		
BL8D-57-740A	1				
04	INT-	BN4 BLACK	BN4 NOIR		
1301 BJ22* -440775					

5790A SEAT BELTS  
(4-DOOR)

(FRONT)

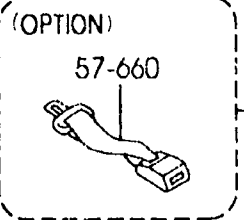
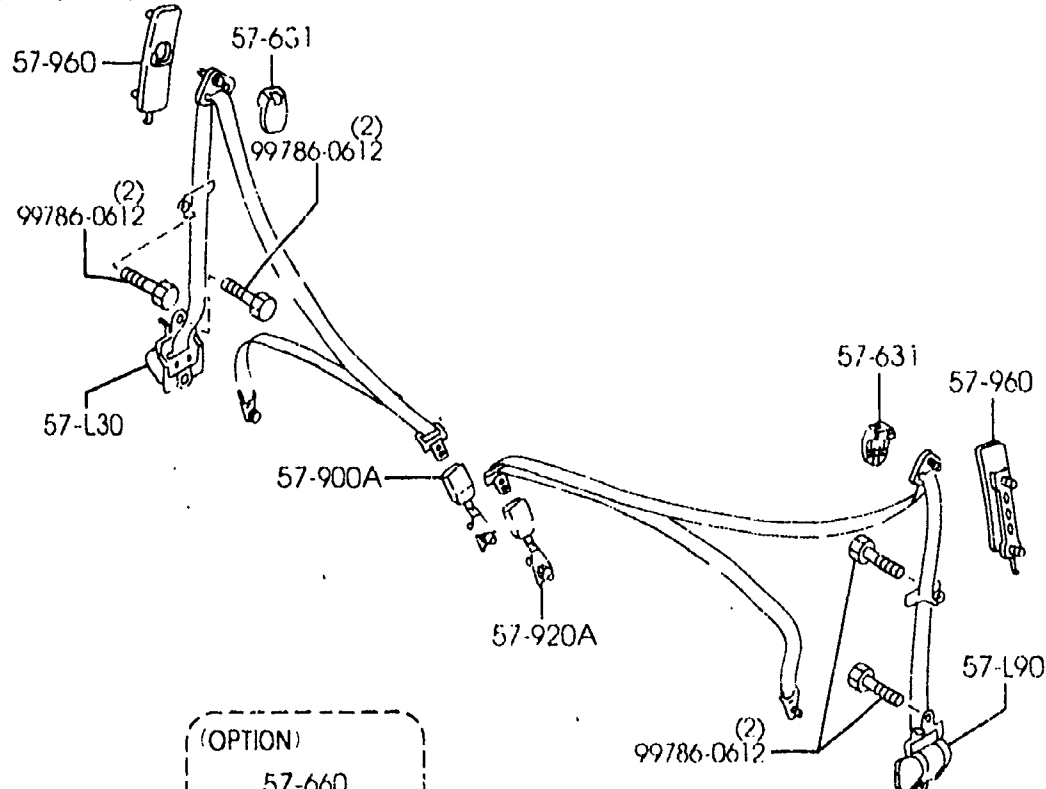

(REAR)

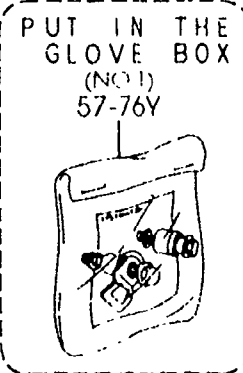
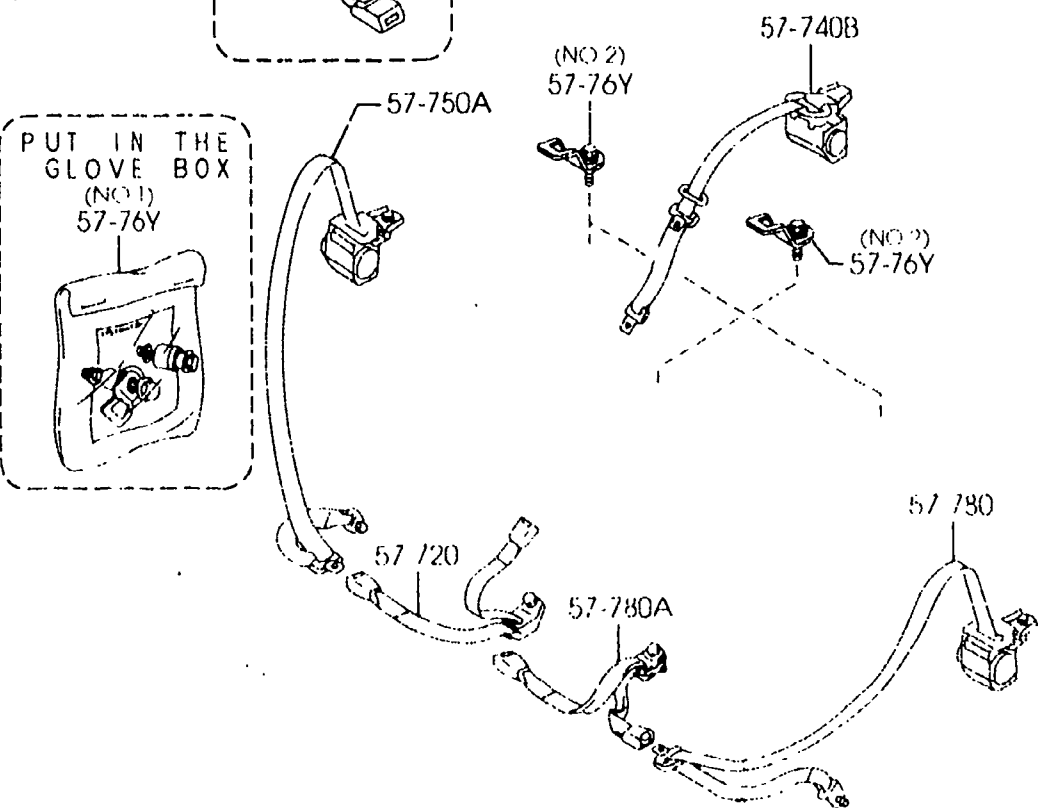

AUBA09

(2B47740)

5790A -2 SEAT BELTS  
(4-DOOR)

PART NO.	QTY	MODEL/RESTRICTION	MODEL/RESTRICTION	MODEL/RESTRICTION	FROM-TO
CONT'D					
05	INT-	BN1 BN2 GRAY	BN1 BN2 GRIS		
82	INT-	BN3 BROWN/BEIGE	BN3 BRUN/BEIGE		
		+-----+			
		57-750A	BELT 'B'(R), REAR SEAT	CEINTURE 'B'(D), SIEGE	
		+-----+		ARR.	
B30D-57-730	1				
05	INT-	BN1 BN2 GRAY/LIGHT GRAY	BN1 BN2 GRIS/GRIS CLAIR		
66	INT-	BN4 BLACK	BN4 NOIR		
82	INT-	BN3 BROWN/BEIGE	BN3 BRUN/BEIGE		
		+-----+			
		57-76Y	ANCHOR, BELT-CHILD SE	FIXATION, CEINTRE-SIE	
		+-----+	AT	G ENF	
BJOE-57-77XA	1	(ILLUST. NO.1)			
		(OPTION)			
BL8D-57-77ZA	3	(ILLUST. NO.2)			-1801
		(STD.)			
*BL8D-57-77ZB	3	(ILLUST. NO.2)			1801-
		(STD.)			
		+-----+			
		57-780	BELT 'B'(L), REAR SEAT	CEINTURE 'B'(G), SIEGE	
		+-----+		ARR.	
B30D-57-790	1				
05	INT-	BN1 BN2 GRAY/LIGHT GRAY	BN1 BN2 GRIS/GRIS CLAIR		
66	INT-	BN4 BLACK	BN4 NOIR		
82	INT-	BN3 BROWN/BEIGE	BN3 BRUN/BEIGE		
		+-----+			
		57-780A	BELT 'A'(L), REAR SEAT	CEINTURE 'A'(G), SIEGE	
		+-----+		AR	
BL2A-57-780	1				
05	INT-	BN1 BN2 GRAY/LIGHT GRAY	BN1 BN2 GRIS/GRIS CLAIR		
66	INT-	BN4 BLACK	BN4 NOIR		
82	INT-	BN3 BROWN/BEIGE	BN3 BRUN/BEIGE		
		+-----+			
		57-900A	BELT 'A'(R), FRT SEAT	CEINTURE "A"(D)AV.	
		+-----+			
B25D-57-680	1				
05	INT-	BN1 BN2 GRAY/LIGHT GRAY	BN1 BN2 GRIS/GRIS CLAIR		
66	INT-	BN4 BLACK	BN4 NOIR		
82	INT-	BN3 BROWN/BEIGE	BN3 BRUN/BEIGE		
		+-----+			
		57-920A	BELT 'A'(L), FRT SEAT	CEINTURE "A"(G)AV.	
		+-----+			

CAT. AUBA09-02

2001-07

5790A SEAT BELTS  
(4-DOOR)

5790A -3 \* SEAT BELTS  
(4-DOOR)

(FRONT)

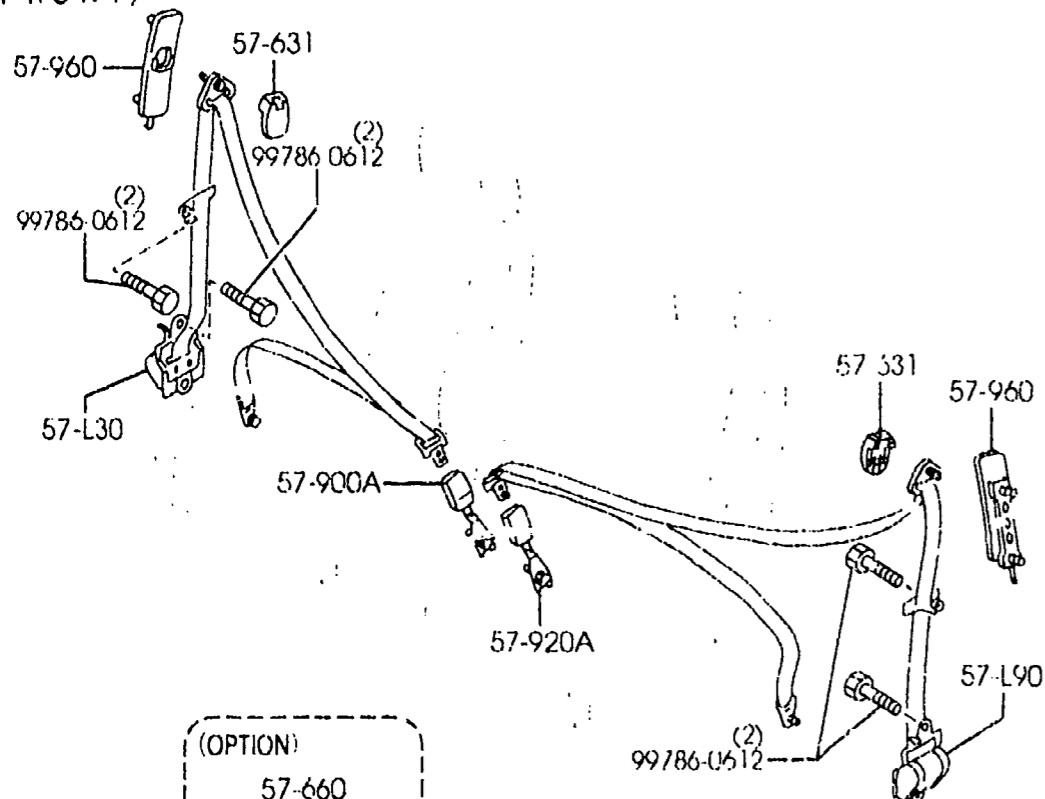

(REAR)

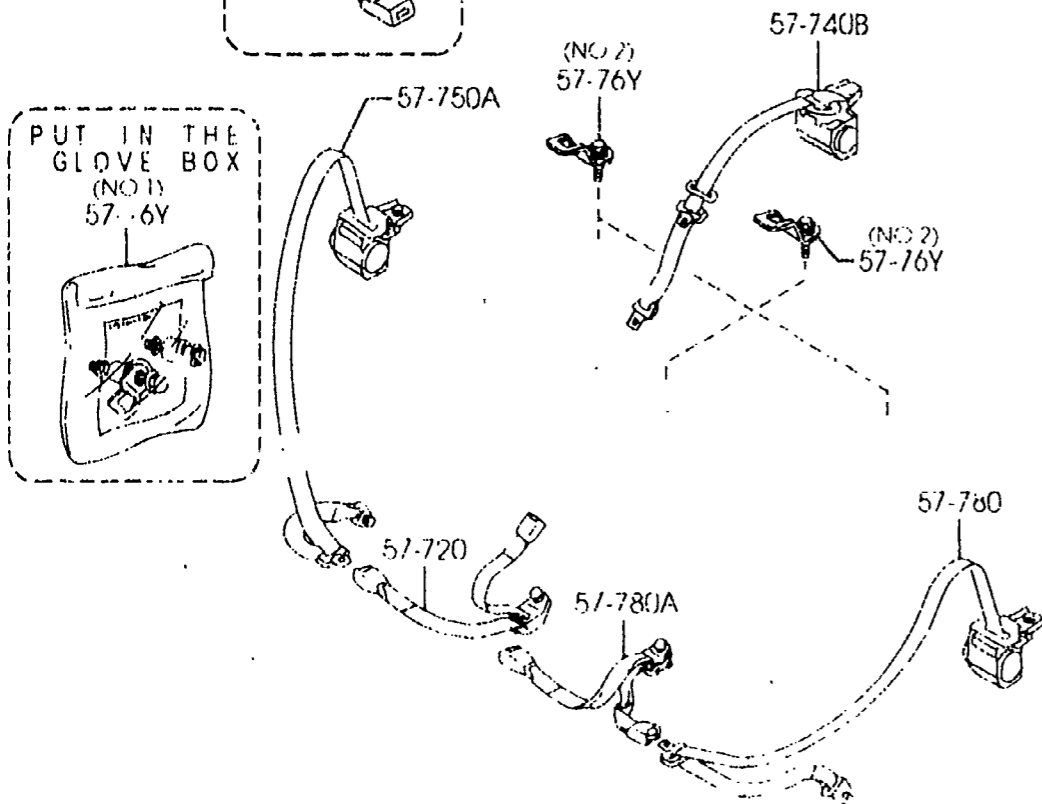

PART NO.	QTY	MODEL/RESTRICTION	MODEL/RESTRICTION	MODEL/RESTRICTION	FROM-TO
CONT'D B25D-57-620B	1				
05	INT-	BN1 BN2 GRAY/LIGHT GRAY	BN1 BN2 GRIS/GRIS CLAIR		
66	INT-	BN4 BLACK	BN4 NOIR		
82	INT-	BN3 BROWN/BEIGE	BN3 BRUN/BEIGE		
		-----+			
		57-960			
		-----+			
B25D-57-960C	2				
05	INT-	BN1 BN2 BN4 LIGHT GRAY	BN1 BN2 BN4 GRIS CLAIR		
80	INT-	BN3 BEIGE	BN3 BEIGE		

AUBA09

(2B47740)

CAT. AUBA09-02

2061-07

(FRONT)

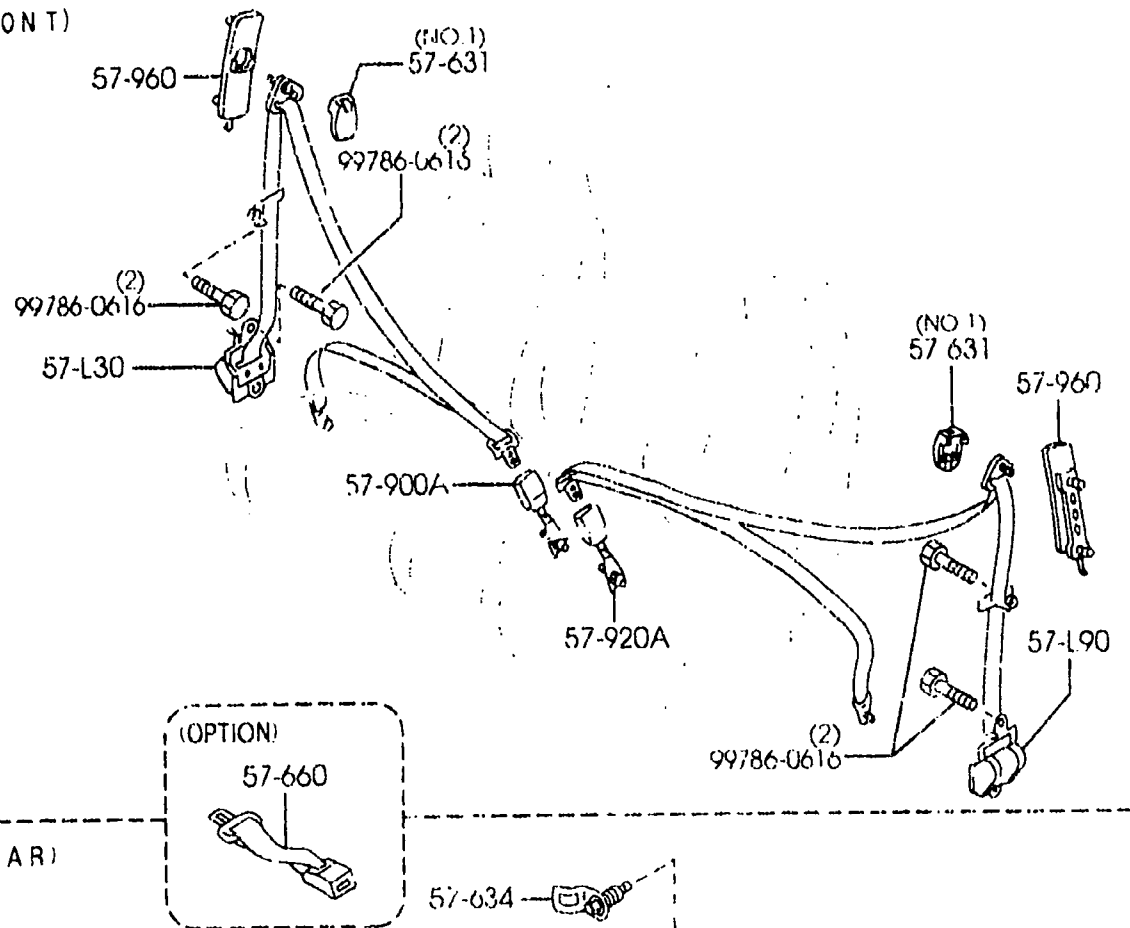

(REAR)

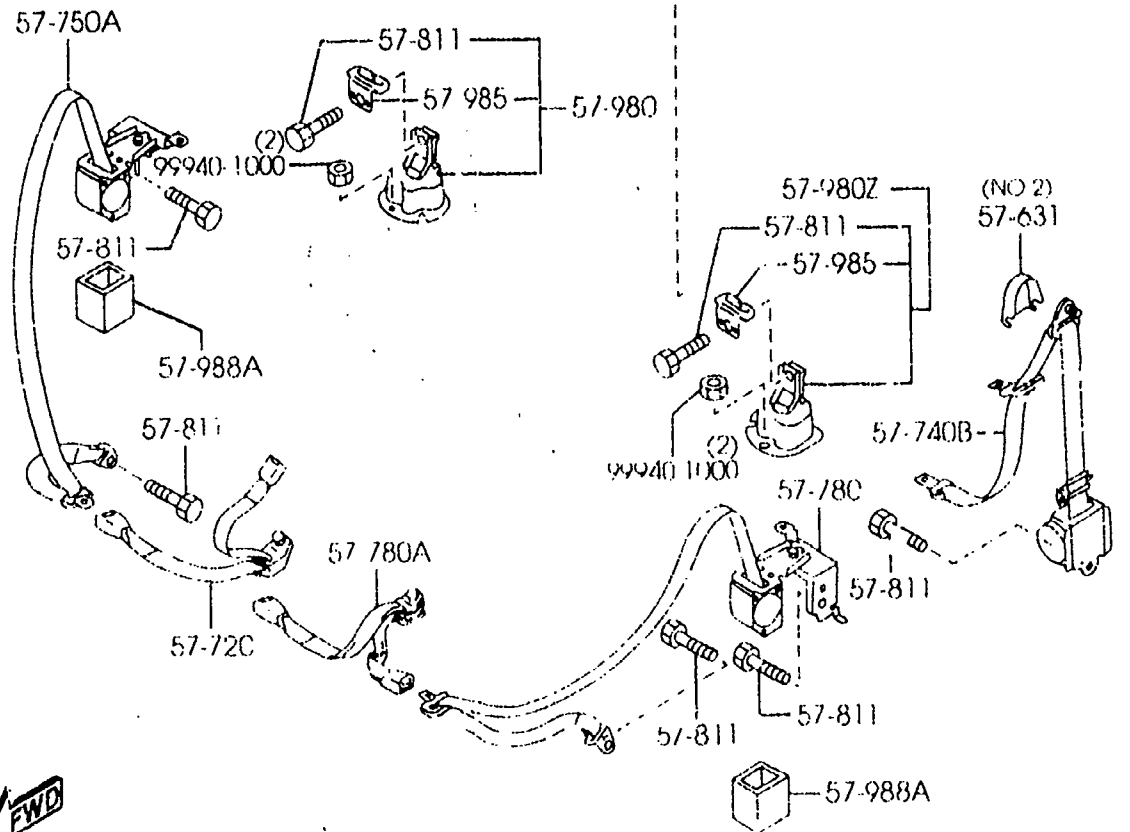

PART NO	QTY	MODEL/RESTRICTION	MODEL/RESTRICTION	MODEL/RESTRICTION	FROM-TO
57-L30		BELT 'B' (R), PRETENSIONER	COURROIE "B" (D), PRETENSIONIO.		
BL8D-57-L30B	1				
03	INT-	BN4 BLACK/OFF-BLACK	BN4 NOIR/NOIR CLAIR		
57-L90		BELT 'B' (L), PRETENSIONER	COURROIE "B" (G), PRETENSIONIO.		
B30D-57-L90D	1				
03	INT-	BN4 BLACK/OFF-BLACK	BN4 NOIR/NOIR CLAIR		
57-631		COVER, ANCHOR	COUVERCLE		
B25D-57-631	2	(ILLUST. NO.1)			
03	INT-	BN1 BN2 BN4 LIGHT GRAY	BN1 BN2 BN4 GRIS CLAIR		
H260-57-631	1	(ILLUST. NO.2)			
03	INT-	BN1 BN2 BN4 LIGHT GRAY	BN1 BN2 BN4 GRIS CLAIR		
57-634		ANCHOR, SEAT BELT	ANCRE, CEINTURE SECURITE		
BN5V-57-72ZA	1				
57-660		BELT, EXTENSION-FRONT SEAT	CEINTURE, EXTENT-SIEGE AV		
BJYE-57-63X	1	12 INCH (OPTION)	12 INCH		
BJYF-57-63X	1	9 INCH (OPTION)	9 INCH		
57-720		BELT 'A' (R), REAR SEAT	CEINTURE 'A' (D), SIEGE AR		
BN5V-57-720	1				
66	INT-	BN4 BLACK	BN4 NOIR		
57-740B		BELT (C), RR SEAT	CEINTURE (C), SIEGE AR		
BN5V-57-740	1				
66	INT-	BN4 BLACK	BN4 NOIR		
57-750A		BELT 'B' (R), REAR SEAT	CEINTURE 'B' (D), SIEGE ARR.		
B25H-57-730E	1				
66	INT-	BN4 BLACK	BN4 NOIR		
57-780		BELT 'B' (L), REAR SEAT	CEINTURE 'B' (G), SIEGE ARR.		
B2EH-57-790E	1				
66	INT-	BN4 BLACK	BN4 NOIR		

5790B SEAT BELTS  
(5-DOOR)

57903 -2 \* SEAT BELTS  
(5-DOOR)

(FRONT)

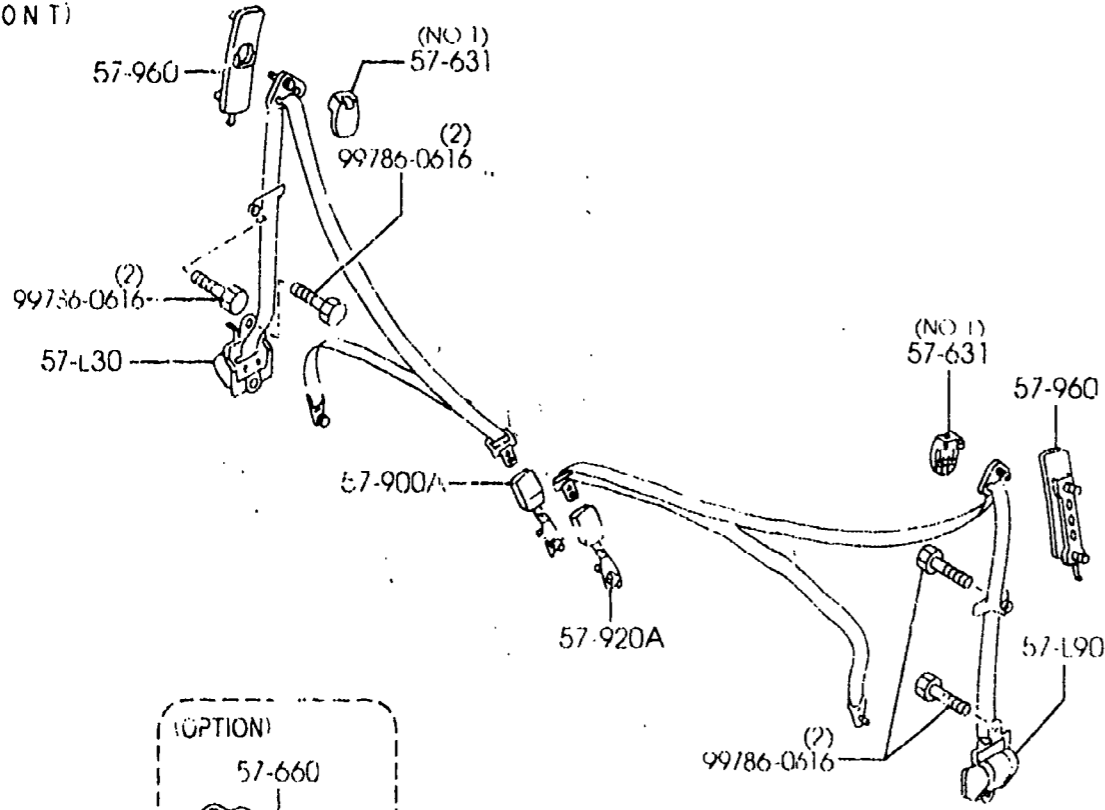

(REAR)

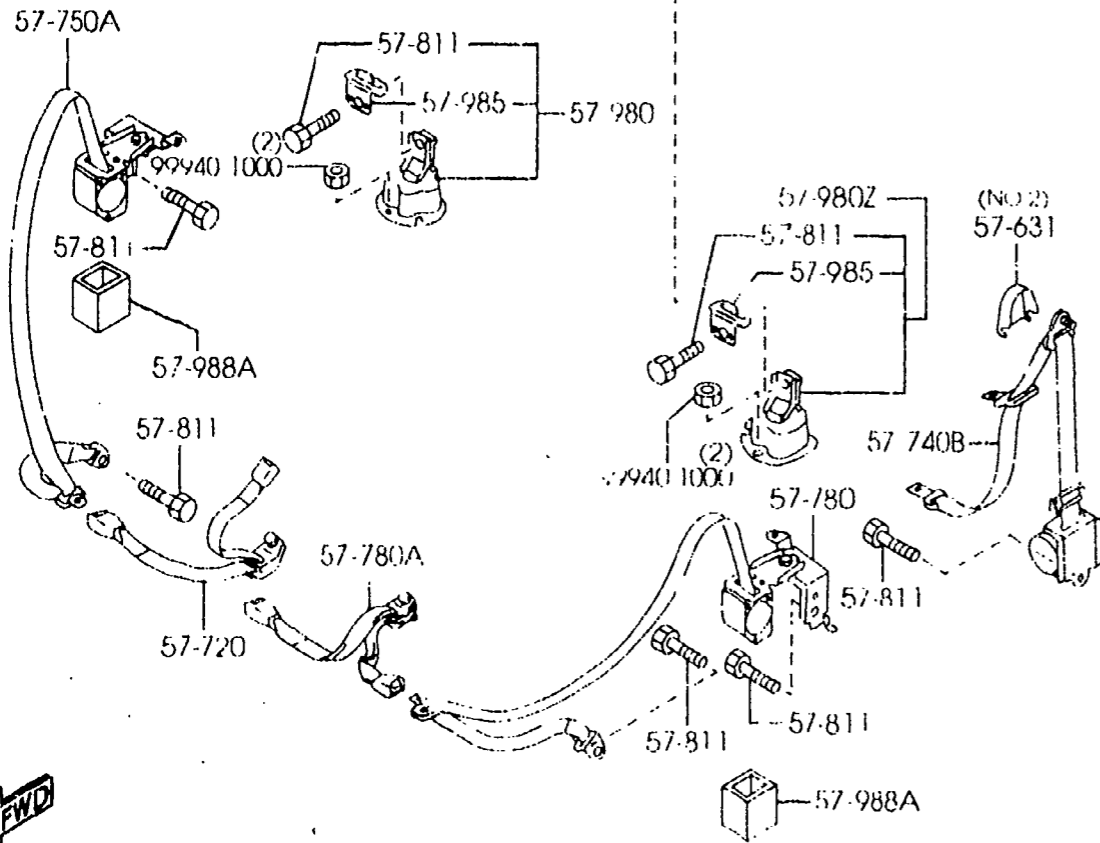

PART NO.	QTY	MODEL/RESTRICTION	MODEL/RESTRICTION	MODEL/RESTRICTION	FROM - TO
57-780A		BELT 'A' (L), REAR SEAT	CEINTURE 'A' (G), SIEGE AR		
BN5V-57-780	1				
66	INT-	BN4 BLACK	BN4 NOIR		
57-811		BOLT, SEAT BELT	BOULON		
M001-57-811	7				
57-900A		BELT 'A' (R), FRT SEAT	CEINTURE "A" (D) AV.		
B250-57-680	1				
66	INT-	BN4 BLACK	BN4 NOIR		
57-920A		BELT 'A' (L), FRT SEAT	CEINTURE "A" (G) AV.		
B250-57-620B	1				
66	INT-	BN4 BLACK	BN4 NOIR		
57-960		ADJUSTER, SHOULDER	REGULATEUR, EPAULEMENT		
B250-57-960C	2				
03	INT-	BN1 BN2 BN4 LIGHT GRAY	BN1 BN2 BN4 GRIS CLAIR		
57-980		BRACKET (R), RETRACTOR	SUPPORT (D)		
B25H-57-92XE	1				
57-980Z		BRACKET (L), RETRACTOR	SUPPORT (L)		
B25H-57-99XE	1				
57-985		PLATE SET, SEAT BELT	PLAQUE DE FIX.,		
B25H-57-985B	2				
57-988A		SCREWN, RETRACTOR	ECRAN, RETRACTEUR		
GG3E-57-988	2				

AUBA09

(2E-58850)

CAT. AUBA09 02

2001-07

3-N16